



CAVALON

Manufacturer Maintenance Manual

(Heavy Maintenance)



**Manufacturer Maintenance Manual
for Gyroplane Cavalon**

0 – PREFACE

This document contains proprietary information of AutoGyro GmbH, Germany which is provided in confidence and solely for the purpose of supporting aircraft certification and providing applicable information regarding the proper use, maintenance, inspection, repair, servicing and parts application of AutoGyro GmbH products and services, as directed therein. Neither this manual nor any information in it may be disclosed to others, or used for any other purpose, including but not limited to, design, create, develop, reproduce, manufacture or derive any design, part, product, material, process, modification, configuration change or repair, or to obtain airworthiness authorisation's approval to do so.

With the possession and use of this manual the user accepts and agrees to bound by the foregoing terms.

If a Government agency or Department intends to disclose any information, written notice should be given to:

AutoGyro GmbH
Dornierstraße 14
31137 Hildesheim
GERMANY

Phone: +49 (0) 51 21 / 8 80 56-00

Fax: +49 (0) 51 21 / 8 80 56-19

E-Mail: info@auto-gyro.com

All rights reserved. Under the copyright laws, this manual may not be copied, in whole or in part, without the written consent of AutoGyro GmbH. AutoGyro reserves the right to change or improve its products and to make changes in the content of this manual without obligation to notify any person or organisation of such changes or improvements. Notifications to the Civil Aviation Authorities or other organisations based on legal regulations are unaffected.

MTOsport, Calidus, Cavalon, the AutoGyro logo and word picture mark are trademarks or registered trademarks of AutoGyro AG, registered in Germany and other countries.

Other company and product names mentioned herein may be trademarks of their respective companies. Mention of third-party products is for informational purposes only and constitutes neither an endorsement nor a recommendation. AutoGyro assumes no responsibility with regard to the performance or use of these products. All understandings, agreements, or warranties, if any, take place directly between the vendors and the prospective users.

U.S. and foreign patents of AutoGyro AG are used in the Calidus and Cavalon gyroplanes - (US.Pat.No. 8,690,100; US.Pat.No. D699,153)

Every effort has been made to ensure that the information in this manual is accurate. AutoGyro GmbH is not responsible for printing or clerical errors.

1 – INTRODUCTION

This manual provides accepted and recommended maintenance procedures applicable for the Cavalon gyroplane, designed and manufactured by AutoGyro GmbH, Hildesheim, Germany. The generic term “maintenance” comprises checks, inspections, replacement, repair and other tasks, which are defined in “01-11-00 Definitions and Standard Procedures”. The manual also provides a full description of the aircraft and its systems and troubleshooting (fault isolation) procedures. Where applicable, the manual refers to related manuals, such as the engine manufacturer’s documentation or Component Maintenance Manuals, for example battery, avionics, or optional equipment.

All task descriptions follow aerospace, industry and safety standards or special AutoGyro procedures. The procedures, methods, instructions and parameters specified in this manual must be adhered to by all means. It is not permitted to change procedures or to alter parameters provided herein. Proposed deviations from the procedures, methods and instructions contained in this manual should be directed to:

AutoGyro GmbH
Att.: Technical Publications
Dornierstraße 14
31137 Hildesheim
GERMANY

Fax: +49 (0) 51 21 / 8 80 56-19
E-Mail: info@auto-gyro.com

The manual has been prepared in accordance with ATA Specification No. 100 being a common standard in aviation and for your convenience. The ATA100 numbering system is described under “Organization and Handling of the Manual”.

This manual will be revised as necessary to incorporate changes in design, parts, approved procedures, or parameters. Note that the manual is only valid if available in current version. The use of an out dated manual may render the aircraft in unsafe or even not airworthy condition. The revision service is described below.

Manufacturer Information [Letters] (MI) or Airworthiness Directives (AD) will also be covered by the revision service and incorporated in the maintenance manual.

Revision Service

This manual must always be maintained in current, up-to-date status. The latest version status is available at www.auto-gyro.com. Note that the manual is subdivided into 6 parts which will be revised individually. As an example, the revision index for the manufacturer maintenance manual (MMM), Cavalon (CV), Part B could be ‘MMM-CV-B_13-04-20’. Note that the date code is ‘yy-mm-dd’ so files will sort chronologically.

For the purpose of current status this manual will not be published in paper format. A current personalized copy will be provided by AutoGyro GmbH for all certified and registered service partners on the basis of a subscription service. Registered users will be informed about new revisions. We recommend **not** to keep printouts or paper copies for reference.

Record of Revisions

The manufacturer will keep this manual current as an entire document. After each revision of a part the latest revision index (i.e. list of revision indices for each part) will be published on AutoGyro’s web portal and/or by E-Mail to each subscription customer. The document part’s revision index can be found in the footer on the left hand side of each page.

INTENTIONALLY LEFT BLANK

Contents

0 – PREFACE.....	2
1 – INTRODUCTION	3
Revision Service.....	3
Record of Revisions	3
Maintenance Concept and Eligibility	7
Warnings, Caution and Notes	7
Organization and Handling of the Manual	8
ATA100 Numbering System	8
ATA100 – Chapter Code	8
Nomenclature and Structure of Maintenance Tasks (Job Cards)	9
Page Block Code.....	9
Effectivities.....	10
Parts List Codes – PC / PIT.....	10
Abbreviations and Acronyms.....	11
Service Bulletin (SB) and Airworthiness Directives (AD)	12

INTENTIONALLY LEFT BLANK

Maintenance Concept and Eligibility

The maintenance concept of the Cavalon gyroplane is structured into 4 qualification levels:

- Basic operational (OPR) Maintenance / Pilot Checks and Servicing
- Line (LNE) Maintenance (inspection of Critical Parts (CP) included)
- Heavy (HVY) Maintenance (Flight Safety Sensitive Maintenance Tasks, handling of CPs)
- Specialized (SPC) Level Tasks (Major Modification, Repair & Overhaul, Special Topics)

The respective maintenance level for each maintenance task is printed in right hand position in the header line on each Job Card as three-letter code for quick reference (see red circle in example below) and repeated under ‘GENERAL, REFERENCES AND REQUIREMENTS’.



63-51-00 8-1 REPLACEMENT: ROTOR BRAKE PAD

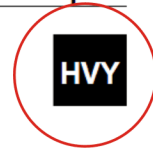

Maintenance tasks may be carried out solely by persons or organizations fulfilling the requirements for personal qualification, infrastructure and required equipment, and only in strict compliance with the documentation and manuals listed in below table. Examples are provided for better illustration:

Level	Qualification	Documentation	Example
OPR	Licensed Pilot or trained/briefed person	Pilot’s Operating Handbook and Job Cards marked ‘OPR’	Check and replenish engine coolant.
LNE	AutoGyro maint. course (and organization approval) ‘Line’	Manufacturer Maint. Manual (MMM) Job Cards ‘LNE’	All tasks to perform a 100 hrs inspection
HVY	AutoGyro maint. course and organization approval ‘Heavy’	Manufacturer Maint. Manual (MMM) Job Cards ‘HVY’	Adj. / replace rotor head, flight controls
SPC	AutoGyro special courses and org. approval ‘Specialized’	MMM Job Cards ‘SPC’ and manufacturer instructions	Main frame overhaul, major mod., repair

Warnings, Caution and Notes

This manual uses **WARNINGS**, **CAUTIONS** and **NOTES** in bold italic letters to indicate especially critical and important instructions. The call-outs appear at the top of the Maintenance Job Card if of general nature or applicable for the complete task, or will directly precede the individual Work Step.

The meaning of each call-out is defined below:

WARNING: A warning means that the neglect of the appropriate procedure or condition could result in personal injury or fatal accidents.

CAUTION: A caution means that the neglect of the appropriate procedure or condition could result in damage to or destruction of equipment.

NOTE: A note stresses the attention for a special circumstance, which is essential to emphasize.

Organization and Handling of the Manual

This manual is structured according to ATA100 numbering system. The numbering system will be explained later in more detail.

On document level, the manual is subdivided into 6 parts, named A to F. The designation and content of each part is listed below:

Part	Designation / Content
A	Introduction and Declarations This section. Explains the basic concept, handling of this manual, its structure according to the ATA100 numbering system, abbreviations and acronyms.
B	Master Servicing Manual (ATA Chapters 00 to 20) General description of the aircraft, basic definitions and standard procedures, tools, spares, airworthiness limitations, time limits, inspections and checks. Briefly, part B describes 'what is to be done, and when'.
C	System Description Section (ATA Chapters 21 to 90) Part C describes all aircraft systems, following the ATA100 numbering system.
D	Diagrams and Charts Part D contains diagrams and charts, if necessary in special sizes or as fold-outs.
E	Maintenance Job Cards [Maintenance] Job Cards are collected in Part E. Note that the footer of Part E does not spell out to the part's designation, but just shows part and the job index of the referred maintenance task according to the ATA100 numbering system. Briefly, Part E describes 'how something has to be done'.
(F)	Protocols and Forms Protocols and forms, such as maintenance check lists, are available for download.

ATA100 Numbering System

ATA100 – Chapter Code

The Air Transport Association (ATA) Standard 100 numbering system is a widely accepted standard that provides a 6 digit numbering system to identify aircraft systems, subsystems and individual components in a structured, hierarchical approach.

The first or leftmost pair of digits defines the Chapter, respectively system. The next pair of digits refers to the subsystem. The third pair of digits specifies a unit. Only complex systems use unit numbers. In case of simple systems, all information is contained in the main chapter and there is no subsystem or unit breakdown.

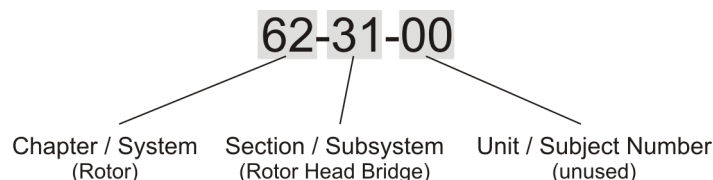

The ATA100 numbering system and the corresponding system designations were adopted where ever possible and rational. In some cases the wording and nomenclature was adapted to match the design specifics of a gyroplane in best possible way. Due to its high degree of system integration, some systems cannot clearly be assigned to a single function. In this case the system or component was categorized by its main function. Example: the pneumatic trim cylinder also acts as brake in its secondary function.

Chapter 02 has been modified to contain "TOOLS, SPARES AND CONSUMABLE MATERIALS".

Nomenclature and Structure of Maintenance Tasks (Job Cards)

Part E of this manual describes maintenance tasks to be performed by a qualified person in order to check, inspect, replenish, adjust, replace, repair, clean, or to identify malfunctions. Each **Task** is outlined in detail in a **[Maintenance] Job Card**.

Each **[Maintenance] Job Card** (sometimes referred to as Task Card) consists of

- **Task Description** (header, descriptive text) with task level in most right position
- a section referring to GENERAL, REFERENCES AND REQUIREMENTS
- a section listing SPECIAL TOOLS AND CONSUMABLE MATERIALS
- a section pointing out PRECAUTIONS AND SAFETY MEASURES
- a section called PROCEDURES, which lists all **Work Steps** to be performed subsequently
- a PARTS LIST listing part numbers and associated information, and
- explanatory GRAPHICS, such as explosion drawings or photographs

For ease of navigation each page in Part E shows a unique job index in the page footer consisting of 3 elements:

- **Chapter Code**
(acc. to ATA100, see explanation below)
- **Page Block Code**
(distinct index/number per type of maintenance action, see explanation below)
- **Sub-Index**



Page Block Code

The pages within a chapter are structured and numbered according to the page block numbering system as specified below:

Subject	Code
Introduction / Description and Operation	0
Fault Isolation / Trouble Shooting	1
Maintenance Procedures	2
Servicing	3
Removal / Installation / Disassembly / Assembly	4
Adjustment / Test	5
Inspection	6
Cleaning / Painting	7
Repair / Replacement / Retrofit / Modification	8
Storage	9

Effectivities

A job card may contain information relating to different versions of the referred aircraft. This may be stipulated by optional equipment installed, by different design states (Serial Number driven), or modification (MI, AD).

The keyword **EFFECTIVITY**, followed by a term describing its applicability, marks the start of instructions that apply exclusively to a specified version. Examples:

EFFECTIVITY: Variable Pitch Propeller

The following instructions must be performed and are applicable only if a Variable Pitch Propeller is installed

EFFECTIVITY: up to S/N 0123

The following instructions apply to serial numbers 0123 and before

EFFECTIVITY: S/N 0124 to S/N 0248

The following instructions refer only to serial numbers 0124 up to, and including, 0248

EFFECTIVITY: S/N 0124 and subsequent

The following instructions must be performed for serial numbers starting 0124 and subsequent

EFFECTIVITY: before MI 2011-99

Instructions refer to modification state before/without the referenced MI implemented

EFFECTIVITY: MI 2011-99 accomplished

Instructions apply only to those versions where the referenced MI has been accomplished

The end of the range of validity is marked by the term **EFFECTIVITY – END**

In case the effectivity solely comprises of the subsequent work step, or another effectivity statement is introduced, the term **EFFECTIVITY – END** will be omitted.

Instructions outside of **EFFECTIVITY** statements apply to the standard model, respectively to all versions.

Parts List Codes – PC / PIT

Parts Lists specify PC (Procurement Code) and PIT (procure item through) for each item (see example). The procurement code may show L0, L1, L2 or L3 as explained below.

L0	Part/Assembly available for purchase for a registered pilot/operator (OPR)
L1	Part/Assembly orderable for individuals/organizations qualified to perform Line Maint.
L2	Part/Assembly orderable for organizations qualified to perform Heavy Maintenance
L3	Part/Assembly orderable for organizations qualified to perform Specialized Level tasks

‘PIT’ lists the order number of the part, bundle, set, or smallest assembly in which the referred part is contained.

PARTS LIST			PC	PIT	Remark
Fig.	Pos.	Description			
1	1-2	Replacement kit rotorhub I bolts	L1	62-00-00-S-33356	(RSI)
1	1-2	Replacement kit rotorhub II bolts	L1	62-00-00-S-33355	

Abbreviations and Acronyms

In this manual, a minimum number of abbreviations are used. Where possible the abbreviations and acronyms used correspond with regulations and common standards.

AD	Airworthiness Directive
ATA	Air Transport Association
CHT	Cylinder Head Temperature
CP	Critical Part
CRP	Carbon Reinforced Plastic
DOM	Date of Manufacture
ELT	Emergency Locator Transmitter
FOD	Foreign Object Damage (Debris)
GRP	Glass Reinforced Plastic
hrs	hours
i.f.d.	in flight direction
JNP	Jahresnachprüfung (annual inspection, annual airworthiness review)
LED	Light Emitting Diode
LH	left hand
LR	Limited reusability (Parts or components that can be used only once or a limited number of times, such as self-locking nuts, split pins, ...)
LTA	Lufttüchtigkeitsanweisung (AD, issued by the Airworthiness Authority)
MAP	Manifold Absolute Pressure
MI	Manufacturer Information [Letter] (dt. Herstellerinformation)
MLL	Manufacturer Life Limit
MMM	Manufacturer Maintenance Manual
N/A	not applicable
NPI	non procurable item
OAT	Outside Air Temperature
PC	Procurement Code
PIT	procure item through
POH	Pilot's Operating Handbook
Qty.	Quantity
RBT	Rotor Bearing Temperature
rcv	receive
rec.	recommended
RH	right hand
RPM	Revolutions Per Minute
SB	Service Bulletin
SoC	Statement of Compliance
sqm	square metre(s)
STP	Stückprüfung (C of A, i.e. conformity of airworthiness)
TADS	Type Approval Data Sheet (dt.: Geräte-Kennblatt)
TBO	Time Between Overhaul
VPP	Variable Pitch Propeller
VSI	Vertical Speed Indicator
xmt	transmit
yr	year(s)

Service Bulletin (SB) and Airworthiness Directives (AD)

Service Bulletin (SB), old designation Manufacturer Information [Letters] (MI) (Herstellerinformationen) or Airworthiness Directives (AD) will be incorporated into the Maintenance Manual with the next revision.

Contents

CHAPTER 00 - INTRODUCTION / AIRCRAFT GENERAL	3
General	3
CHAPTER 01 - GENERAL	4
01-11-00 Definitions, Terms and Standard Procedures	4
01-12-00 Standard Bolt Torques	6
01-21-00 Standard Commercial Tools	6
01-91-00 Conversion Tables	7
CHAPTER 02 - TOOLS, SPARES AND CONSUMABLE MATERIALS	9
02-51-00 Consumable Materials	9
CHAPTER 03 - MINIMUM EQUIPMENT REQUIREMENT	10
CHAPTER 04 – MANUFACTURER LIFE LIMITATIONS	11
CHAPTER 05 - TIME LIMITS, INSPECTIONS & CHECKS	12
05-10-00 Time Limits	12
05-20-00 Scheduled Inspections & Checks	13
Daily / Pre-Flight Check	13
Complementary / Servicing Tasks	13
25 hrs Inspection (one-time / non-recurrent)	13
100 hrs / Annual Inspection	13
05-21-00 Temporary Scheduled Inspections & Checks	13
05-30-00 Unscheduled Inspections	14
05-50-00 Conditional Inspections	14
05-51-00 Inspections - Special Operational Conditions	14
Operation in sand or dust	14
Winter operation	14
05-55-00 Inspections - Special Operational Incident	15
Suspected hard landing	15
Rotor contact with obstacle	15
Propeller contact with obstacle or external impact	15
Birdstrike	15
Lightning strike	16
05-60-00 Ground Test Run	16
05-70-00 Functional Test Flight	16
05-90-00 Maintenance Records & Aircraft Logs	16
CHAPTER 06 - DIMENSIONS & AREAS	17
CHAPTER 07 - LIFTING / JACKING / SHORING	18
CHAPTER 08 - LEVELING & WEIGHING	18
CHAPTER 09 - TOWING & TAXIING	18
CHAPTER 10 - PARKING, STORAGE & RETURN TO SERVICE	18
CHAPTER 11 - PLACARDS & MARKINGS	19
CHAPTER 12 - SERVICING	21
12-10-00 Cleaning	21
12-20-00 Lubrication	21
Lubrication: Teeter hinge	21
Lubrication: Pre-rotator drive coupling sleeve	21
12-30-10 Servicing: Engine Air Filter	21
12-30-20 Servicing: Tire Pressure	21
12-30-30 Servicing: Battery	22
12-30-40 Servicing: Engine Coolant	22
12-40-00 Replenishing/Replacement of Fluids	22
CHAPTER 13-17 – UNASSIGNED / N/A	22



CHAPTER 18 - VIBRATION & NOISE ANALYSIS	23
CHAPTER 19–20 – UNASSIGNED / N/A	24

CHAPTER 00 - INTRODUCTION / AIRCRAFT GENERAL

General

The Cavalon is a 'new generation' gyroplane with 3-bladed push propeller and a 2-blade aluminium main rotor system with swivelling rotor head and split mast with integrated rotor vibration damping. It features monocoque cabin with glazed canopy, stainless steel mast, engine support and keel tube. Cabin, cowlings, covers and stabilizer with rudder are made from glass fibre reinforced (GRP) plastic.

The tricycle gear with GRP (glass fibre reinforced plastic) suspension bow features a steerable nose gear.

Rotor flight control comprises conventional linkage and push-pull control cables.



CHAPTER 01 - GENERAL

01-11-00 Definitions, Terms and Standard Procedures

The following definitions, procedures and words with special meanings are used in this manual:

adjust	To put in specified position or condition, usually using tools or devices Example: Adjust the clearance to 1 mm
Check (noun)	A set of check items to be performed. Example: pre-flight check
check (verb)	To make sure that the item is present and/or a given requirement is fulfilled. No tools are required. Example: Warning Lights...Check NONE
Critical Part (CP)	“Critical Parts” are those parts whose failure during ground or flight operation could have a disastrous effect on the gyroplane.
dent	Depression in a surface having area and depth with no sharp edges (see also ‘nick’)
discard	Put away in order to exclude inadvertent or intentional re-use of the item. Comply with FOD procedures.
dispose of	Discard item or substance while employing strict procedures, such as environmental or legal requirements.
hand-tighten	Use the bare hand without any tools, gloves or extra efforts
inspect / examine	To look carefully at an item and compare with its standard or specification. Tools or devices may be needed. The condition may be explicitly specified (example: no corrosion). Generally, or if not otherwise stated, inspect/examine means: Make sure that the item <ul style="list-style-type: none"> - is complete - is correctly attached - has no loose parts - shows no signs of leaks - is not cracked or damaged - is not worn Make sure that <ul style="list-style-type: none"> - the surface protection is not damaged - all locking devices are installed correctly Make sure that items such as pipes, hoses and cables <ul style="list-style-type: none"> - look serviceable - do not rub against other items For log books and other technical records: <ul style="list-style-type: none"> - find pending faults - make sure they are up-to-date and correctly maintained
Inspection	Maintenance procedure to be performed as described in this manual. Example: 100 hrs / Annual Inspection
maintenance	Any one or combination of overhaul, repair, inspection, replacement, modification or defect rectification of an aircraft or component, with the exception of pre-flight inspection

measure	To find out dimensions, capacity or quantity of something. Except for counting of smaller numbers, calibrated measurement devices are needed.
monitor	To watch a parameter or item over a certain period of time in order to read an exact value, derive a trend or identify a change caused by an event. Example: monitor rotor speed indication, monitor RPM drop, ...
nick	A dent with sharp edges (see also 'dent')
re-torque	Refer to procedure 'torque-tighten'. In contrary to procedure 'torque check' attachment hardware may rotate during re-torquing.
Record (noun)	Technical name for a documentation that shows the accomplishment of maintenance tasks or other activities, usually stating the responsible person's name and date of compliance.
record (verb)	To make an (official) entry in a maintenance record.
remove securing hardware	Cut open and remove split pins, lock wire, and such. Wear eye protection. Hold securing hardware with other hand to prevent particles from darting around. Collect all splinters and particles of securing hardware and discard.
replace	To remove an unserviceable item and install a serviceable in the same location
servicing	Simple tasks such as lubrication and cleaning, checking and adjusting of air tire pressure, replenishing of fluids
set	To change (or verify) status of equipment to a given parameter, condition or mode. Example: set altimeter sub-scale to 1013 hPa
torque-check	Refer to procedure 'torque-tighten'. Check with the (minimum) torque value supplied. Attachment hardware must NOT turn! If rotation of attachment hardware was noticeable the torque check FAILED. Refer to procedure described in Job Card.
torque-tighten	Use a calibrated tool with the correct range and handle properly and carefully. Set tool to minimum torque (if min. and max. torque values are provided). Use stretched fingers at the long end of the tool and counterhold directly at the pivot point. Click-Type: Stop upon the first clicking. If multiple clicking is heard or further rotation is suspected, open/unscrew and repeat. Replace attachment hardware if appropriate. In order to align attachment hardware (for example in case of a split pin) adjust tool to the maximum allowed torque and tighten carefully until hardware aligns. NO clicking must be heard! If clicking was heard, redo the complete procedure while trying different attachment hardware and/or in different installation position.
verify	Check that a certain dimension or condition, or set of these, is in-line with given specifications. In order to do so, a special (measurement) procedure will be required and the reference to comply with will be specified.

If not otherwise stated the following standards are based on aeronautical regulations and recommendations (AC43.13-1B), industry and safety standards, and general practices, and shall be applicable throughout this manual. Examples are:

- Torquing
- Securing (handling of lockwire and other securing hardware)
- Removal of securing hardware
- FOD (foreign object damage) protection
- Discard and disposal procedures
- Handling of hazardous material
- Workplace safety

01-12-00 Standard Bolt Torques

Standard torques are M4 2-3 Nm, M5 5-6 Nm, M6 11 +/-1 Nm, M8 25 +/-3Nm, M10 35 +/-4Nm. Always assess the joint to be tightened and use engineering judgement – do not overtighten plastic or unsupported tube joints!

01-21-00 Standard Commercial Tools

Most maintenance tasks on the Cavalon can be conducted using standard, commercially available metric tools. In addition, the following standard commercial tools are required:

- Inclinator (digital) / Digital spirit level with angle gauge
- Spring balance / Dynamometer
- Tensiometer (to measure cable tension)
- 1m aluminium ruler
- Fuel hose clamp
- Torque wrench (in required torque ranges)
- Multimeter
- 3 m-tape measure
- Torch light
- Tyre pressure gauge / tyre filling device

01-91-00 Conversion Tables

LENGTH / DISTANCE				
Multiply	by	to obtain / Multiply	by	to obtain
m (metre)	3.28	ft (feet)	0.305	m
mm (millimetre)	0.039	in (inch)	25.4	mm
km (kilometre)	0.54	nm (nautical mile)	1.852	km
SPEED				
Multiply	by	to obtain / Multiply	by	to obtain
m/s (metre per second)	196.85	ft/min (feet per minute)	0.0051	m/s
km/h (kilometre per hour)	0.54	kts (knots)	1.852	km/h
km/h (kilometre per hour)	0.62	mph (miles per hour)	1.61	km/h
PRESSURE				
Multiply	by	to obtain / Multiply	by	to obtain
hPa (hectopascal)	1.0	mbar (millibar)	0.0001	bar
bar (Bar)	14.50	psi (lb per square inch)	0.0689	bar
bar (Bar)	0.0295	inHg (inch mercury)	33.864	bar
FORCE / WEIGHT				
Multiply	by	to obtain / Multiply	by	to obtain
N (Newton)	2.205	lbf (pound force)	0.4536	N
N (Newton)	0.1019	(respective force of 1 kg)	9.81	N
MASS (WEIGHT)				
Multiply	by	to obtain / Multiply	by	to obtain
kg (kilogram)	2.2046	lb (pound)	0.4536	kg
VOLUME				
Multiply	by	to obtain / Multiply	by	to obtain
l [or ltr] (Litre)	0.2642	US gal (US gallons)	3.7854	l/ltr
l [or ltr] (Litre)	1.057	US qts (US quarts)	0.946	l/ltr
l [or ltr] (Litre)	0.0164	in ³ (cubic inch)	0.946	l/ltr
TORQUE				
Multiply	by	to obtain / Multiply	by	to obtain
Nm (Newton metre)	0.738	lbf.ft. (pound-foot)	1.3558	Nm
Nm (Newton metre)	0.113	lbf.in. (pound-inch)	8.851	Nm
kgmm	0.0098	Nm	101.94	kgmm

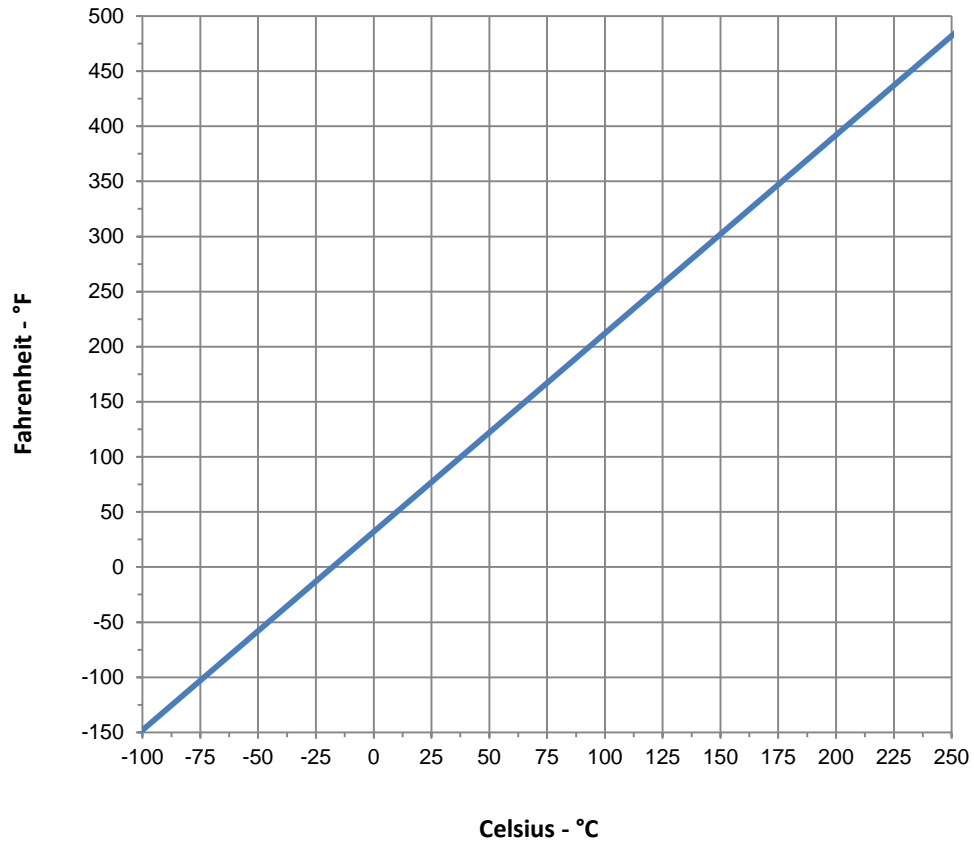

Celsius-Fahrenheit Conversion Chart

CHAPTER 02 - TOOLS, SPARES AND CONSUMABLE MATERIALS

02-51-00 Consumable Materials

Consumable Material (CM) referenced throughout this Maintenance Manual is coded AG-XXX-NN where NN is a consecutive number and XXX represents the material code according to the classification listed below:

Class	Description	Class	Description
BAS	BONDING, ADHESIVES AND SEALANTS	LUB	LUBRICANTS
CCM	CHEMICAL CONVERSION MAT.	MSC	MISCELLANEOUS
CLA	CLEANING AGENTS	OIL	OILS
CPA	CORROSION PREVENTIVE AGENTS	PNT	PAINT AND LACQUERS
FUE	FUELS	PRM	PRIMER, PREPARATION FOR PAINTING
GRS	GREASES	PRS	(STORAGE) PRESERVATION
HYF	HYDRAULIC FLUIDS		

The following consumable materials are referenced in the Maintenance Manual:

CM-Item	Material / Description	AutoGyro Order Codes
AG-BAS-01	Loctite 221 red	88-00-00-S-30487
AG-BAS-02	Loctite 243 blue	88-00-00-S-30483
AG-BAS-03	Loctite 542 red	88-00-00-S-30488
AG-BAS-04	Loctite 638 green	88-00-00-S-30485
AG-CPS-01	'Hohlraumspray'	88-00-00-S-34197
AG-GRS-01	Silicon grease Lagermeister 2002	88-00-00-S-30477
AG-LUB-01	Ballistol Öl Universal	88-00-00-S-31816 (5L can) 88-00-00-S-31846 (2ml injection syringe) 88-00-00-S-31847 (5ml injection syringe)
AG-LUB-02	Anti-Seize Spray	88-00-00-S-31590
AG-LUB-03	HHS 2000	88-00-00-S-30476
AG-OIL-01	Oil Shell Advance AX7 10W-40 API SG 1	88-00-00-S-31665

CHAPTER 03 - MINIMUM EQUIPMENT REQUIREMENT

In accordance with the Pilot's Operating Handbook (POH) Section 2.11 the following equipment must be operative for flight

- Air speed indicator
- Altimeter
- Compass
- Side Slip Indicator
- Rotor RPM indicator
- Engine instruments (oil pressure, oil temperature, RPM, CHT)
- HOBBS meter
- Pre-rotator

Depending on the equipment state or relevant condition a limited or restricted operation may be granted to facilitate maintenance efforts and operability.

Equipment / System	Condition	Limitation/Restriction
Compass	Defective	Local flights within the traffic pattern and with ground reference.
Rotor RPM indicator	Defective	Flight to a maintenance facility.
Pre-rotator	Defective / No function R-RPM indicator working	Flight to a maintenance facility under the following conditions: <ul style="list-style-type: none"> • Experienced pilot as sole occupant • Concrete/asphalt runway with a minimum of 5 times the normal required take-off roll distance available • Second briefed person 'handpropping' the rotor while engine/propeller is off • Steady, laminar headwind
Pre-rotator	Malfunction, R-RPM > 120 R-RPM indicator working	Flight to a maintenance facility under the following conditions: <ul style="list-style-type: none"> • Experienced pilot • Concrete/asphalt runway with a minimum of 3 times the normal required take-off roll distance available • Steady, laminar headwind

CHAPTER 04 – MANUFACTURER LIFE LIMITATIONS

For the safe operation over the specified lifecycle of the aircraft and liability reasons the following manufacturer limitations shall apply. In case the component has an operating hours and calendric time limit the first limit shall apply.

Note that at expiration of the specified manufacturer life limit (MLL) the component shall be replaced for your own safety, independent of its condition.

ATA	Equipment / System	MLL
24-30-00	Battery	See manufacturer
25-10-00	Seat belts	10 yrs
25-60-00	ELT Battery	See manufacturer
28-20-00	Fuel filter	200 hrs / 2 yrs
28-20-00	Fuel pumps	5 yrs (R912)
28-20-00	Primary fuel pump	1000 hrs (R914)
32-20-00	Nose gear rubber damper	5 yrs
62-00-00	Rotor System II	2500 hrs
62-31-00	Rotor main bearing	1500 hrs
62-32-00	Gimbal head bolts	1500 hrs / 5 yrs
62-51-00	Mast bolts	1500 hrs / 5 yrs
62-51-00	Mast mounting bushings	1500 hrs / 5 yrs
67-00-00	Push-pull cables	1500 hrs
71-20-00	Engine mounting bushings	1500 hrs / 5 yrs

Status and lifetimes of components, liquids and fluids is listed in the Event and Configuration Log (AG-F-ECL) form. The initial Event and Configuration Log is delivered with the gyroplane by AutoGyro. An empty form is provided for download on the AutoGyro web site.

CHAPTER 05 - TIME LIMITS, INSPECTIONS & CHECKS

For safe operation and continued airworthiness over the specified lifecycle of the aircraft the following inspection schedule shall apply. Note that specified tolerances must NOT be accumulated!

Task	Interval	Recurrence	Tolerance
Daily / Pre-Flight Check	Before flight / daily	Each	N/A
Complementary / Servicing Tasks	5 hrs (rec.)	Each	N/A
25 hrs Inspection	25 hrs	Once	+/- 5 hrs
100 hrs / Annual Inspection	100 hrs / 1 yr	Each	+/- 10 hrs
Supplemental Inspection	1500 hrs / 5 yrs	Each	-

The 25 hrs inspection has to be performed once, within the specified tolerance.

The 100 hrs inspection has to be performed every 100 hours, within the specified tolerance, at latest within 12 months, counted from issue of the aircraft's Statement of Compliance (Stückprüfung) or Annual Inspection (JNP).

Note that tolerances do not accumulate! However, a preponed (earlier) inspection outside the tolerance will reduce the next inspection due cycle accordingly.

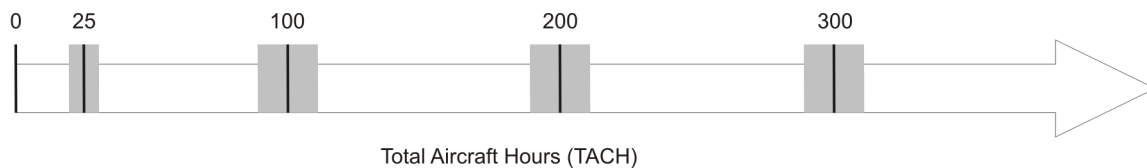

(Total aircraft hours, counted from engine start to engine shut-down, i.e. HOBBS meter)

05-10-00 Time Limits

In addition to time limits for inspection items and checks the following time limits for inspection or overhaul of respective components or replacement of liquids and fluids apply. Please refer also to the engine manufacturer's manual and time limits specified herein, as well as [CHAPTER 04 - Airworthiness Limitations!](#)

Components

ATA/Ref.	Equipment / System	Time Limit
53-00-00	Monocoque structure (incl. keel tube support), keel tube	on condition

Liquids and Fluids

ATA/Ref.	Equipment / System	Time Limit
75-00-00	Engine coolant (acc. to coolant manufacturer)	at latest 5 years
79-00-00	Engine oil (acc. to engine manufacturer)	at latest 100 hrs

Refer to [CHAPTER 12](#) concerning replenishing/replacement procedures and types of liquids and fluids.

Status and lifetimes of components, liquids and fluids is listed in the Event and Configuration Log (AG-F-ECL) form. It is the obligation of the maintenance facility to keep this form current. An empty form is provided for download on the AutoGyro web site.

05-20-00 Scheduled Inspections & Checks

Daily / Pre-Flight Check

All daily or pre-flight check list items consist of visual checks and do not replace professional mechanical inspection and maintenance. The **Daily / Pre-Flight Checklist** for the standard Cavalon gyroplane is provided in the current Pilot's Operating Handbook.

Note that there is no 'post-flight' inspection mentioned. It is reasonable, however, to perform parts of the pre-flight inspection after the last flight of the day in order to take maintenance action in advance, if necessary.

Complementary / Servicing Tasks

The following tasks have to be performed in-between 100hrs inspections and may be performed on an operational level by the pilot or a trained person.

Task	Interval	Tolerance
Lubrication: Teeter hinge (see Ch. 12 – Servicing)	5 hrs (rec.)	N/A
Lubrication: Pre-rotator drive coupling sleeve	as req.	N/A
Cleaning/replacement: Engine air filter	as req.	N/A

25 hrs Inspection (one-time / non-recurrent)

The inspection items of the 25 hrs inspection are covered within the 100 hrs inspection protocol, which is available for download.

100 hrs / Annual Inspection

The maintenance protocol of the 100 hrs / Annual Inspection (AG-F-PCA-MT) is available for download.

05-21-00 Temporary Scheduled Inspections & Checks

Temporary Scheduled Inspections and Checks may be introduced by MIs or AD's (if any). Notice of, and compliance with ADs is mandatory. If necessary, AutoGyro GmbH will point out the existence of such information and will provide detailed procedures to registered service partners and owners.

Important Note: Temporary scheduled inspections introduced by the engine/powerplant manufacturer will not be covered by process. As a contribution to fleet safety, AutoGyro may point out the existence of such information, if possible.

05-30-00 Unscheduled Inspections

In case of the following events or occurrences, unscheduled inspections have to be performed.

Event / Occurrence / Unusual Condition	Action / Reference
Rotor vibration	see CHAPTER 18
Propeller vibration	see CHAPTER 18

If in doubt contact AutoGyro customer support.

05-50-00 Conditional Inspections

Depending on the conditions the gyroplane is operated in or special operational incident the following conditional inspection may apply:

05-51-00 Inspections - Special Operational Conditions

Condition	Action / Reference
Operation in sand or dust	see below
AVGAS	engine manufacturer documentation
Winter operation	see below

Operation in sand or dust

- Refer to engine manufacturer documentation
- Inspect/change air filter regularly
- Reduce 100 hrs inspection interval to 50 hrs
- Apply propeller leading edge protection strip
- Operation with keel tube fin (recommended)

Winter operation

The cooling system for the cylinder heads of the engine is filled with a mixture of anti-freeze and water, which gives freezing protection down to -20°C. Check protection temperature of the coolant and add anti-freeze, if necessary.

If temperatures are expected to fall below protection temperature, drain the coolant, and if required for service, refill with pure antifreeze. As anti-freeze ages, renew the coolant every five years. Read the engine manual for the manufacturer's recommendations.

During winter operations the necessary operating temperature for oil and cooling agent may not be reached. This can be compensated by taping some portion of the coolers. Monitor all engine temperatures closely after having the coolers taped and modify, if necessary.

When using heated clothing be aware of the electrical power demand in regard to the generator performance. Do not exceed the generator output value in order not to drain the battery. A loss of electric power affects avionics and radio communication and can lead to an engine failure in case of ROTAX 914 engine (depending on configuration).

Before each flight inspect all control cables for free and easy movement and sufficient lubrication.

05-55-00 Inspections - Special Operational Incident

Event / Occurrence / Unusual Condition	Action / Reference
Suspected hard landing	see below
Rotor contact with obstacle	see below
Propeller contact with obstacle or external impact	see below
Birdstrike	see below
Lightning strike	see below

Suspected hard landing

In case of a suspected hard landing perform the following checks:

- Inspect nose gear, attachment, fork, linkage and wheel bearing
- Inspect main gear axles and attachment
- Examine possible rotor / propeller strike → see 'Rotor / propeller contact with obstacle'
- CRITICAL: Inspect main gear suspension bow (body attachment and both axle attachments ok, no cracks)
- CRITICAL: Inspect fuselage, frame and attachment point for possible deformation or cracks. Perform levelling procedure (see JobCard [08-20-00 2-1](#))
- CRITICAL: Inspect engine mounting and propeller to frame clearance approx. 5 cm
- CRITICAL: Perform a rotor alignment check

Defective components must be replaced. In case one or more of the items marked 'CRITICAL' are found defective or out of tolerance, contact AutoGyro customer support.

Rotor contact with obstacle

Rotor contact with obstacle include any rotor strike of the standing or turning rotor with an obstacle, including propeller and fuselage structures. In case of rotor contact with obstacle:

- Perform a rotor alignment check and adjust, if necessary
- Examine damage of aluminium rotor profile:
 - allowed damage: dent with max. depth of 1 mm
 - CRITICAL damage: nick(s)
- In case the turning rotor hit the stabilizer/rudder, a detailed inspection of the affected components must be performed.

In case CRITICAL damage is found, the rotor system must be replaced. Contact AutoGyro customer support.

Propeller contact with obstacle or external impact

Refer to engine manufacturer documentation. Perform tap test on propeller blades.

Birdstrike

- Perform detailed inspection of all affected component
- If rotor blades are affected, proceed according to 'Rotor contact with obstacle'
- If propeller is affected, proceed according to 'Propeller contact with obstacle or external impact'

Lightning strike

A lightning is likely to have caused invisible damage to many components, especially the main rotor bearing. The aircraft must not be flown until satisfactory inspection has been undertaken and any rectification has been completed.

05-60-00 Ground Test Run

The maintenance protocol of the Ground Test Run (AG-F-PGR-MT) is available for download.

05-70-00 Functional Test Flight

The maintenance protocol of the Functional Test Flight (AG-F-PTF-MT) is available for download.

05-90-00 Maintenance Records & Aircraft Logs

An illustrated 'Parts List' (AutoGyro Parts List) will be compiled individually and delivered with each gyroplane.

Forms are available for download.

An 'Event and Configuration Log' (ECL) is delivered with the aircraft by AutoGyro and shall be kept current by the maintenance facility. An empty form (AG-F-ECL) is provided for download.

CHAPTER 06 - DIMENSIONS & AREAS

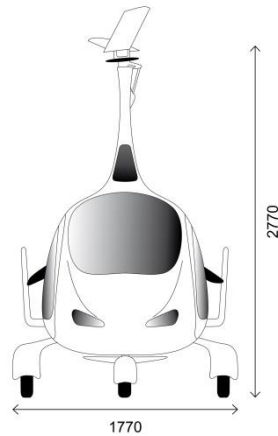
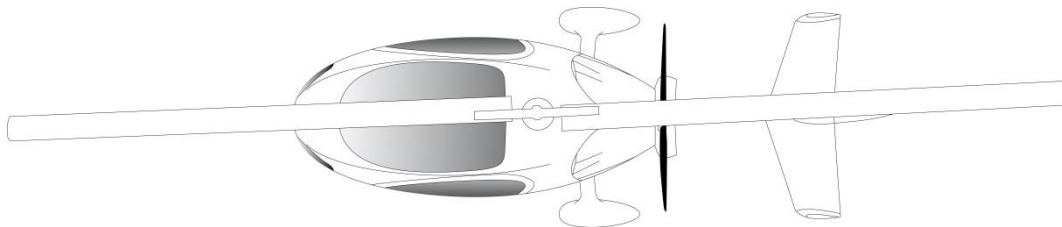
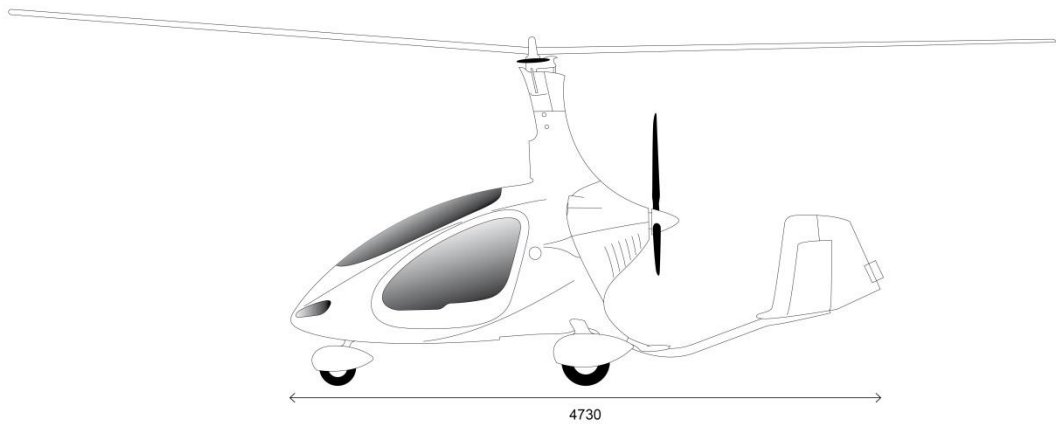

Length	4.60 m
Width	1.75 m
Height	2.82 m
Rotor diameter	8.4 m
Rotor disc area	55.4 sqm
Propeller diameter	1.72 m

CHAPTER 07 - LIFTING / JACKING / SHORING

See Job Card [07-00-00 2-1](#) in Part E of this manual.

CHAPTER 08 - LEVELING & WEIGHING

Weighing shall be performed in a draft-free hangar on level ground, with the aircraft defueled to minimum useable fuel.

Make sure each wheel of the gyroplane is located centred on the scales.

The weighing report AG-F-WRP-MT is available for download.

CHAPTER 09 - TOWING & TAXIING

Experience shows that aircraft may be exposed to much higher loads when operated on ground, than when in flight. Such loads caused by rumbling on rough terrain, or bouncing the aircraft over the hangar threshold may easily exceed the design load in peak.

Use caution when handling the gyroplane on ground. Care must be taken when pushing at the rudder or at the outer stabilizers. Avoid excessive swing of the rotor blades as repeated bending ultimately leads to fatigue or damage.

CHAPTER 10 - PARKING, STORAGE & RETURN TO SERVICE

Parking up to 6 months

No special measures need to be taken.

NOTE Don't let E10 remain in the fuel system for unnecessary long time or for long-term storage!

Parking more than 6 months

- Refer to engine manufacturer documentation
- Maintain battery charged

CAUTION No overwinter survival mode (snowflake) with Ctek charger MXS3.8 for Super B batteries.

- Unload wheel gear
- Cover aircraft with a light plastic tarpaulin or cloth

Long-term Storage

Contact AutoGyro

Return to Service

Perform a 100 hrs Inspection.

CHAPTER 11 - PLACARDS & MARKINGS

In clear view of the pilot:

Only VFR day is approved
Aerobatic flight prohibited!
Low-G manoeuvres prohibited!
Flight in icing conditions prohibited!
For additional limitations see Flight Manual!

Max. gross weight: _____
Empty weight: _____
Max. useful load: _____

At RH seat:

Max. weight in seat: 110 kg
Min. weight in seat: 60 kg

At LH seat:

Max. weight in seat: 110 kg

Solo from right hand seat only

Occupant warning (front and aft seat):

OCCUPANT WARNING
This aircraft has not been certified
to an international requirement

At each storage compartment behind seats:

Max. load: 10 kg
W&B must be respected!

At fuel filler neck:

Min. ROZ 95
AVGAS 100LL

Tank Capacity 100 litres

At oil filler neck:

Engine Oil: _____
Approved oil types see engine manual!

At fuel shut-off valve:

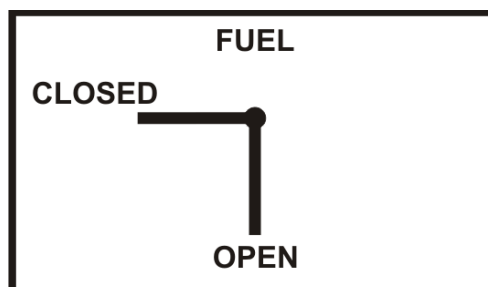

At both static ports:

Static Port
Do not obstruct!

CHAPTER 12 - SERVICING

12-10-00 **Cleaning**

Care and regular cleaning of engine, propeller, rotor system and fuselage is the basic foundation for airworthiness and reliability. Therefore, the gyroplane should be cleaned after every last flight of the day or more often, if environmental conditions dictate.

In order to protect the gyroplane against dirt, dust, bird soil, and sunlight, the aircraft should be covered with a light plastic tarpaulin or cloth. Openings to the engine, service access ports and airspeed indicator should be closed after the flight (insects, birds etc.).

Contamination can be cleaned with clean water, possibly with mild cleaning additives. To clean the rotor it is best to soak contamination with a cloth or towel, wipe with soft or micro-fibre cloth, and rinse thoroughly with water.

12-20-00 **Lubrication**

Component	Application	Reference
Lubrication: Teeter hinge	5 hrs (recomm.)	see below
Lubrication: Pre-rotator drive coupling sleeve	as required	see below

See [CHAPTER 05](#) for respective time limits.

Lubrication: Teeter hinge

The teeter hinge consists of a steel bolt running in special Teflon coated bushings. In order to provide proper bearing action and to avoid wear and bearing play, which will cause rotor vibration in consequence, regular lubrication is essential. In order to do so, the best practise is to perform work steps 5 to 7 from Job Card 62-11-00 6-1 INSPECTION: ROTOR – TEETERING PARTS. Make sure to apply grease also on the outer (secondary) bearings inside the teeter tower.

Lubrication: Pre-rotator drive coupling sleeve

Apply a thin layer of lubricant AG-LUB-03 on coupling sleeve when in extended position in regular intervals, at latest when the sliding surface feels dry or after flight through rain. Mast cover must be removed!

12-30-10 **Servicing: Engine Air Filter**

The air intake filters need to be replaced or cleaned according to the manufacturer's recommendation. Depending on environmental conditions, such as dust, sand, or pollution the recommended rate of maintenance should be increased as required. Engine cowling must be removed!

12-30-20 **Servicing: Tire Pressure**

Main wheels	1.8 – 2.2 bar
Nose wheel	2.0 – 2.4 bar

NOTE: Green valve caps are used when the tire is filled with nitrogen.

12-30-30 Servicing: Battery

The aircraft is fitted with a maintenance-free gel electrolyte battery. Maintenance is therefore limited to outside soundness, correct attachment, and cleaning. Check integrity of the battery as leaking fluid contains corrosive sulphuric acid which would lead to extensive damage when contacting the framework and attachments.

Charge the battery only with a charging device which is suitable for gel electrolyte batteries.

CAUTION: The battery must never be deep discharged, as it will be damaged. If so, it might need to be replaced.

CAUTION: No overwinter survival mode (snowflake) with Ctek charger MXS3.8 for Super B batteries.

12-30-40 Servicing: Engine Coolant

The cooling system for the cylinder heads of the engine is filled with a mixture of anti-freeze and water, which gives freezing protection down to -20°C. Check protection temperature of the coolant and add anti-freeze, if necessary.

If temperatures are expected to fall below protection temperature, drain the coolant, and if required for service, refill with pure antifreeze. As anti-freeze ages, renew the coolant every five years. Read the engine manual for the manufacturer's recommendations.

As a minimum, coolant must be visible in the overflow bottle resp. on the dip stick. The maximum coolant level is defined by the twin rings marking on the Fuel and Engine Coolant Dip Stick with the dip stick held at the side with the triple rings. A larger depiction of the dip stick is provided in the POH.

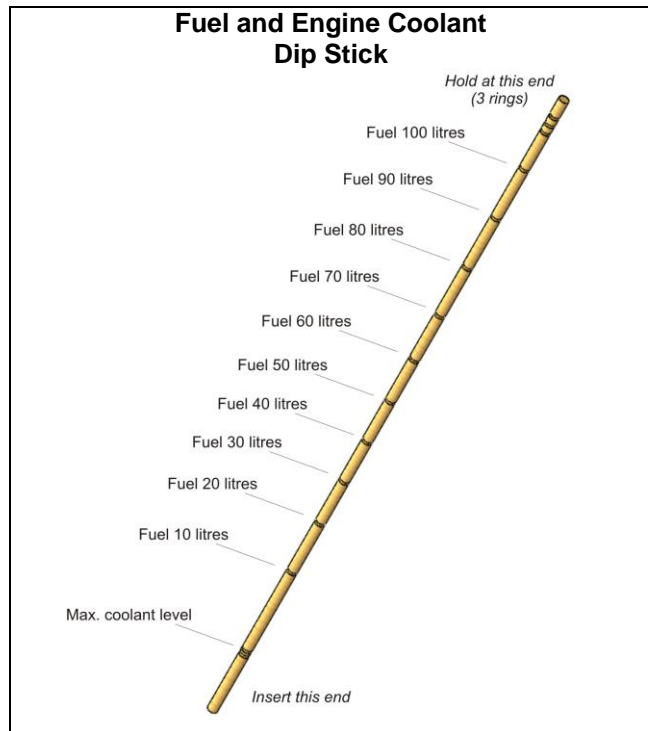

12-40-00 Replenishing/Replacement of Fluids

Liquid / Fluid	Max. Filling Qty.	Type / Code
Engine coolant	3.8 ltr	as documented
Engine coolant with cabin heating (option) installed	4.2 ltr	as documented
Engine Oil	3.4 ltr	as documented

See [CHAPTER 05](#) for respective time limits.

CHAPTER 13-17 – UNASSIGNED / N/A

CHAPTER 18 - VIBRATION & NOISE ANALYSIS

Vibration may be induced by the rotor system, the propeller or even the engine. Finding out the cause for vibration and its proper cure requires experience and special equipment. This is why vibration analysis and related maintenance can only be performed by specialized service partners (maintenance level 'S'), or AutoGyro GmbH, Germany directly.

The following tests or fault isolation procedures should be performed in order to exclude systematic errors in case of rotor vibration:

- rotor system cleanliness
- check/verify correct installation position of the shim washers relative to teeter block and teeter tower (one or two dot markings on block, shim washer and teeter tower must align)
- check for possible play in teeter bearing in axial or radial direction
- check rotor system alignment (see Job Card [62-11-00 5-1](#))
- check for possible play in rotor bearing
- adjust (increase) rotor control friction (see Job Card [62-32-00 5-1](#))

In case of unusual vibration, contact AutoGyro or an AutoGyro specialized service partner. If possible, try to describe the type of vibration as precise as possible as this will help to save time to reproduce and troubleshoot, or even allow a first remote assessment. The following table provides a basic classification.

Vibration appearance / sensation / parameter
Lateral (left-right / back-forth) vibration with approximately 6 per second amplitude
Vertical (up-down) vibration with approximately 12 per second amplitude
Free-stick movement – carefully release control stick (if possible/safe) and describe path and displacement of control stick head
Flight condition (weight, speed) with highest vibration level
Rotor RPM
Higher frequency vibration (around 50 Hz, like an electric razor), changing with RPM
Higher frequency vibration, frequency and amplitude significantly changing with power setting, possibly irregular or erratic
RPM or power setting with highest vibration levels

Noise is mainly created by the propeller. Engine and muffler play a secondary role in noise emission, as long as intact. Any deficiencies could be easily identified by a visual inspection or tap test. A defective muffler can be refilled with insulating material. Repair as necessary.

Propeller noise is emitted by the fast turning blade tips and usually increases exponentially with RPM and speed due to interaction of air disturbances with the blade tips.

As noise is a subjective perception, only measurement will provide reliable data. However, the following table provides elements and countermeasure to troubleshoot and cure in case of unusual noise emission.

Possible causes for noise / countermeasures
Check propeller condition (cleanliness, erosion, damaged or splintered blade tips). Clean or repair propeller.
Check propeller RPM during take-off (full throttle) or cruise. Adjust/reduce if required.
Check/adjust propeller pitch. Check pitch setting of individual blades and adjust.
Check leading edge of propeller and leading edge protection strip (if installed). A damaged leading edge protection strip (loose or sticking out end) may change noise signature significantly. Replace as necessary.
Check airfilter condition and installation condition.

CHAPTER 19–20 – UNASSIGNED / N/A

Contents

CHAPTER 21 - VENTILATION / HEATING	3
21-00-00 Ventilation / Heating	3
CHAPTER 22 - UNASSIGNED / N/A	3
CHAPTER 23 - COMMUNICATIONS	3
23-10-00 Speech Communication / Radio	3
23-40-00 Interphone / Intercom	3
CHAPTER 24 - ELECTRICAL POWER	3
24-30-00 DC Generation and Battery	4
24-60-00 DC Electrical Load Distribution	4
CHAPTER 25 - EQUIPMENT / FURNISHINGS	4
25-10-00 Flight Compartment	4
25-60-00 Emergency.....	5
CHAPTER 26 - FIRE PROTECTION / FIRE WARNING	5
CHAPTER 27 - FLIGHT CONTROLS	6
27-00-00 Flight Controls.....	6
27-20-00 Flight Controls - Rudder	6
CHAPTER 28 - FUEL	7
28-10-00 Storage	7
28-20-00 Distribution.....	7
28-40-00 Indicating	8
CHAPTER 29-30 - N/A	8
CHAPTER 31 – INDICATING SYSTEM.....	8
31-10-00 Instruments & Control Panels.....	8
31-60-00 Integrated Display Systems.....	10
CHAPTER 32 - LANDING GEAR	12
32-10-00 Main Gear	12
32-10-00 Nose Gear	12
32-40-00 Wheels and Brakes	12
CHAPTER 33 - LIGHTS	12
33-40-00 Exterior	12
CHAPTER 34 - NAVIGATION	13
34-10-00 Flight Environment Data	13
34-20-00 Attitude and Direction	13
34-70-00 ATC Transponder	13
CHAPTER 35 - N/A	13
CHAPTER 36 - PNEUMATIC	13
36-11-00 Generation / Compressor	13
36-21-00 Distribution.....	13
CHAPTER 37-50 - UNASSIGNED / N/A	14
CHAPTER 51 - STANDARD PRACTICES - STRUCTURES.....	14
51-00-00 Standard Practices - Structures.....	14
CHAPTER 52 - DOORS, COVERS AND COWLINGS	14
52-10-00 Passenger / Crew	14
52-20-00 Emergency Exit.....	14
52-40-00 Service Covers and Cowlings.....	14
CHAPTER 53 - FUSELAGE	14
CHAPTER 54 - N/A	14
CHAPTER 55 - STABILIZERS	15
55-40-00 Rudder.....	15
CHAPTER 56 - WINDOWS.....	15
56-10-00 Flight Compartment / Canopy	15



56-15-00 Canopy Windows	15
CHAPTER 57-60 - UNASSIGNED / N/A	15
CHAPTER 61 - PROPELLER	16
61-10-00 Propeller assembly	16
61-20-00 Controlling.....	16
CHAPTER 62 - ROTOR	16
62-11-00 Rotor – Teetering Parts	16
62-31-00 Rotor Head Bridge, Bearing and Teeter Tower	17
62-32-00 Rotor Gimbal Head.....	17
62-41-00 Rotor RPM Monitoring	17
62-51-00 Rotor Vibration Isolation	17
CHAPTER 63 - ROTOR DRIVE	17
63-11-00 Pre-rotator.....	17
63-11-10 Pre-rotator Lower Engagement	18
63-11-20 Pre-rotator Drive	18
63-11-30 Pre-rotator Upper Engagement	18
63-51-00 Rotor Brake System	18
CHAPTER 64-66 - N/A	18
CHAPTER 67 - ROTOR FLIGHT CONTROL.....	18
67-05-00 Pitch Trim System / Rotor Brake	18
67-06-00 Roll Trim System	19
CHAPTER 68-70 - UNASSIGNED / N/A	19
CHAPTER 71 - POWER PLANT	19
71-10-00 Engine Cowling.....	19
71-20-00 Engine Mounts.....	19
71-30-00 Engine Firewalls	19
71-50-00 Engine Electrical Harness	19
71-60-00 Engine Air Intakes.....	19
71-70-00 Engine Drains	19
CHAPTER 72 TO 74 - ENGINE RELATED.....	20
CHAPTER 75 - AIR / ENGINE COOLING.....	20
CHAPTER 76 - ENGINE CONTROLS	21
76-10-00 Power Control / Choke	21
76-20-00 Engine Shutdown / Emergency	21
CHAPTER 77 - ENGINE INDICATING	21
77-10-00 Power.....	21
77-20-00 Temperature	21
77-40-00 Integrated Engine Instrument Systems	22
CHAPTER 78 - EXHAUST	22
78-00-00 Exhaust.....	22
CHAPTER 79 - OIL SYSTEM.....	22
79-11-00 Storage / Oil tank.....	22
79-20-00 Distribution and Cooling	22
79-21-00 Oil Hoses and Lines	22
79-22-00 Oil Cooler.....	22
79-30-00 Indicating	22

CHAPTER 21 - VENTILATION / HEATING

21-00-00 Ventilation / Heating

Each of the two cabin doors features an adjustable fresh air vent and one sliding window with pivoting vent for ventilation. The sliding window can be used as viewing hatch in case of emergencies and is wide enough to reach through with a hand. For demisting and /or cabin ventilation, open and direct the round air vents and pivoting vents as required. Used air can escape through an outlet at the bottom of the cabin.

Cabin heating (if installed) is controlled by a labelled lever in the centre console. In order to switch cabin heating on, the lever must be moved to the front which will activate the cabin heat blower fan by means of a micro switch. Heat output / temperature can be controlled corresponding to the position of the lever. When activated, an electrical blower fan sucks air from the leg room and blows it through a heat exchanger, which is connected to the engine cooling water circuit. Warm air escapes through outlets at the dashboard below the front window, at two adjustable nozzles, and is redirected to the leg room.

Concerning heating control, see [76-10-00 Power Control / Choke](#) for reference.

CHAPTER 22 - UNASSIGNED / N/A

CHAPTER 23 - COMMUNICATIONS

23-10-00 Speech Communication / Radio

The communication system consists of an integrated airband radio system installed in the instrument panel. Different versions may be possible. Please refer to the manufacturer's specifications and manuals for reference. Wiring diagrams are provided in Part D of this document. Different possible cockpit layouts are described in [31-10-00 Instruments & Control Panels](#).

23-40-00 Interphone / Intercom

The standard intercom system features standard headset sockets (TRS / Tip Ring Sleeve) with additional XLR-3 socket for active headset power supply. Sockets are provided at the aft console between the crew seats. The intercom amplifier and VOX control is integrated in the respective radio. See manufacturer's manual for additional information.

As the intercom function is an integral part of the radio system, please refer to [23-10-00 Speech Comm. / Radio](#).

CHAPTER 24 - ELECTRICAL POWER

The 12V DC electrical system consists of an engine driven electrical generator, a battery, master switch, indicators, switches, electrical consumers, and cabling. With the ROTAX 914 UL engine an electrical power supply is vital for continued engine operation as this engine variant solely relies on electrically driven fuel pumps (depending on configuration).

Turning the master switch to the ON position closes the battery contact and energizes the gyroplane's electrical system. The red LOW VOLT warning light will illuminate briefly as a functional check. A steady indication, however, warns the pilot that the voltage of the system has dropped below a safe value. In this case a safety circuit (load shedding relay) will automatically disable the aircraft lights and the 12V power receptacle.

A red GEN warning light is installed to indicate that the battery is not being charged.

24-30-00 DC Generation and Battery

Direct current is provided by an engine-integrated AC generator with external rectifier-regulator (12V 20 A DC). The battery is located at the rear wall on the LH side behind the removable fire wall. A dedicated charging receptacle is available at the lower LH side of the fuselage, just before the LH engine cowling.

24-60-00 DC Electrical Load Distribution

The DC electrical load distribution system includes cockpit switches, control electronics (relays and logic components), fuses, electrical harnesses and cabling, and electrical consumers.

Electrical schematics are provided in [Part D - Diagrams and Charts](#) of this manual.

The power demand for various consumers is provided in the following table:

ATA Reference	Equipment / System	Power load
24-3	Generator	(-) 240 W
21-0	Cabin heat blower fan	32 W
23-1	Radio ATR500	2 W (rcv) / 35 W (xmt)
23-1	Radio ATR833	7 W (rcv) / 35 W (xmt)
25-1	Heated seats (ea)	96 W
28-2	Electrical fuel pump (ea)	21 W
33-4	NAV Lights LED	9 W
33-4	Strobe Lights	28 W
33-4	Landing Light (LED)	10 W
34-7	ATC Transponder TRT800H	max.10W
36-1	Pneumatic compressor	124 W (peak) / 103 W
75-0	Engine cooling fan	194 W (peak) / 97 W
85-21	Air conditioning system	(aux.generator)
85-34	Garmin 296	20 W
85-34	Garmin 496	20 W
85-34	Garmin 696	40 W
85-34	Flymap F7 / Sky-Map T7	5 W
85-34	Flymap L	35 W
85-34	Flymap L (dual screen)	70 W
85-34	Flymap XL	45 W
85-34	AvMap	10 W

CHAPTER 25 - EQUIPMENT / FURNISHINGS

25-10-00 Flight Compartment

The seats consist of seating surface as an integral part of the monocoque structure and adjustable backrest, upholstered with removable cushions. The cushions consist of a foam core covered with an easily cleanable, water-repellent fabric.

The backrest hinges are positioned by 2 countersunk Allen bolts on two seating rails. To suit to different seating positions the backrest hinges can be adjusted by removing the Allen bolts and

refitting in a different position on the rails. In addition the backrest angle can be adjusted by modifying the lengths of the telescopic tubes.

For each seat an adjustable four point harness is available.

IMPORTANT NOTE: Seat belts are Manufacturer Life Limited (MLL)!

A storage compartment is located behind each seat with a maximum capacity of 10 kg each.

25-60-00 Emergency

The gyroplane is embarked and disembarked from each side through hinged, gull-wing type doors, both doors are held open by a gas spring. In case of emergency or a jammed door, the gyroplane can be evacuated through the opposite door, if necessary.

Depending on the customer's configuration, an ELT may be installed below the LH seat. The ELT can be accessed through the service cover below the seat cushion. ELT control panel with mode indicator will be installed in the cockpit panel. If installed, please refer to the manufacturer's documentation for maintenance, time limits and testing. Be aware that the built-in battery has a limited lifetime and needs to be replaced as specified. Replacement date should be placarded in the vicinity of the device or control panel.

CHAPTER 26 - FIRE PROTECTION / FIRE WARNING

Depending on customer's configuration the gyroplane can be equipped with a Fire indicator light to alert the pilot that a certain temperature in the engine compartment has been exceeded (the engine is on fire). The fire indication circuit consists of a cable routed inside the engine compartment. The cable has two integrated wires separated by an insulation layer. At a defined temperature the insulation layer will melt and the embedded wires close contact.

Engine fire (circuit short-closed, low resistance) will be indicated by a flashing/blinking Fire indicator light in the Warning and Caution Panel. During normal operation (circuit closed, 'normal' resistance) the Fire indicator light will be off. A malfunction of the system (circuit open) is indicated by a constantly lit Fire indication. At power-on the system will perform a lamp test consisting of a series of three flashes.

When installing or repairing the fire indication cable make sure not to overtorque the attachment hardware as this might lead to uncontrolled contact of the embedded wires, which might lead to a false Fire indication.

Indicator Light	System Status
OFF	Normal Operation (normal resistance / $R \sim 1 \text{ k}\Omega$)
FLASHING	Fire, abnormal temperature (circuit short-closed / $R \rightarrow 0 \Omega$)
ON	System Malfunction (circuit open / $R \rightarrow \infty \Omega$)

CHAPTER 27 - FLIGHT CONTROLS

27-00-00 Flight Controls

See [CHAPTER 67 – Rotors Flight Control](#).

Note: Stabilizers are described in [CHAPTER 55](#).

27-20-00 Flight Controls - Rudder

Rudder (Fin) and nose wheel are controlled simultaneously by adjustable foot pedals, control cables, central control link and nose wheel control link. Both pairs of pedals are interconnected and can be adjusted individually to suit different leg lengths. A shorter adjustment is achieved by pulling the handle which moves the pedals closer. Pulling the handle while pushing with both feet gently against the pedals allows longer adjustment.

In order to allow adjustment, the control cables are routed through teflon hoses which are fixated inside the 'S'-tube at the foot pedal. Outer and inner control cables are routed through/below the bottom shell using plastic cable lead-throughs (not shown). The pedal control cables of both pedal units are connected to the central control link. Rudder control is realized by push-pull control cables (not shown) which are connected to the central control link and are routed through bottom shell and keel tube. The schematic drawing shows pedals, control links, and the routing of the cables.

The tension of the control cables that connect central control link with nose wheel control link can be adjusted by turnbuckles. Adjust in a way that there is no freeplay or slack, but do not overtense! In case the tension of the control cables is suddenly low, check nose wheel control link.

The rudder fin is described in [55-40-00 Rudder](#).

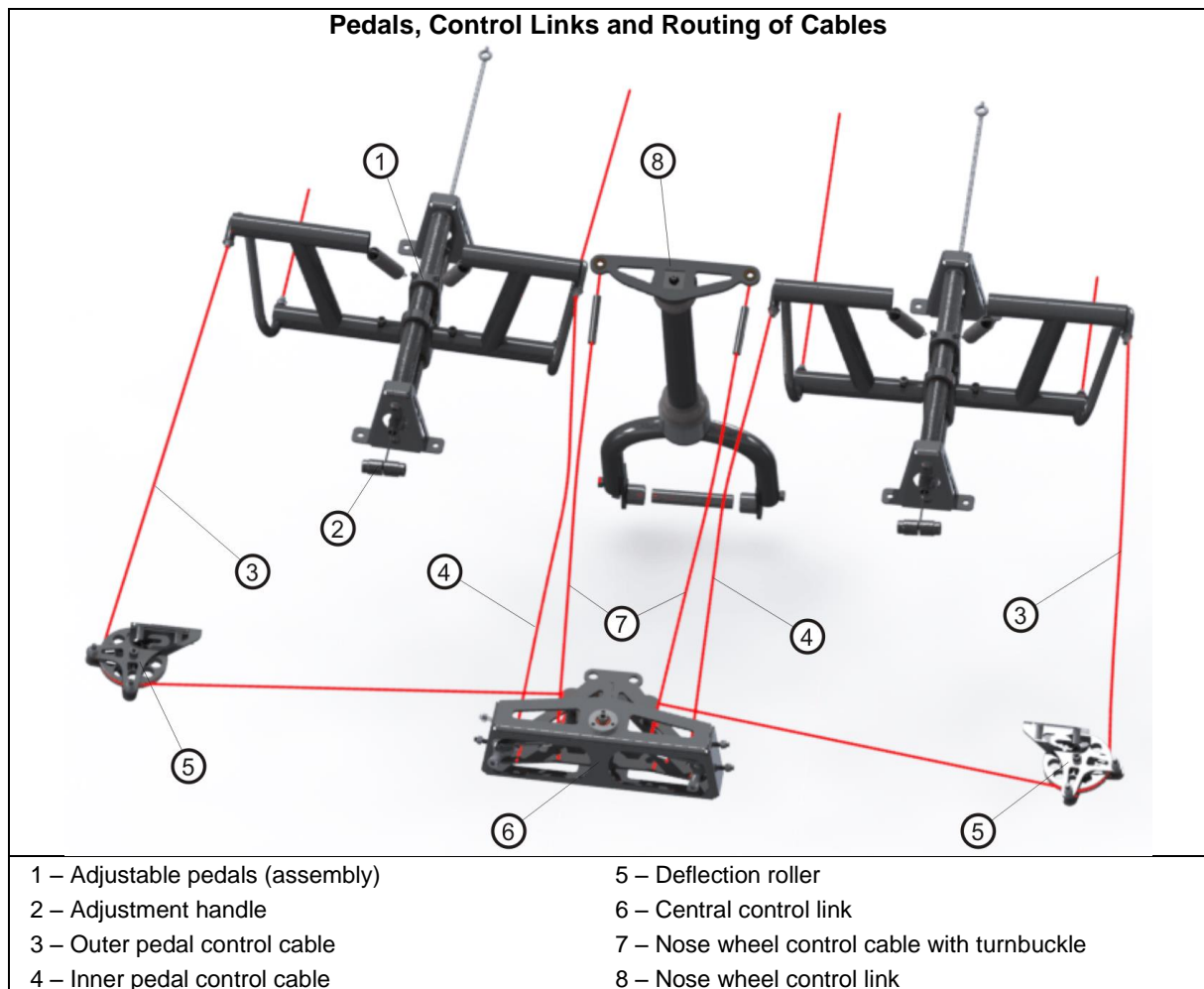

CHAPTER 28 - FUEL

28-10-00 Storage

The fuel system consists of two tanks permanently connected with a big crossport, a single filler port, fuel and ventilation lines, fuel level indications, and drain. The filler port is located at the left hand side of the gyroplane. In order to open the filler cap, lift, then turn the flap, and pull out. Reverse to close cap.

The tanks are installed behind the seats and have a capacity of 100 litres. Fuel level can be checked visually using a dip stick which has to be inserted diagonally from the fuel filler port.

Ventilation is provided by a vent line above the tanks leading through the mid channel directly to the outside.

28-20-00 Distribution

The fuel distribution system comprises fuel hoses, made of fabric-reinforced rubber, a shut-off valve, filters and pumps.

Possible fuel system versions differ with engine model, see schematics below. In case of ROTAX 914 engine variant, the fuel line with the second fuel pump P2 has a non-return valve to prevent flow-back when the second pump is switched off.

Fuel system ROTAX 912:

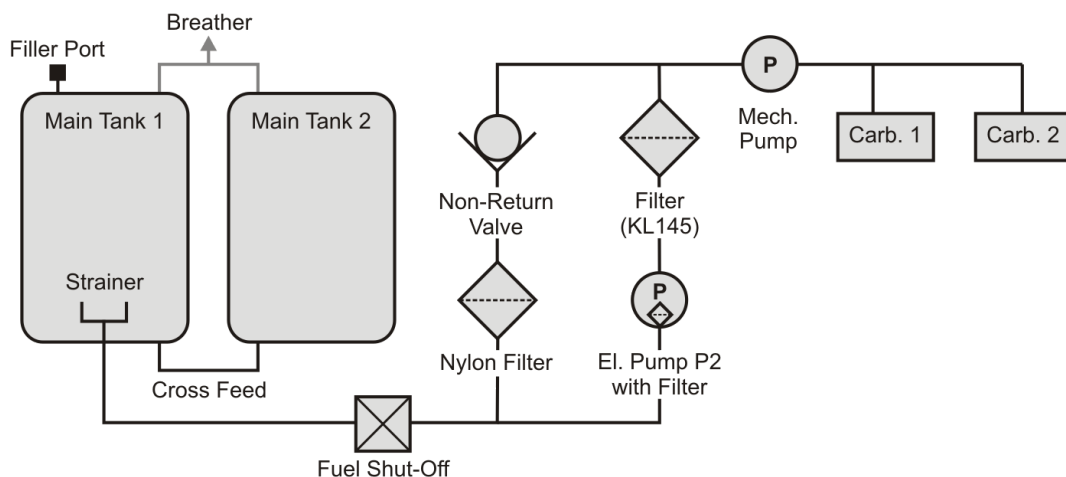

Fuel system ROTAX 914:

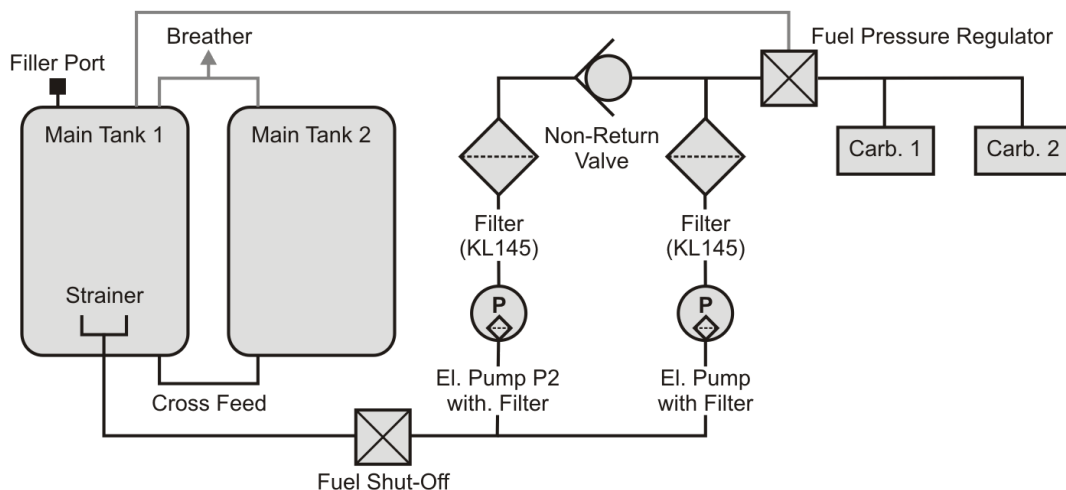

The safeguarded lever of the shut-off valve is located between the pilot and passenger seat below the intercom panel. The actual valve is located in the vicinity of the fuel tanks and is articulated by a torsion bar.

IMPORTANT NOTE: Fuel filters are Manufacturer Life Limited (MLL)!

28-40-00 Indicating

Fuel level can be checked visually using a dip stick which has to be inserted diagonally from the fuel filler port, and also by a fuel quantity indicator in the cockpit. Note that in both cases, fuel level is measured from the left hand tank only. Due to the large crossport the filling level of the second tank will be identical.

CHAPTER 29-30 - N/A

CHAPTER 31 – INDICATING SYSTEM

Note: The hour meter / HOBBS meter is described in [CHAPTER 77 - ENGINE INDICATING](#).

31-10-00 Instruments & Control Panels

Different instrument panel layouts are available. The basic instrumentation arrangements include:

- Standard Layout / Moving Map Portrait
- Glass Cockpit – Single Display
- Glass Cockpit – Dual Display

The standard layout includes all instruments necessary for flight but also installation provisions for additional conventional instrumentation.

The panel layouts Moving Map Landscape or Portrait include all relevant instruments arranged in a way to accept most off-the-shelf moving map navigation devices in the respective format. For detailed user information and instructions concerning the different moving map systems please refer to the manufacturer's documentation.

Depending on the chosen instrumentation and optional equipment, the depicted panels on the following pages may vary. Note that the standard or backup compass is mounted to the glare shield.

Panel Layout – Standard / Moving Map Portrait

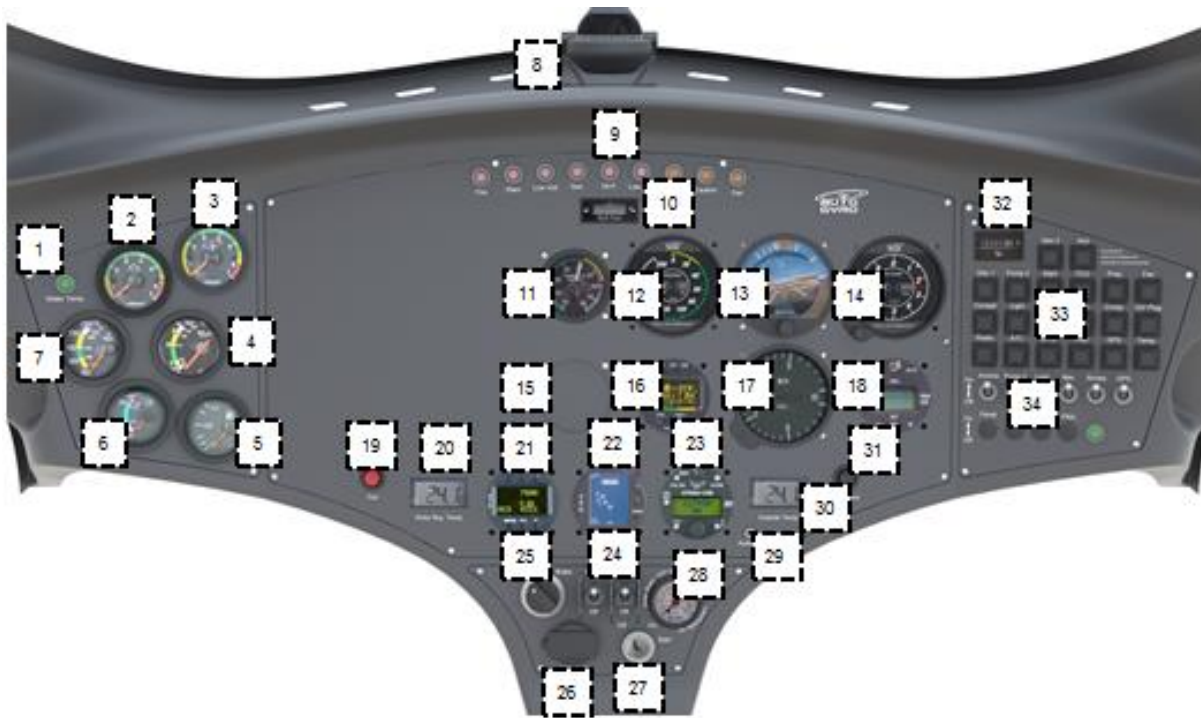

- | | |
|--|--|
| 1 – Water temperature indication | 20 – RBT indicator |
| 2 – Engine RPM | 21 – ATC transponder (if installed) |
| 3 – Rotor RPM | 22 – Collision Avoidance System (if inst.) |
| 4 – Oil pressure | 23 – Radio (if installed) |
| 5 – Fuel level indicator | 24 – MAG switches |
| 6 – Cylinder head temperature | 25 – Pneumatic mode selector |
| 7 – Oil temperature | 26 – 12V power receptacle (if installed) |
| 8 – Magnetic compass | 27 – Master/starter switch |
| 9 – Warning lights | 28 – Trim/brake pressure gauge |
| 10 – Lateral trim indicator | 29 – Audio in (if installed) |
| 11 – Manifold pressure gauge (if installed) | 30 – OAT indicator |
| 12 – Air speed indicator | 31 – Pre-rotator overdrive/override |
| 13 – Attitude Indicator (if installed) | 32 – Hour meter |
| 14 – Altimeter | 33 – Circuit Breaker Panel |
| 15 – Cut-out 57mm / 2 ¼" for optional inst. | 34 – Switches |
| 16 – Basic Flight Instrument (if installed) | |
| 17 – Vertical Speed Indicator (if installed) | |
| 18 – VPP control and end position detection IVO propeller (if installed) | |
| 19 – Cooling fan manual activation | |

31-60-00 Integrated Display Systems

The Glass Cockpit layout is tailored to the integrated flight and navigation suite DYNON AVIONICS SkyView. In addition to navigational and moving map functions, the system provides primary flight data and engine/vehicle monitoring. It is of utmost importance to read and understand the operators manual and to become familiar with the system before operation. In case of a system failure, a 2 ¼" (47mm) altimeter, air speed indicator and rotor speed indicator are provided as backup instrumentation.

Panel Layout – Glass Cockpit - Single Display



- | | |
|---|--|
| 1 – Water temperature indication | 15 – MAG switches |
| 2 – Magnetic compass | 16 – Trim/brake pressure gauge |
| 3 – Warning lights | 17 – 12V power receptacle (if installed) |
| 4 – Lateral trim indicator | 18 – Master/starter switch |
| 5 – Air speed indicator (back-up) | 19 – Audio in (if installed) |
| 6 – Altimeter (back-up) | 20 – Pre-rotator overdrive/override |
| 7 – Cut-out 57mm / 2 ¼" for optional inst. | 21 – Glass Cockpit |
| 8 – Vertical Speed Indicator (if installed) | 22 – Hour meter |
| 9 – Cooling fan manual activation | 23 – Circuit Breaker Panel |
| 10 – RBT indicator Switches (options) | 24 – Switches |
| 11 – ATC transponder (if installed) | |
| 12 – Collision Avoidance System (if inst.) | |
| 13 – Radio (if installed) | |
| 14 – Pneumatic mode selector | |

Panel Layout – Glass Cockpit - Dual Display



- | | |
|--|--|
| 1 – Water temperature indication | 13 – Pneumatic mode selector |
| 2 – Magnetic compass | 14 – 12V power receptacle (if installed) |
| 3 – Warning lights | 15 – Master/starter switch |
| 4 – Lateral trim indicator | 16 – Trim/brake pressure gauge |
| 5 – Air speed indicator | 17 – Audio in (if installed) OAT indicator |
| 6 – Altimeter | 18 – Pre-rotator overdrive/override |
| 7a – Glass Cockpit Display I | 19 – Hour meter |
| 7b – Glass Cockpit Display II | 20 – Circuit Breaker Panel |
| 8 – Cooling fan manual activation | 21 – Switches |
| 9 – ATC transponder (if installed) | |
| 10 – Collision Avoidance System (if inst.) | |
| 11 – Radio (if installed) | |
| 12 – MAG switches | |

CHAPTER 32 - LANDING GEAR

The Cavalon has a conventional tricycle gear with GRP (glass fibre reinforced plastic) suspension bow and a steerable nose gear.

32-10-00 Main Gear

The main gear consists of a GRP suspension bow which is bolted to the underside of the fuselage. The spar is designed to absorb even higher than normal landing loads in case of a hard landing or crash.

32-10-00 Nose Gear

The nose gear consists of a steerable nose wheel in a fork made of stainless steel (CrMo4) tubing with rubber damper (Manufacturer Life Limited!). Wheel and fork are covered by a wheel spat. Nose wheel steering is realized by a linkage to pedal/rudder control input using control cables.

32-40-00 Wheels and Brakes

Both main wheels feature hydraulic disc brakes. The hydraulic wheel brake is actuated by pulling the brake lever (2). A locking pawl mechanism allows setting for use as parking brake. In order to release the parking brake pull the brake lever a little further to let the spring-loaded locking pawl disengage, and then release wheel brake.

Do not try to disengage the locking pawl by pressing the small release lever without pulling the brake lever at the same time. Releasing the pawl using the small release lever only will lead to premature deterioration of the teeth. If the teeth are worn the function of the parking brake will be compromised!

The throttle and brake panel also supports the brake fluid reservoir with screw cap and fluid level min. and max. markings, as well as the primary brake cylinder (panel must be removed for access).

For correct tire pressure see [12-30-20 Servicing: Tire Pressure](#).

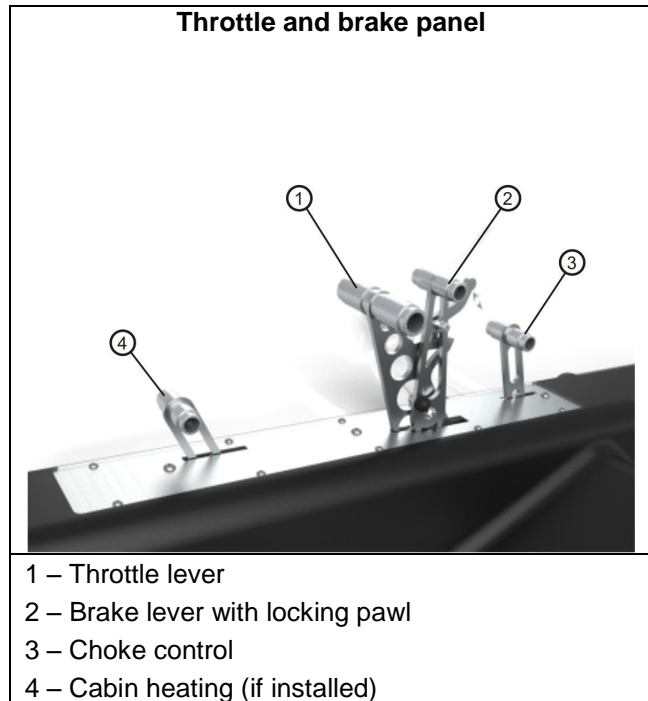

CHAPTER 33 - LIGHTS

33-40-00 Exterior

The aircraft is approved for day VFR operation only. As an option the following lights can be configured on the Cavalon:

- Landing Light
- Position Lights with integrated Strobe Lights

Electrical schematics / wiring diagrams are provided in [Part D - Diagrams and Charts](#) of this manual.

Power consumption figures are listed in [24-60-00 DC Electrical Load Distribution](#).

CHAPTER 34 - NAVIGATION

34-10-00 Flight Environment Data

The Cavalon features a Pitot-Static System to measure accurate air data. Total pressure is picked up by a pitot type tube located in the nose section of the fuselage. The tube is connected to the integrated cockpit instruments by a plastic line. The static pressure is measured across two ports, one on either side of the fuselage. OAT data is measured by a probe located at the bottom of the fuselage behind the nose gear and displayed in the cockpit as digital value.

34-20-00 Attitude and Direction

As part of minimum equipment, a magnetic compass is installed in the forward area below the windshield in pilot's sight. As an option, a vertical compass may be installed in the instrument panel.

34-70-00 ATC Transponder

An ATC Transponder may be installed as an option. Possible installation positions in the instrument panel are described in [CHAPTER 31](#). Please refer to the manufacturer's documentation for reference.

CHAPTER 35 - N/A

CHAPTER 36 - PNEUMATIC

Aircraft trim, rotor brake and activation of the pre-rotator is controlled by a pneumatic system, consisting of an electrically driven air compressor with filter/dryer, a pressure gauge in the cockpit and a pressure compensation vessel, solenoid valves, air lines, pneumatic actuators, and the respective cockpit controls.

The pneumatic system controls the following function:

- rotor brake ON, i.e. rotor disc flat / flight control stick forward position (brake mode)
- adjustable longitudinal trim, i.e. rotor disc/stick pulled aft (flight mode)
- engagement of the pre-rotator, i.e. activation of the clutch and upper engagement (only in flight mode or in brake mode with overdrive/override button)

The aforementioned functions are described in more detail in the dedicated chapters.

A schematic drawing of the pneumatic system is provided in [Part D - Diagrams and Charts](#) of this manual.

36-11-00 Generation / Compressor

The electrically driven compressor and filter/dryer is located at the rear wall on the lower RH side behind the removable fire wall. The wiring diagram is provided in [Part D - Diagrams and Charts](#) of this manual.

36-21-00 Distribution

Air distribution comprises of hoses, valves (solenoids), (cockpit) controls and switches, (pressure) sensors, filter/dryer and a pressure compensation vessel. The main pneumatic switching logic is combined in the pneumatic master box which is installed at the rear wall on the lower RH side behind the removable fire wall. See [Part D - Diagrams and Charts](#) for schematics.

Note that the pneumatics actuators (cylinders) are not described in this ATA Chapter, but assigned to their mechanical main function.

Example: the brake/trim cylinder is described in [67-05-00 Pitch Trim System / Rotor Brake](#).

CHAPTER 37-50 - UNASSIGNED / N/A

CHAPTER 51 - STANDARD PRACTICES - STRUCTURES

51-00-00 Standard Practices - Structures

Structural repair of composite structures or the welded steel frame is limited to AutoGyro GmbH or its specialized service partners (job cards labelled 'SPC').

CHAPTER 52 - DOORS, COVERS AND COWLINGS

52-10-00 Passenger / Crew

The gyroplane is embarked and disembarked from each side while the doors are held open by a gas spring. The gull-winged doors are hinged at the slanted door frame using two hinges with bolts and self-locking nut or alternatively quick release pins. Due to the slant angle the doors can be opened and closed in flight. The door locking mechanism is operated by moving an aluminium lever.

In order to close the door, pull the door close, move/lead the locking lever from 'Open' (aft position) to 'Close' (forward position) and let the lever snap sidewise into its locking detent. Do not pull by reaching through the open sliding window as this will cause the plexiglass to crack. Only use the dedicated grip/recess and operate locking lever with second hand while pulling door close.

Note that canopy windows are described in [56-15-00 Windows](#).

52-20-00 Emergency Exit

In case one of the doors is jammed or inaccessible, the opposite door is used as emergency exit.

52-40-00 Service Covers and Cowlings

In order to provide convenient access to engine, related components and other systems, service covers, cowlings and fairings must be removed. Location and procedures for removal/installation of service covers, cowlings and fairings are described in dedicated job cards in Part D of this manual.

CHAPTER 53 - FUSELAGE

The load carrying structure of the gyroplane consists of a composite monocoque occupant enclosure which is connected to the rotor tower and keel tube. The composite structure, composite tower and aft extension (keel tube) carries all loads induced by the crew stations, engine, rotor, undercarriage, stabilizer, and serves as installation platform for additional equipment. Attachment points for the engine installation are provided by a steel tube ring mount bolted to the rear of the monocoque enclosure.

The aft extension (keel tube) of the main frame is made of curved aluminium and carries the stabilizer. The keel tube is connected directly to mating counterparts of the monocoque structure by adhesive joint and secured by bolts. Two plastic protection pads are bolted to the underside of the aluminium tubing to protect the bow from abrasion in case of a tail slide (nose too high) during take-off, landing or wheel balance.

The protection pad must be inspected regularly and replaced as necessary in order to protect the aluminium tubing. In case the tubing is abraded, contact AutoGyro for assessment.

CHAPTER 54 - N/A

CHAPTER 55 - STABILIZERS

The stabilizer structure with rudder is made of GRP (or in certain cases CRP) and is bolted to the keel tube. Presence and function of the stabilizer plays a vital part in flight stability and safety. Inspect carefully all attachment points and the integrity of the composite component.

In order to assess the integrity of the stabilizer, carefully pull the fin tips in lateral direction (left/right) with a maximum of 150 N. A 'linear' resistance must be felt. In case mechanical noises are heard/felt, contact AutoGyro.

55-40-00 Rudder

The rudder is made of GRP and is hinged to the central fin of stabilizer. An aluminium trim tab is provided to eliminate constant pedal input during cruise flight and to provide a pre-defined rudder setting in case of a control failure. The trim tab should be adjusted to allow pedal-off cruise flight. Adjust according to the following table:

Pedal input (for straight and level flight, slip indic./ball centred)	Corrective action (seen from behind, i.e. in flight direction)
Constant right pedal required	Bend trim tab to the left
Constant left pedal required	Bend trim tab to the right

Avoid unnecessary bending as the tab may break at its perforation. A misadjusted or broken tab may change flight characteristics significantly and in case of a rudder control failure, the gyroplane may render difficult to control. Replace trim tab if it feels soft or if fissures at the perforated part are visible.

CHAPTER 56 - WINDOWS

56-10-00 Flight Compartment / Canopy

Outside visibility and environmental protection for pilot and occupant is provided by one large undivided front window and a window in each door. The windows are made of formed Plexiglas which is sealed into the door frame.

56-15-00 Canopy Windows

Each door window features an open/closable and adjustable fresh air vent and one sliding window with pivoting vent for ventilation.

CHAPTER 57-60 - UNASSIGNED / N/A

CHAPTER 61 - PROPELLER

In standard configuration a 3-bladed, fixed pitch propeller with GRP propeller blades is installed. Depending on customer configuration a spinner may be installed! As an option, a variable pitch propeller may be available (country specific).

Adjustment of the fixed pitch propeller is described in a dedicated Job Card in Part E of this manual. The mechanical end stops of the variable pitch propeller are pre-adjusted by AutoGyro. In case, re-adjustment should be necessary on the variable pitch propeller, please refer to the manufacturer's documentation or contact AutoGyro.

In certain cases, damaged propeller blades can be repaired (specialized / SPC maintenance task). Concerning repair limits and allowable damage contact AutoGyro GmbH. Provide a precise description of the damage, dimensions and preferably photos of the affected area.

61-10-00 Propeller assembly

The propeller assembly comprises propeller blades, hub and related attachment hardware.

61-20-00 Controlling

In case of a variable pitch propeller (VPP) refer to the manufacturer's (IVO) documentation and respective wiring diagrams in Part D of this manual.

CHAPTER 62 - ROTOR

The two-bladed, semi-rigid, teetering rotor system comprises high-strength aluminium extruded rotor blades, a hub bar, and a common teeter hinge assembly.

Due to their working principle, every two-bladed teetering rotor system induces a certain amount of vibration, depending on flight condition (speed) and disc loading. AutoGyro optimizes each rotor system at a medium disc loading and speed before delivery. However, if the rotor system shall be tuned to a different flight condition or reveals undue vibration, contact AutoGyro or a specialized service partners (maintenance level 'S').

IMPORTANT NOTE: Rotor Systems are Manufacturer Life Limited (MLL)!

Some guidelines to Vibration and Noise Analysis and classification schemes are provided in [CHAPTER 18](#) (Part B) of this manual.

62-11-00 Rotor – Teetering Parts

The teetering parts of the rotor system consist of teeter bolt, teeter block, rotor hub (bar), and rotor blades. The rotor blades feature an aerodynamic profile especially suitable for rotorcraft which, in combination with its relative centre of gravity, provides aerodynamic stability by eliminating negative blade pitching moments and flutter tendency. The hollow blade profile is sealed at both ends by plastic blade caps.

The aluminium rotor hub bar is pre-coned to the natural coning angle of the blades and connects the blades firmly to each side using 6 fitting bolts and a clamping profile. In order to compensate for asymmetric air flow in forward flight the blades are free to teeter. The hinge assembly consists of teeter tower, teeter bolt and teeter block.

The teeter bolt runs in a long Teflon coated bushing in the teeter block (main bearing action), as well as two shorter bushings in the teeter tower (emergency bearing action). The main bearing action is supported by special grease which is applied through a grease nipple on top of the teeter block. Servicing is described in [CHAPTER 05](#) (Part B) of this manual.

62-31-00 Rotor Head Bridge, Bearing and Teeter Tower

The rotor head bridge is made of welded stainless steel. Rotor bearing (Manufacturer Life Limited!) and teeter tower represent one integrated component. The rotor bearing temperature (RBT) sensor is also allocated to the rotor head bridge, respectively the rotor bearing.

62-32-00 Rotor Gimbal Head

Tilting action or rotor flight control of the rotor is facilitated by the rotor gimbal head. The gimbal head is sometimes also referred to as 'hang point' and represents a cardan hinge.

62-41-00 Rotor RPM Monitoring

Rotor RPM monitoring is realized by an inductive pick-up which is installed with a gap of 3-4 mm at the sprocket wheel. The sensor counts the (10) holes in the sprocket disc. Rotor RPM is indicated in the cockpit in an analogue -type instrument which also houses the control electronic. The system requires power supply.

62-51-00 Rotor Vibration Isolation

A certain level of vibration is inherent to any 2-bladed rotor system. In order to reduce vibration levels to a minimum, a vibration decoupling element in the rotor mast isolates rotor vibration from the fuselage. Vibration isolation is realized by two mast mounting bushings which connect the split mast.

IMPORTANT NOTE: Mast mounting bushings are Manufacturer Life Limited (MLL)!

CHAPTER 63 - ROTOR DRIVE

63-11-00 Pre-rotator

The pre-rotator is used to quickly bring the rotor up to safe RPM for take-off run by the press of a button. Pre-rotation is activated by a push-button on the flight control stick. Because of a safety circuit, activation of the pre-rotator is only possible with the pneumatic mode selector in FLIGHT position and the control stick fully forward. This prevents inadvertent activation of the pre-rotator during flight or in BRAKE mode.

The pre-rotator is activated as long as the respective push-button on the control stick head is depressed, provided the following pre-conditions are met:

- pneumatic mode selector set to FLIGHT
- control stick in full forward position
- trim pressure less than 3 bar

In this case, the pneumatic clutch is activated and engine torque is transmitted through a 90° gearbox and drive to the pinion which is engaged by another small pneumatic actuator into the geared ring / sprocket wheel of the rotor head. The drive pinion is sliding on a helical gear to provide automatic lock-out in case of rotor RPM overrun. In order to allow necessary changes in length the vertical pre-rotator drive shaft features a sliding sleeve coupling.

NOTE: In order to simplify pre-rotation AutoGyro GmbH has developed a new 90-degree-gearbox with a transmission ratio specially geared to the Cavalon. The new gearbox is factory installed from serial numbers (Werk-Nr.) V00036 on, or may be retrofitted as a unit together with the pneumatic clutch.

The modified transmission ratio allows simpler handling during pre-rotation using a slightly increased clutch speed. The configuration state pneumatic clutch III (new 90-degree-gearbox) is easily discernible by having a black OVERDRIVE push button instead of a red one.

Pneumatic clutches / gearboxes shall be retrofitted to configuration state III.

The pre-rotator can be activated in BRAKE position to park the rotor blades fore-aft for taxi. To do so, the pre-rotator push-button and the overdrive/override switch in the cockpit panel have to be pressed simultaneously. Prolonged activation of the pre-rotator with rotor brake engaged should be avoided.

63-11-10 Pre-rotator Lower Engagement

Pre-rotator lower engagement consists of the pneumatically activated clutch.
For pneumatic control of the clutch refer to [CHAPTER 36 - PNEUMATIC](#).

63-11-20 Pre-rotator Drive

Power flow is realized through a 90-degree gearbox and drive shafts. The 90-degree gearbox is mounted directly to the disc clutch. The pre-rotator drive shaft features a cardan joint right after the 90-degree gearbox and a sliding shaft coupling in the upper area to allow changes in length due to the tilt of the rotor head.

63-11-30 Pre-rotator Upper Engagement

The pre-rotator upper engagement comprises a drive pinion with bearing, which is engaged by a small pneumatic actuator into the geared ring / sprocket wheel of the rotor head. The drive pinion is sliding on a helical gear to provide automatic lock-out in case of rotor RPM overrun.

63-51-00 Rotor Brake System

The rotor brake system consists of a brake pad mounted to a bracket which is hinged to the rotor head bridge. With the pneumatic mode selector in BRAKE position the operation of the pneumatic trim actuator is reversed so that increased pressure causes the actuator to push the rotor head up (or level) and presses a brake pad against the rotor head disc. In order to increase brake pressure, move the 4-way trim switch to aft. Note that this action will also push the control stick forward. At full brake pressure the control stick will be maintained in its full forward position.

Due to its main function the pneumatic brake/trim actuator/cylinder itself is allocated to [67-05-00 Pitch Trim](#).

CHAPTER 64-66 - N/A

CHAPTER 67 - ROTOR FLIGHT CONTROL

Rotor flight control comprises of control stick, a control tube running horizontally along the bottom of the fuselage, and push-pull control cables (Manufacturer Life Limited!) which are routed vertically along the mast and connected to the rotor head bridge.

Pitch and roll of the gyroplane is controlled by tilting the complete rotor head by means of the control stick. Control input is transferred via torsion tube and linkage running below the seats to the base link and from there to the rotor head via push-pull control cables.

The control stick head is ergonomically shaped to fit the pilot's right hand and features control buttons for radio transmission (1), a four-way trim function (2), and activation of the pre-rotator (3).

67-05-00 Pitch Trim System / Rotor Brake

The Pitch Trim System comprises of a 4-way beep trim switch (2) / "Chinese Hat" at the flight control stick and the pitch trim / brake pneumatic actuator. Pneumatic control is allocated to and described in [CHAPTER 36](#). Components related to the rotor brake are allocated to [63-51-00 Rotor Brake System](#).



Trimming is effected by varying trim pressure in the pneumatic trim actuator which is installed in parallel with the rotor head tilt for pitch control. Aft or nose-up trimming activates the electrical compressor and increases trim pressure, causing the actuator to contract, and tilting the rotor disc aft. Forward trimming opens the pressure relief valve to reduce trim pressure and allows the rotor disc to flatten, due to the spindle head offset and the gyroplane's weight. The actual trim condition is indicated on the trim/brake pressure gauge in the centre panel of the cockpit.

67-06-00 Roll Trim System

Lateral/roll trim is available as an option and works accordingly, using a lateral pneumatic trim cylinder installed in addition. With this option installed, lateral trim condition is indicated by a LED bar on the instrument panel.

CHAPTER 68-70 - UNASSIGNED / N/A

CHAPTER 71 - POWER PLANT

Power plant comprises aircraft provisions, installations and systems related to the core engine. The engine itself is allocated to [CHAPTER 72 – 74](#).

71-10-00 Engine Cowling

Concerning engine cowlings see [CHAPTER 52 - DOORS, COVERS AND COWLINGS](#).

71-20-00 Engine Mounts

Attachment points for the engine installation are provided by a steel tube ring mount at the rear of the mast. To provide vibration isolation, the engine is connected to the ring frame by 4 rubber mounting bushings. The engine mounting bushings have to be inspected regularly and have to be replaced, if torn or porous. Defective rubber bushing can also cause undue engine/propeller vibration.

IMPORTANT NOTE: Engine mounting bushings are Manuf. Life Limited (MLL)!

71-30-00 Engine Firewalls

An engine fire wall, installed at the rear end of the monocoque fuselage, isolates the engine compartment from equipment installed at the rear wall, fuel tanks and passenger cabin. The engine fire wall consists of a fixed part (inner part) and a removable part which is shaped like a 'u' around the fixed part and overlap with the latter. The removable part actually consists of two parts joint by connecting bolts which, in most cases, do not need to be separated at removal or installation.

71-50-00 Engine Electrical Harness

The engine electrical harness includes wiring, cables and cockpit switches for starting, energizing and grounding of the dual breakerless capacitor discharge ignition circuits (including instructor killing switches, if installed), and engine indication. A wiring diagram is provided in Part D of this manual. Also refer to the engine manufacturer's documentation.

71-60-00 Engine Air Intakes

A central engine air intake for cooling and aspiration is provided as ram air inlet in the lower area forward mast cover, just above the cabin. The engine aspirates air from the engine air intake through air filters mounted on each of the carburettors.

71-70-00 Engine Drains

Oil tank breathing is provided by a rubber hose that exits through lower engine cowling to the outside.

CHAPTER 72 TO 74 - ENGINE RELATED

For the (core) engine refer to the engine manufacturer's documentation in its latest revision.

Concerning fuel system (Filter, Pumps, Shut-off valve) see [CHAPTER 28](#).

Engine cowlings are described in [CHAPTER 52](#). For removal and installation see the dedicated Job Card in Part E of this manual.

CHAPTER 75 - AIR / ENGINE COOLING

Engine cooling is provided by ram air cooled cylinders and liquid cooled cylinder heads. Therefore, cylinder head temperature (CHT) indication in the cockpit corresponds to water temperature. Sufficient cooling air flow is provided by a ram air duct in the lower portion of the forward mast cover. The water cooling system comprises of engine driven pump, radiator with thermo-activated electrical blower fan, expansion tank / overflow bottle with radiator cap, and hoses.

NOTE: The expansion tank / overflow bottle is located in the ram air duct in the lower portion of the forward mast cover.

A single, large area radiator is mounted above the engine so that cooling air from the ram air duct passes through the cooler, is directed around the engine's cylinders, and finally escapes through gills at the lower engine cowling. Force cooling is ensured by an electrically driven ducted fan controlled by a thermo switch. A push-button in the cockpit allows manual activation temporarily which is typically used to avoid possible heat build-up after shut-down.

For the relevant checking and replenishing procedures, refer to engine manufacturer's manual.

Oil cooling is described in [CHAPTER 79](#).

CHAPTER 76 - ENGINE CONTROLS

Engine control consists of engine power lever / throttle with choke and related cockpit switches for engine shut-down and test.

76-10-00 Power Control / Choke

Engine power / throttle is controlled by a control column installed in the centre console between the crew seats. The unit combines a choke control (3) as well as a lever for activation of the wheel brake.

Throttle control (1) is conventional with IDLE in aft (or pulled) and full throttle in most forward position. With the ROTAX 914 UL engine the boost range is entered by overcoming a small resistance to the front. The throttle lever is linked with cable controls to the carburettors. A mechanical spring applies tension to the control cables and brings the carburettors to full throttle in case of a cable break. The throttle lever has a pre-set friction brake which holds the throttle in the selected position.

Choke (3) is used start a cold engine. In order to do so, pull the choke lever fully to the rear or ON position and be sure to have the throttle in idle position. After starting the engine and a short warm-up, the choke can be slowly disengaged by moving the lever into its forward or OFF position.

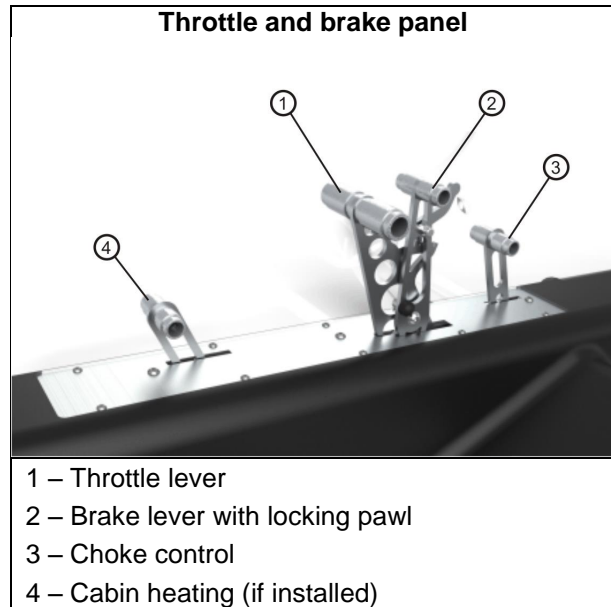

76-20-00 Engine Shutdown / Emergency

For normal and emergency shutdown, a pair of magneto switches (MAG 1 + MAG 2) is installed in the cockpit centre panel. The magneto switches are also used for testing the individual ignition circuits. The switches are protected against inadvertent operation by sheet metal safety plates.

CHAPTER 77 - ENGINE INDICATING

All relevant engine parameters are displayed in the cockpit, using analogue-type instruments in standard version. In case of integrated cockpit systems (option), engine data may be displayed in the integrated instrumentation system (glass cockpit). An hour meter (Hobbs Meter) is installed in the cockpit to count engine operating time with an accuracy of two decimals (1/100 hrs). Although the 'engine operating time' is also used for total aircraft hours counting, the hour meter is allocated to this chapter as the main function.

77-10-00 Power

With a piston engine with fixed pitch propeller, engine power indication solely consists of an engine RPM indicator. In case a variable pitch propeller is installed, a manifold absolute pressure (MAP) indicator is provided in addition. See [CHAPTER 31](#) for different cockpit layouts.

77-20-00 Temperature

For temperature indication, a cylinder head temperature (CHT) gauge is provided. Due to the engine cooling principle (ram-air cooled cylinders with water cooled cylinder heads) the CHT represents water temperature at cylinder 2 head.

Oil temperature indication is described in [CHAPTER 79 – OIL SYSTEM](#).

77-40-00 Integrated Engine Instrument Systems

Integrated display systems (glass cockpit) are described in [31-60-00 Integrated Display Systems](#).

CHAPTER 78 - EXHAUST

78-00-00 Exhaust

The basic exhaust system including manifold and turbo charger with waste gate (only ROTAX 914) is part of the core engine. Refer to the engine manufacturer's documentation. The exhaust system is supplemented by a silencer/muffler supplied by AutoGyro.

CHAPTER 79 - OIL SYSTEM

The dry sump forced lubrication comprises oil pump, separate oil tank with dip stick, oil cooler, hoses, as well as oil temperature and oil pressure indication.

79-11-00 Storage / Oil tank

The oil reservoir with dipstick is accessed through a cover on the right hand side of the fuselage. The cover is held by 3 cam lock fasteners which can be locked or unlocked by a quarter turn. The oil tank is made of stainless steel with oil filler cap. The cap can be unscrewed / tightened by a quarter rotation in order to check the oil level using a dip stick or for replenishing of engine oil.

The type of lubrication system requires a special procedure for accurate oil level checking and to prevent overfilling. Refer to the engine manufacturer documentation for detail and procedures.

79-20-00 Distribution and Cooling

Oil distribution and cooling is provided by a separate oil cooler, which is connected to the oil circuit by oil hoses and a thermostat assembly.

79-21-00 Oil Hoses and Lines

Oil hoses are made of fabric reinforced rubber, or steel braided lines in later versions.

79-22-00 Oil Cooler

An oil cooler is fitted to the lower aft end of the fuselage. Oil flow through the cooler is regulated by a thermostat assembly which opens the cooler circuit at approximately 80 – 90 °C

79-30-00 Indicating

Indicators of Oil Pressure (Oil-P) and Oil Temperature (Oil-T) are provided in the cockpit as analogue-type instruments in standard version. See [CHAPTER 31](#) for different cockpit layouts.

Contents

Wiring Diagram – Aircraft Main Wiring Harness.....	3
Wiring Diagram – Cockpit RH.....	5
Wiring Diagram – Optional Comfort Features Seats.....	7
Wiring Diagram – Flight Control Sticks.....	9
Wiring Diagram – Landing Lights.....	11
Wiring Diagram – NAV / Strobe Lights.....	13
Wiring Diagram – Cockpit LH (Standard).....	15
Wiring Diagram – Main Fuse / Battery.....	17
Wiring Diagram – Cockpit Centre.....	19
Wiring Diagram – Cockpit (General).....	21
Wiring Diagram – Pneumatic System (Standard / Comfort).....	23
Wiring Diagram – Fuel Pumps.....	25
Wiring Diagram – Fuel Level and Low Level Sensors.....	27
Wiring Diagram – Engine Wiring Harness.....	29
Wiring Diagram – Engine Turbo Control Unit (TCU) Wiring Harness.....	31
Pneumatic Scheme - Standard.....	33
Pneumatic Scheme - Comfort.....	35
Retrofit: End Position Detection IVO Propeller.....	37

INTENTIONALLY LEFT BLANK

Wiring Diagram – Aircraft Main Wiring Harness

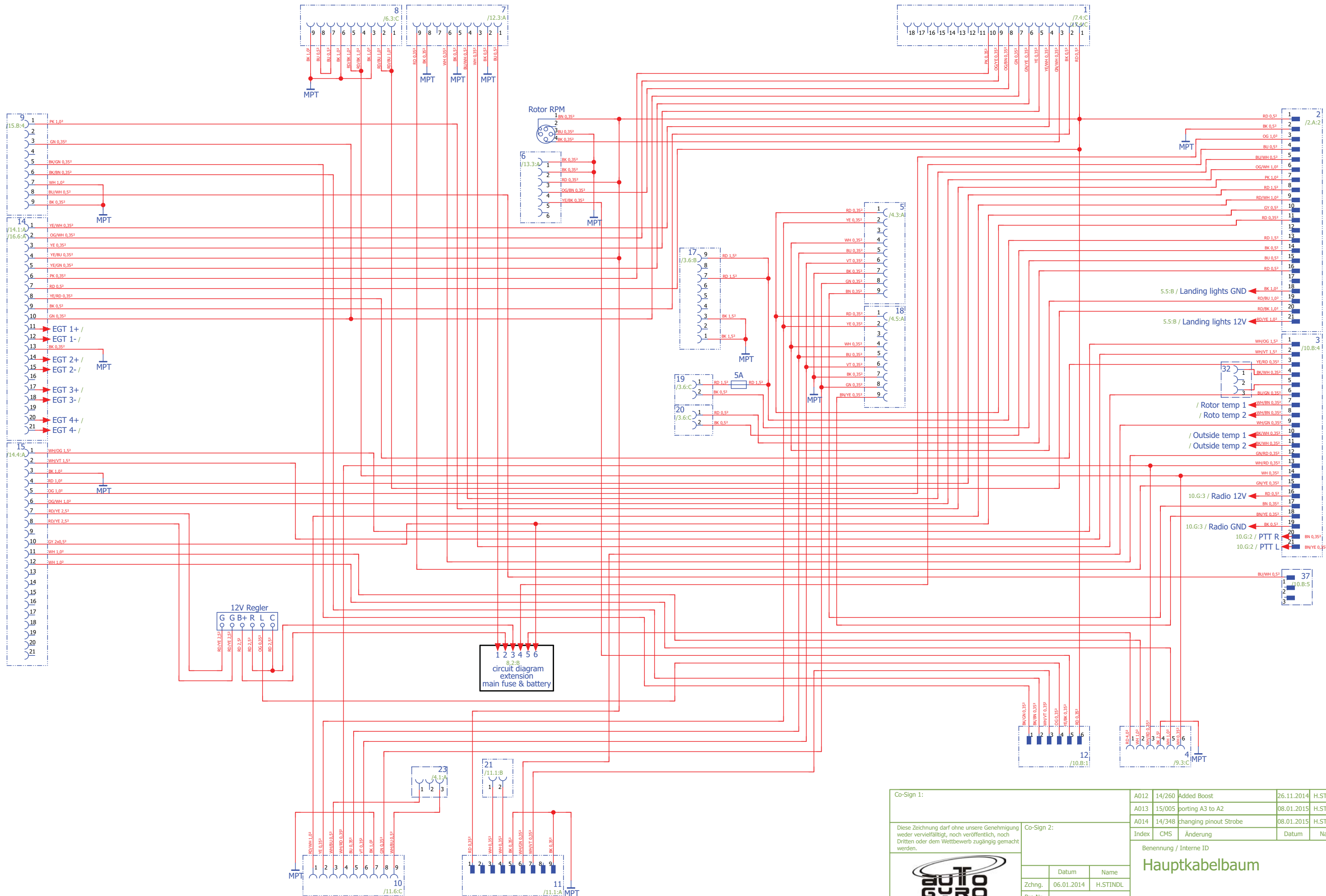

Co-Sign 1:		A012	14/260	Added Boost	26.11.2014	H.STINDL																			
Co-Sign 2:		A013	15/005	porting A3 to A2	08.01.2015	H.STINDL																			
Diese Zeichnung darf ohne unsere Genehmigung weder vervielfältigt, noch veröffentlicht, noch Dritten oder dem Wettbewerb zugänglich gemacht werden.		A014	14/348	changing pinout Strobe	08.01.2015	H.STINDL																			
 <p>RotorSport UK Ltd Unrivaled Sport Gyroplanes</p>		Index	CMS	Änderung	Datum	Name																			
<table border="1"> <tr> <th colspan="2">Benennung / Interne ID</th> </tr> <tr> <td colspan="2">Hauptkabelbaum</td> </tr> <tr> <th colspan="2">Revision</th> </tr> <tr> <td colspan="2">BG1908</td> </tr> <tr> <td colspan="2">A014</td> </tr> </table>		Benennung / Interne ID		Hauptkabelbaum		Revision		BG1908		A014		<table border="1"> <tr> <th>Datum</th> <th>Name</th> </tr> <tr> <td>06.01.2014</td> <td>H.STINDL</td> </tr> <tr> <th>Pro.Nr.</th> <td></td> </tr> <tr> <td></td> <td>A2</td> </tr> <tr> <th>Blatt:</th> <td>1 von 17</td> </tr> </table>				Datum	Name	06.01.2014	H.STINDL	Pro.Nr.			A2	Blatt:	1 von 17
Benennung / Interne ID																									
Hauptkabelbaum																									
Revision																									
BG1908																									
A014																									
Datum	Name																								
06.01.2014	H.STINDL																								
Pro.Nr.																									
	A2																								
Blatt:	1 von 17																								

Wiring Diagram – Cockpit RH

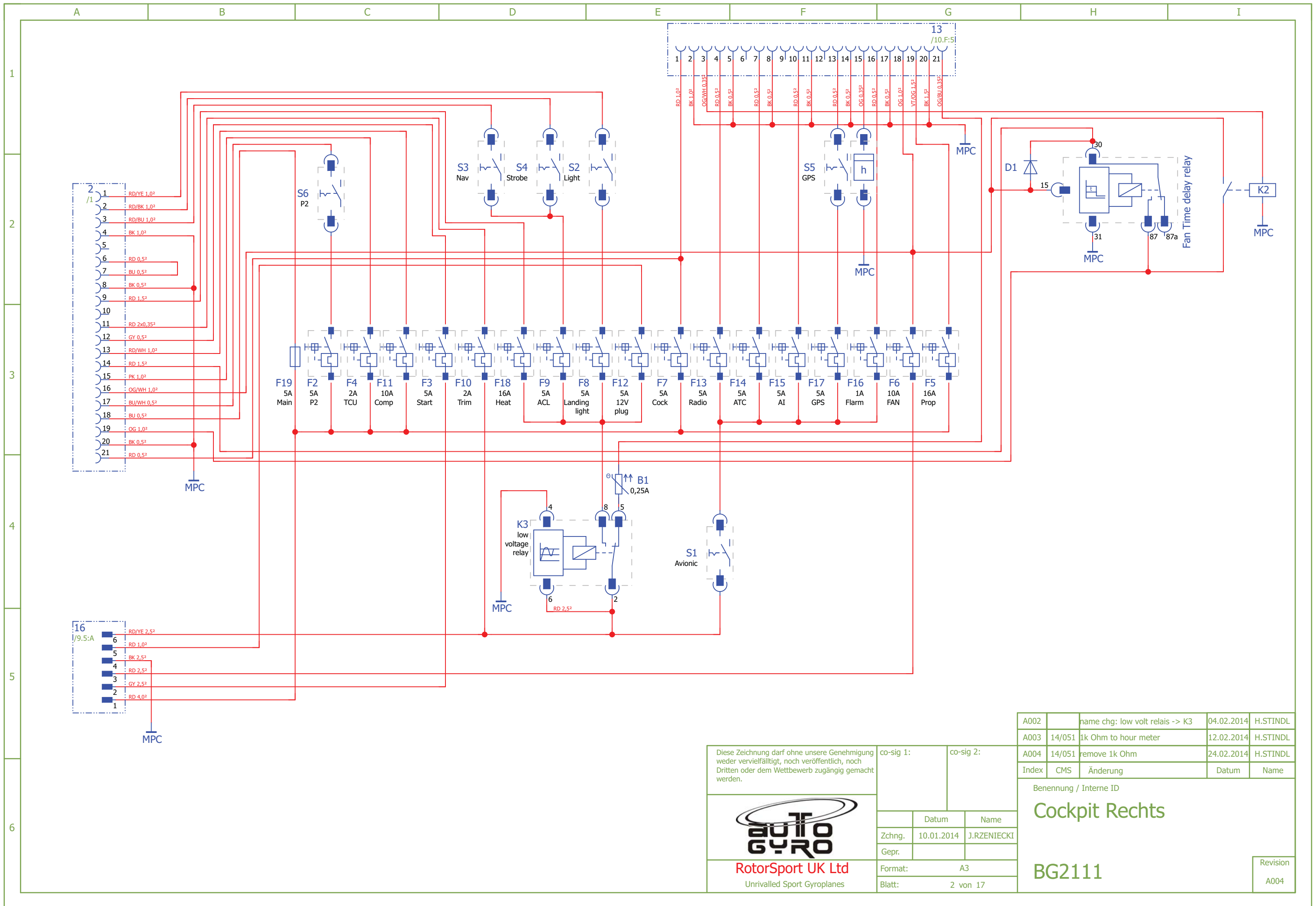

A002		name chg: low volt relais -> K3	04.02.2014	H.STINDL
A003	14/051	1k Ohm to hour meter	12.02.2014	H.STINDL
A004	14/051	remove 1k Ohm	24.02.2014	H.STINDL
Index	CMS	Änderung	Datum	Name

Benennung / Interne ID

Cockpit Rechts

BG2111

Revision
A004

Diese Zeichnung darf ohne unsere Genehmigung weder vervielfältigt, noch veröffentlicht, noch Dritten oder dem Wettbewerb zugänglich gemacht werden.

co-sig 1:

co-sig 2:



RotorSport UK Ltd
Unrivalled Sport Gyroplanes

	Datum	Name
Zchng.	10.01.2014	J.RZENIECKI
Gepr.		
Format:	A3	
Blatt:	2 von 17	

Wiring Diagram – Optional Comfort Features Seats

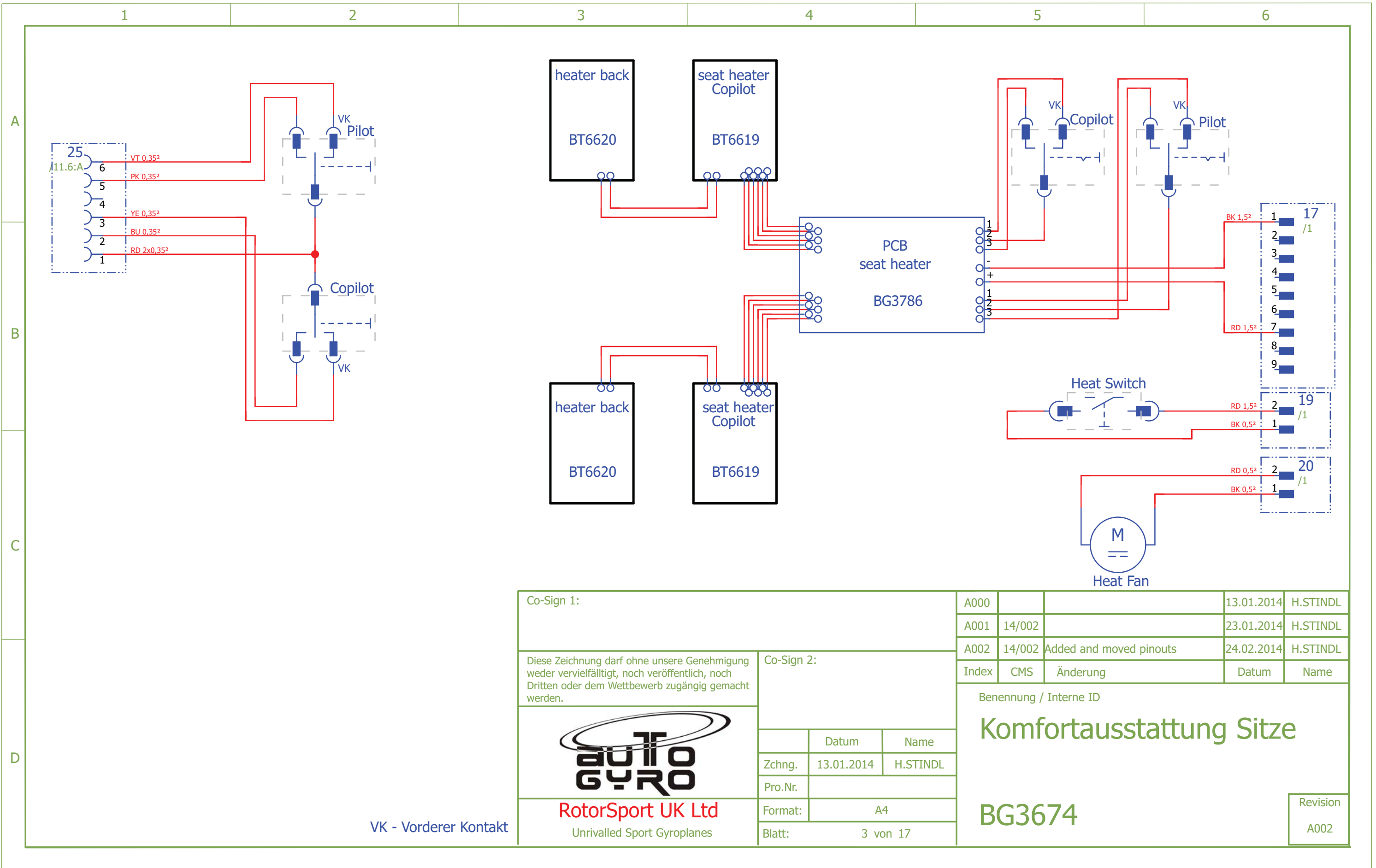

Co-Sign 1:		A000		13.01.2014	H.STINDL
		A001	14/002	23.01.2014	H.STINDL
		A002	14/002	24.02.2014	H.STINDL
Diese Zeichnung darf ohne unsere Genehmigung weder vervielfältigt, noch veröffentlicht, noch Dritten oder dem Wettbewerb zugänglich gemacht werden.		Co-Sign 2:		Index	CMS
				Änderung	
				Datum	
		Zchnng.	13.01.2014	Name	
		Pro.Nr.			
		Format:	A4		
		Blatt:	3 von 17		
		Benennung / Interne ID			
		Komfortausstattung Sitze			
		BG3674			
		Revision			
		A002			

VK - Vorderer Kontakt

RotorSport UK Ltd
Unrivalled Sport Gyroplanes

Wiring Diagram – Flight Control Sticks

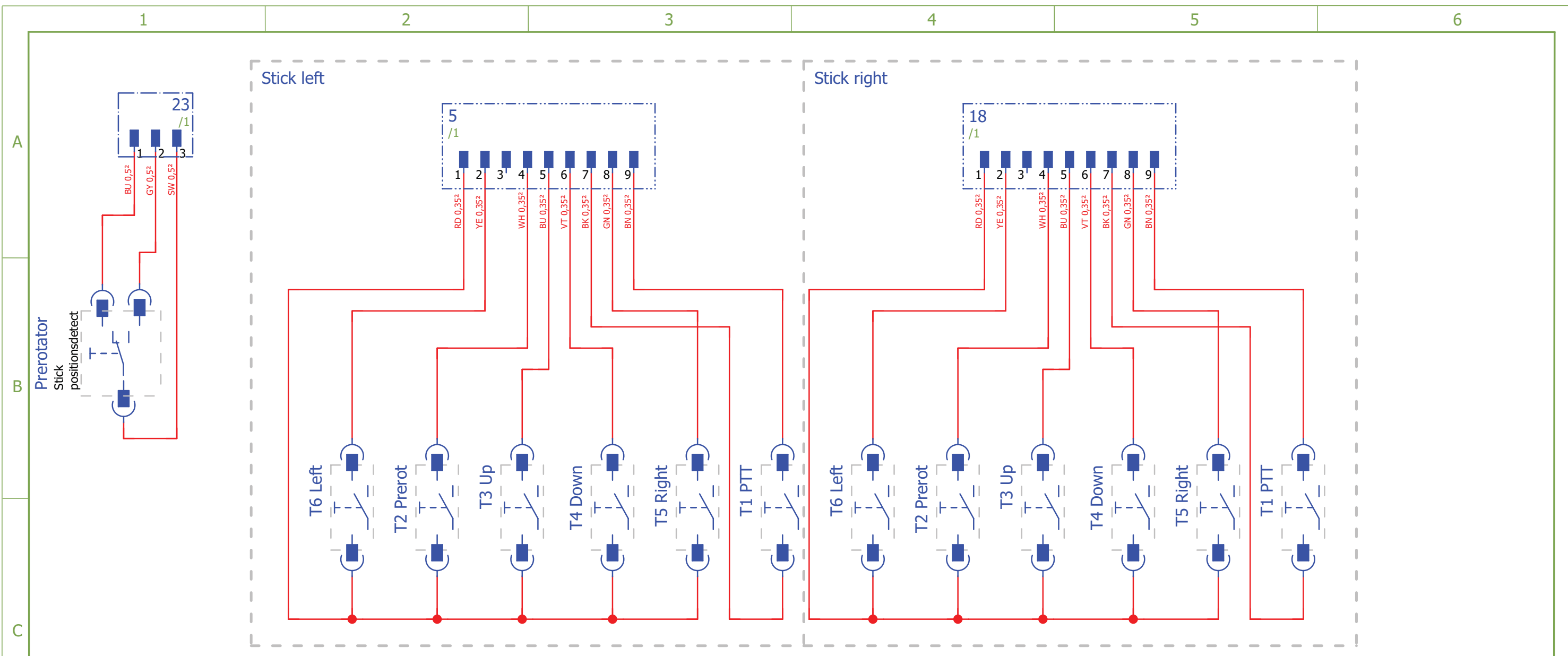

Co-Sign 1:		A002	14/002	Added pinouts	24.02.2014	H.STINDL
		A003	14/078	Changed plug 23	25.02.2014	H.STINDL
		A004	14/078	Changed plug to socket (23)	25.02.2014	H.STINDL
		Index	CMS	Änderung	Datum	Name
		Benennung / Interne ID				
		Sticks				
		BG3265				
		Revision				
		A004				

Diese Zeichnung darf ohne unsere Genehmigung weder vervielfältigt, noch veröffentlicht, noch Dritten oder dem Wettbewerb zugänglich gemacht werden.



RotorSport UK Ltd
Unrivalled Sport Gyroplanes

Co-Sign 2:		
	Datum	Name
Zchnng.	14.01.2014	H.STINDL
Pro.Nr.		
Format:	A4	
Blatt:	4 von 17	

Wiring Diagram – Landing Lights

1 2 3 4 5 6

A

B

C

D

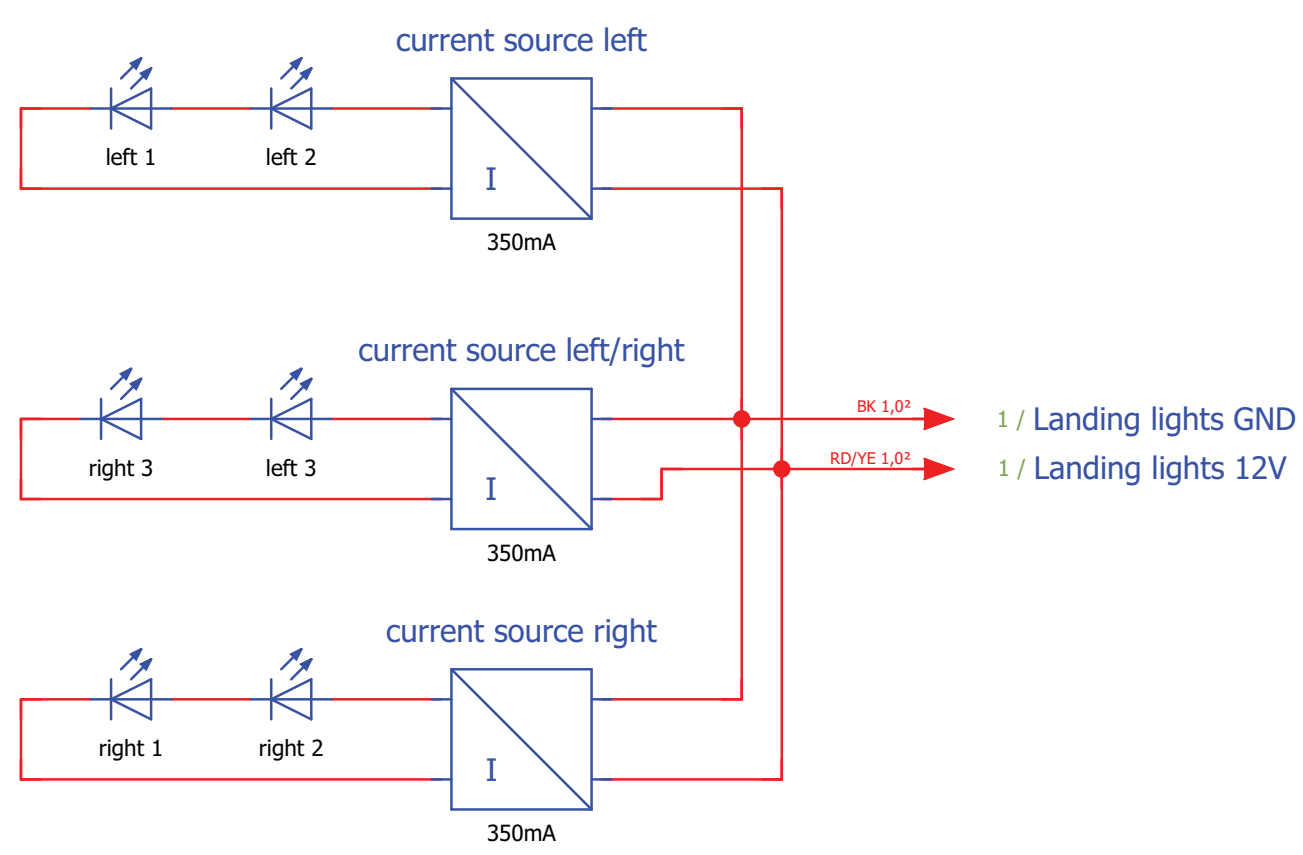

Co-Sign 1:		A001	14/002		23.01.2014	H.STINDL
		A002	14/301	change wiring	26.11.2014	H.STINDL
		A003	14/301	change labeling	07.01.2015	H.STINDL
		Index	CMS	Änderung	Datum	Name
Diese Zeichnung darf ohne unsere Genehmigung weder vervielfältigt, noch veröffentlicht, noch Dritten oder dem Wettbewerb zugänglich gemacht werden.		Co-Sign 2:				
 RotorSport UK Ltd Unrivalled Sport Gyroplanes			Datum	Name	Benennung / Interne ID <h1>Landescheinwerfer</h1> <h2>BG2150</h2>	
		Zchnng.	14.01.2014	H.STINDL		
		Pro.Nr.				
		Format:	A4			
		Blatt:	5 von 17			
						Revision A003

Wiring Diagram – NAV / Strobe Lights

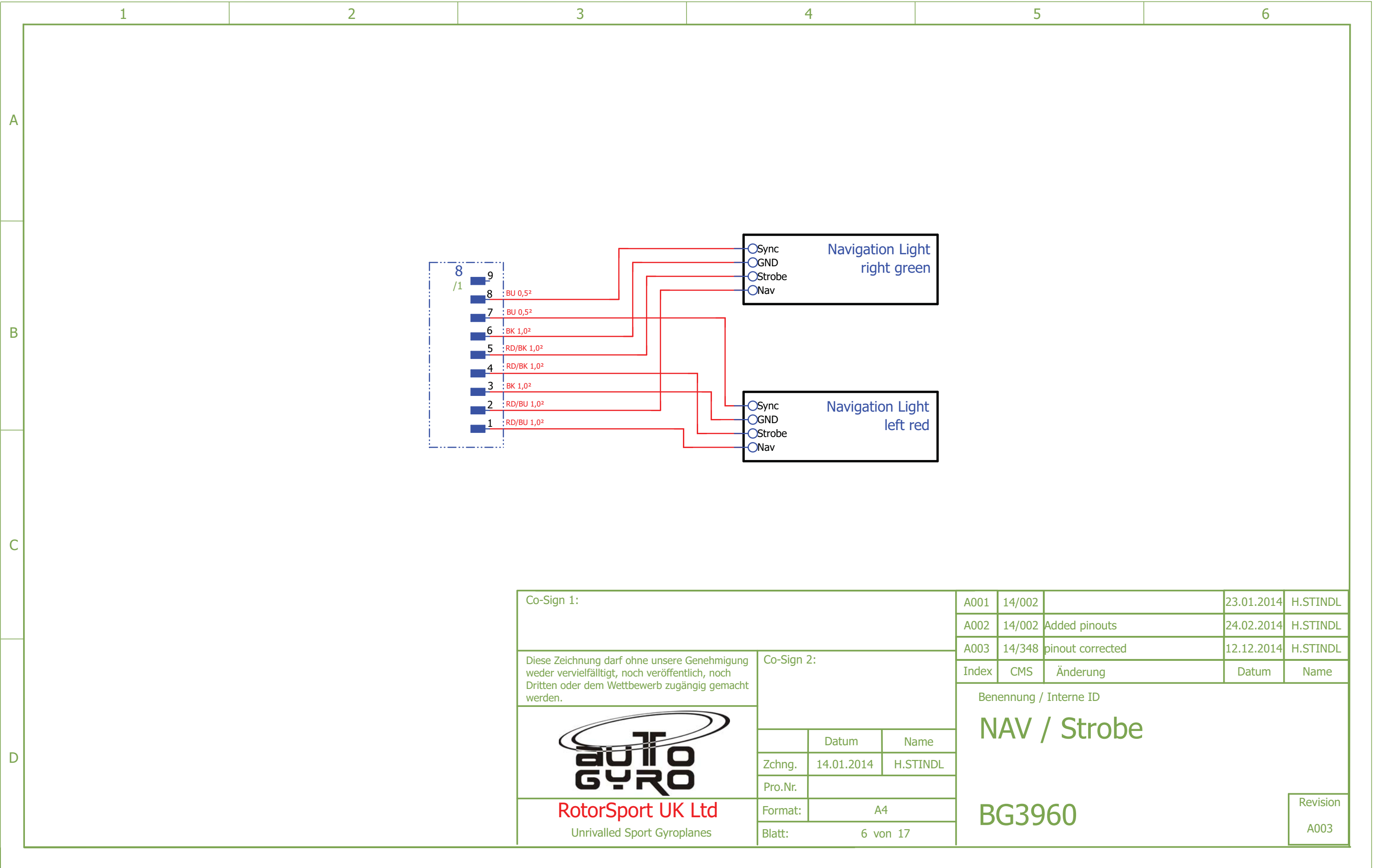

Co-Sign 1:		A001	14/002		23.01.2014	H.STINDL		
Diese Zeichnung darf ohne unsere Genehmigung weder vervielfältigt, noch veröffentlicht, noch Dritten oder dem Wettbewerb zugänglich gemacht werden.		Co-Sign 2:		A002	14/002	Added pinouts	24.02.2014	H.STINDL
		A003	14/348	pinout corrected	12.12.2014	H.STINDL		
		Index	CMS	Änderung	Datum	Name		
 RotorSport UK Ltd Unrivalled Sport Gyroplanes				Benennung / Interne ID				
				NAV / Strobe				
		Zchng.	14.01.2014	H.STINDL	BG3960			
		Pro.Nr.						
		Format:	A4		Revision A003			
		Blatt:	6 von 17					

Wiring Diagram – Cockpit LH (Standard)

1

2

3

4

5

6

A

B

C

D

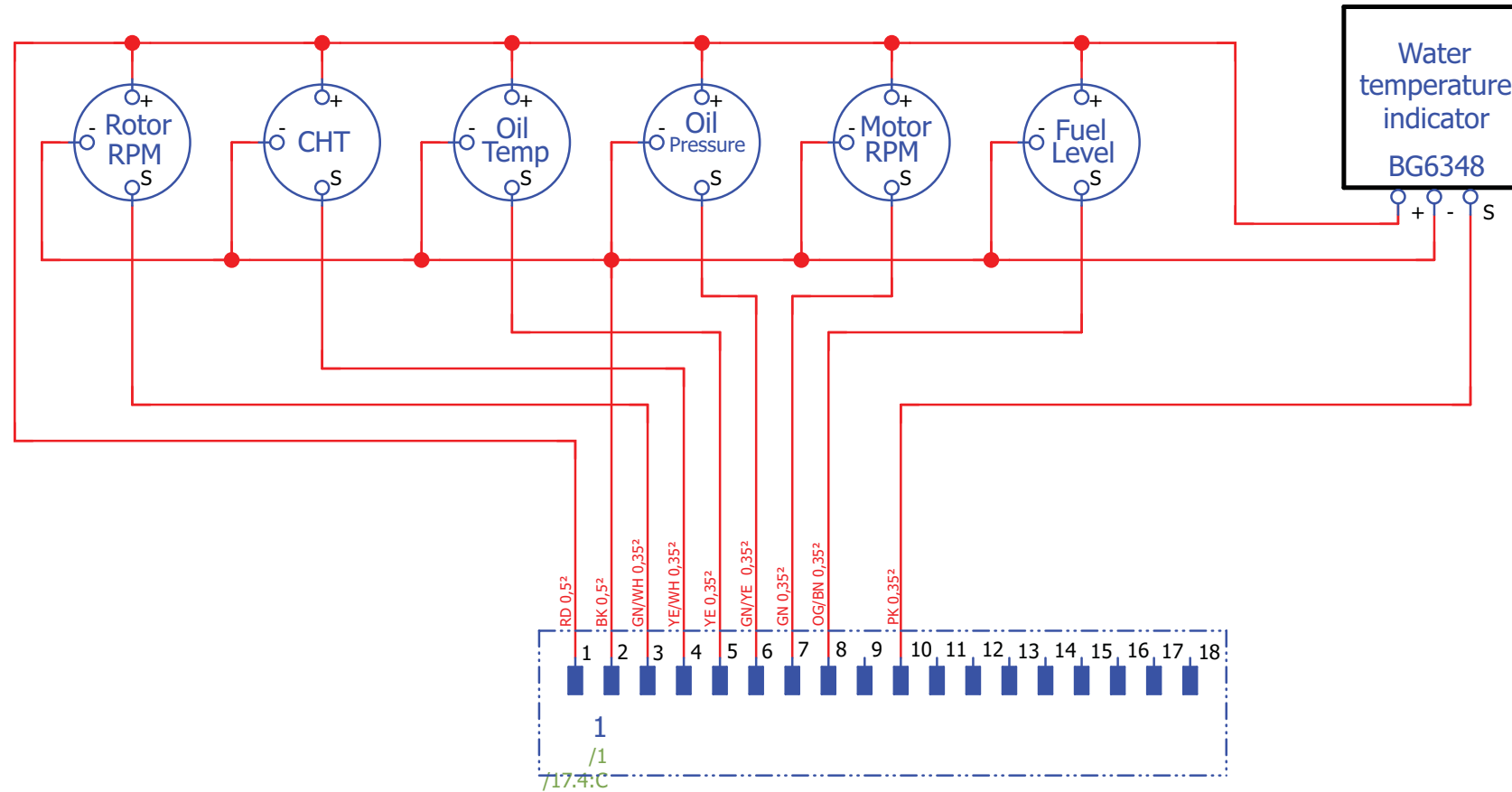

Co-Sign 1:

Diese Zeichnung darf ohne unsere Genehmigung weder vervielfältigt, noch veröffentlicht, noch Dritten oder dem Wettbewerb zugänglich gemacht werden.

RotorSport UK Ltd
Unrivalled Sport Gyroplanes

Co-Sign 2:

Zchnng.	Datum	Name
Pro.Nr.		
Format:	A4	
Blatt:	7 von 17	

A000			14.01.2014	H.STINDL
A001	14/002		23.01.2014	H.STINDL
Index	CMS	Änderung	Datum	Name
Benennung / Interne ID				
Cockpit links standard				
BG2108				
				Revision A001

Wiring Diagram – Main Fuse / Battery

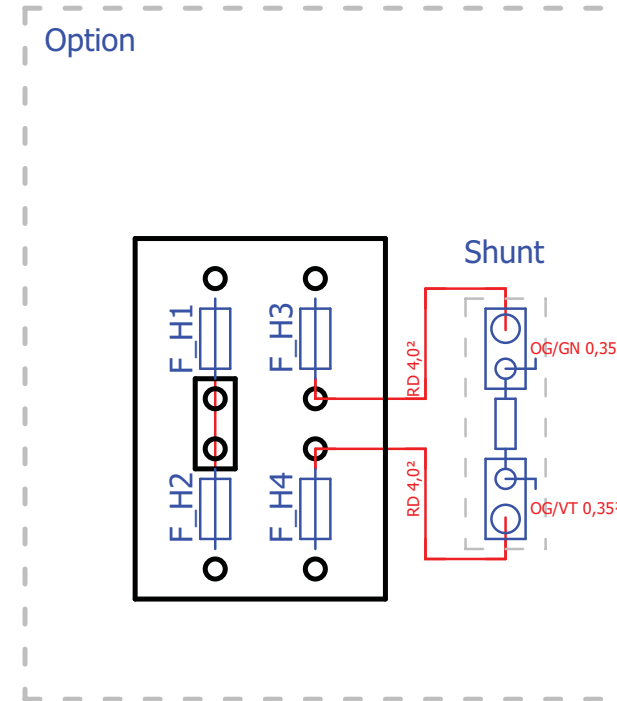
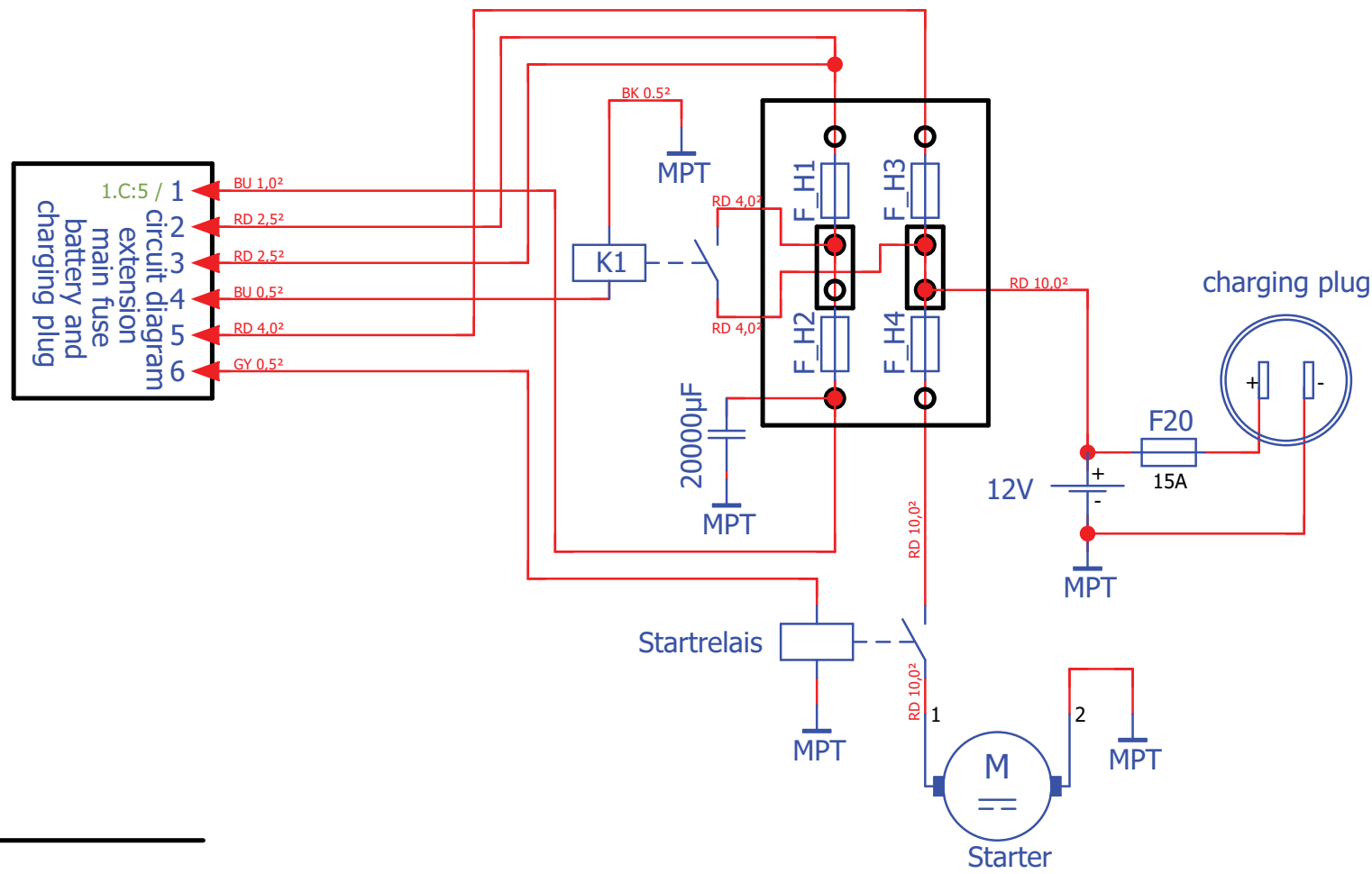

1	Pumpe 1
2	Laderegler B+
3	Laderegler R/C
4	Geschaltete Leitung
5	Schlüsselschalter Dauer +
6	Start (Anlasser)

F_H1	30A (UK 25A)
F_H2	10A
F_H3	40A
F_H4	125A (UK 100A)

Diese Zeichnung darf ohne unsere Genehmigung weder vervielfältigt, noch veröffentlicht, noch Dritten oder dem Wettbewerb zugänglich gemacht werden.



RotorSport UK Ltd
Univalled Sport Gyroplanes

co-sig 1:		co-sig 2:	
	Datum		Name
Zchng.	14.01.2014		H.STINDL
Gepr.			
Format:	A4		
Blatt:	8 von 16		

A004	14/002	update linkname	17.02.2014	H.STINDL
A005	14/002	added wire colors	21.02.2014	H.STINDL
A006	14/002	UK fuses	24.02.2014	H.STINDL
Index	CMS	Änderung	Datum	Name

Benennung / Interne ID

Hauptsicherung/Batterie

BG2148

Revision
A006

Wiring Diagram – Cockpit Centre

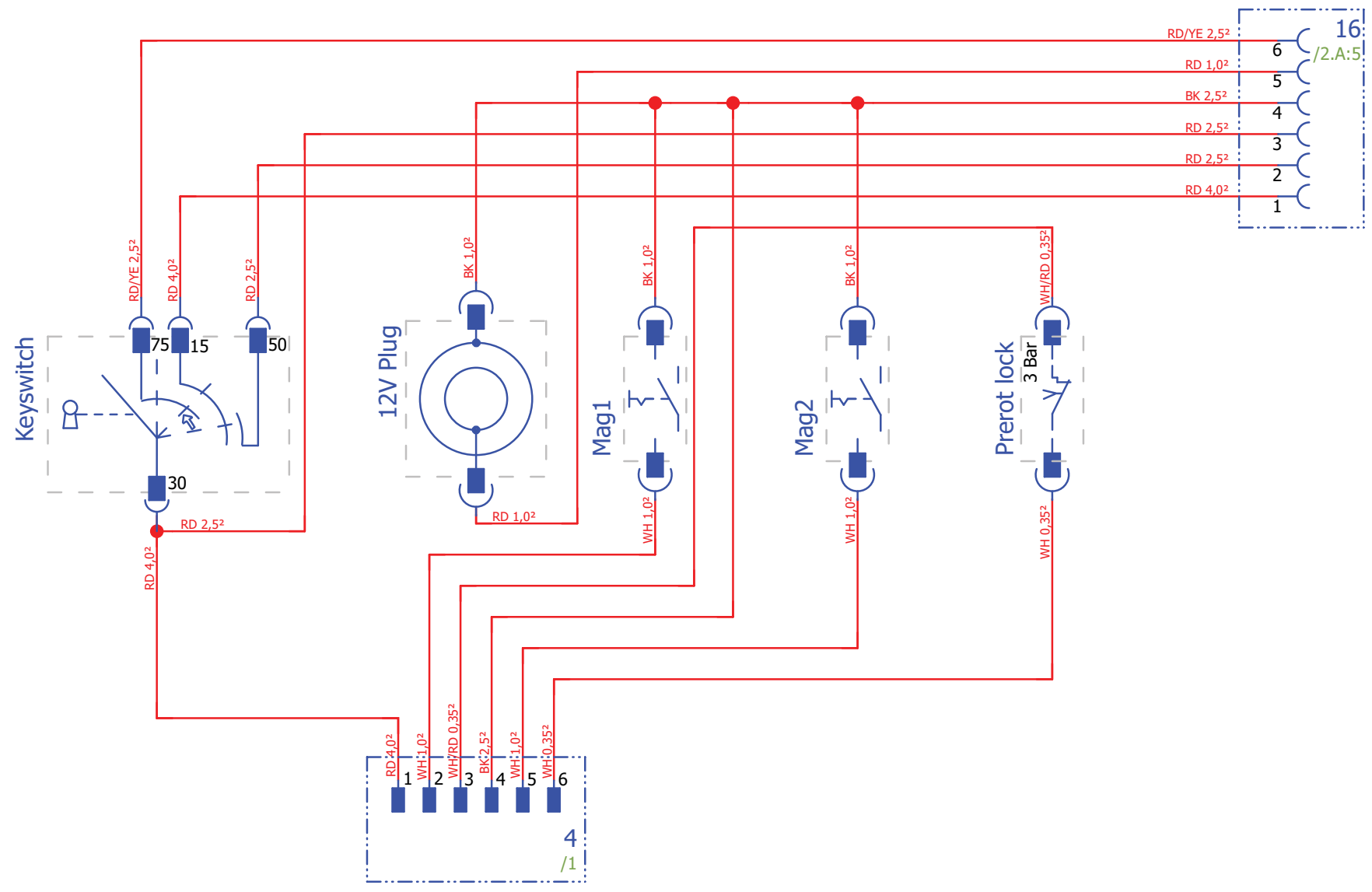

Co-Sign 1:

Diese Zeichnung darf ohne unsere Genehmigung weder vervielfältigt, noch veröffentlicht, noch Dritten oder dem Wettbewerb zugänglich gemacht werden.



RotorSport UK Ltd
Unrivalled Sport Gyroplanes

Co-Sign 2:

	Datum	Name
Zchnng.	15.01.2014	H.STINDL
Pro.Nr.		
Format:	A4	
Blatt:	9 von 17	

A001	14/002		23.01.2014	H.STINDL
A002	14/002	Added pinouts	24.02.2014	H.STINDL
A003		shifted drawing	08.08.2014	H.STINDL
Index	CMS	Änderung	Datum	Name

Benennung / Interne ID

Stromlaufplan Cockpit mitte

BG2107

Revision	A003
----------	------

Wiring Diagram – Cockpit (General)

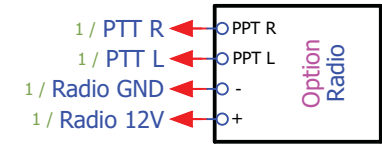
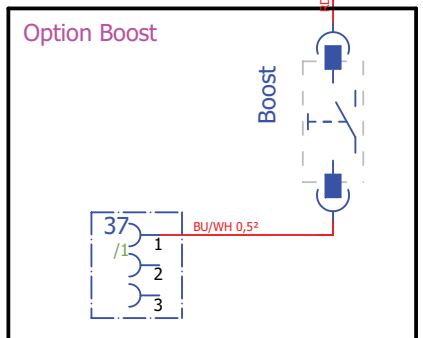
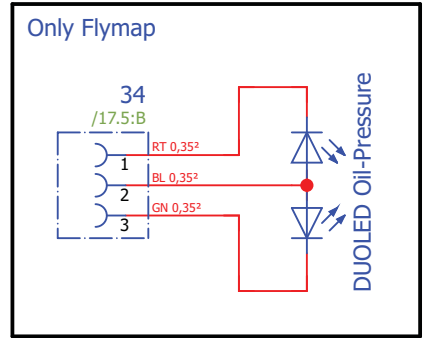
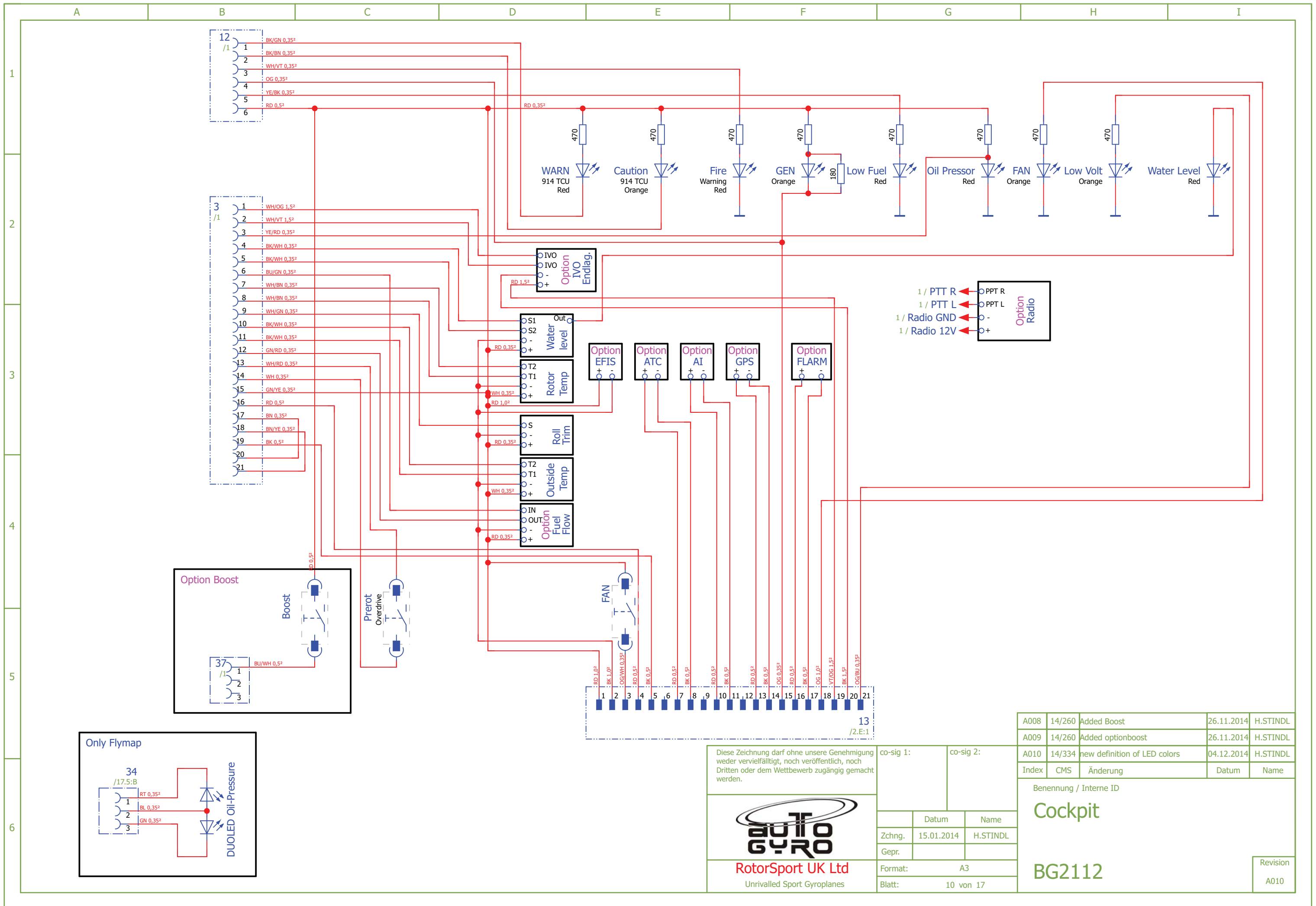

Diese Zeichnung darf ohne unsere Genehmigung weder vervielfältigt, noch veröffentlicht, noch Dritten oder dem Wettbewerb zugänglich gemacht werden.



RotorSport UK Ltd
Unrivalled Sport Gyroplanes

co-sig 1:	co-sig 2:	
Datum	Name	
Zchnng.	15.01.2014	H.STINDL
Gepr.		
Format:	A3	
Blatt:	10 von 17	

A008	14/260	Added Boost	26.11.2014	H.STINDL
A009	14/260	Added optionboost	26.11.2014	H.STINDL
A010	14/334	new definition of LED colors	04.12.2014	H.STINDL
Index	CMS	Änderung	Datum	Name

Benennung / Interne ID	
Cockpit	
BG2112	
Revision	A010

Wiring Diagram – Pneumatic System (Standard / Comfort)

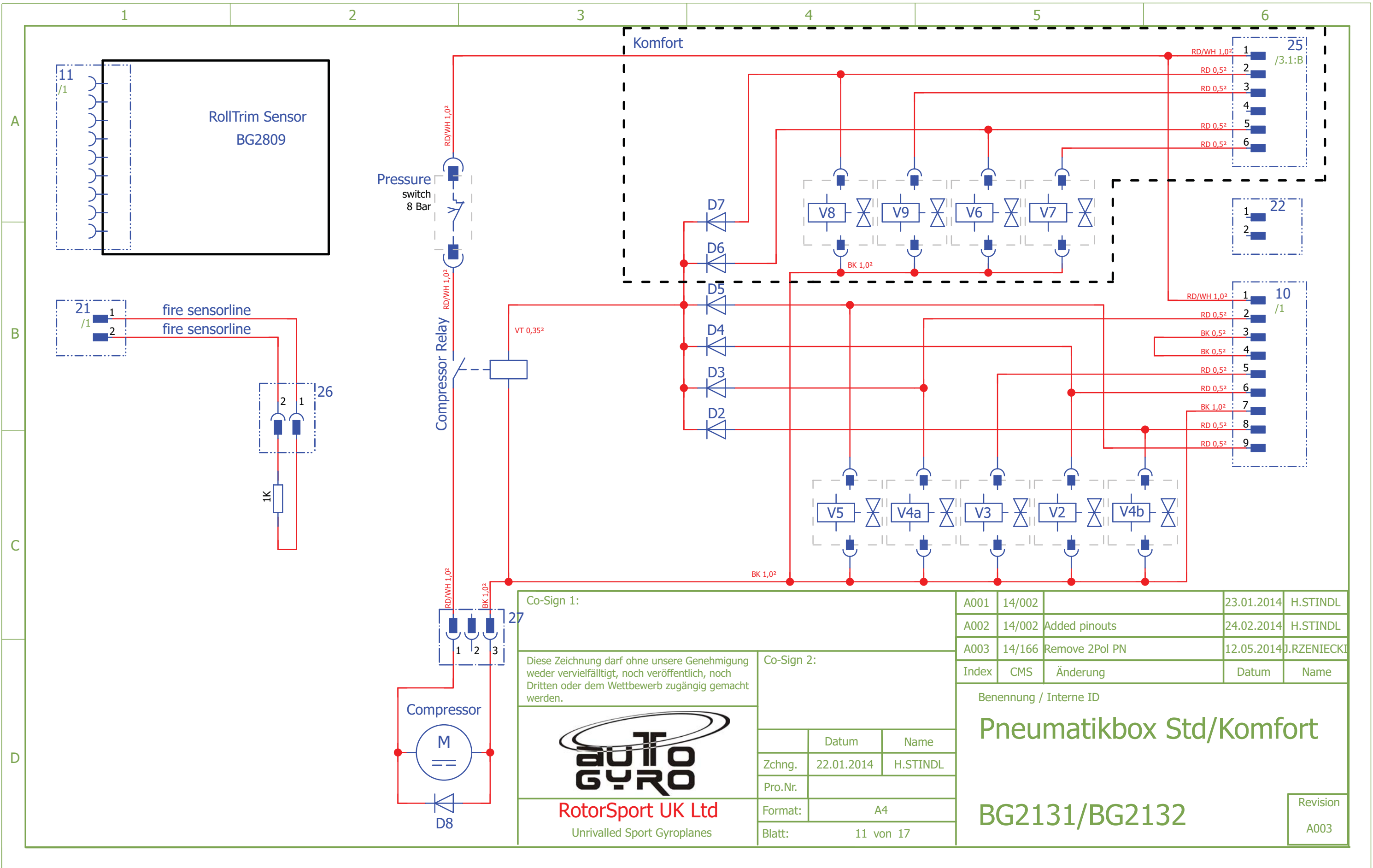

Co-Sign 1:

Diese Zeichnung darf ohne unsere Genehmigung weder vervielfältigt, noch veröffentlicht, noch Dritten oder dem Wettbewerb zugänglich gemacht werden.



RotorSport UK Ltd
Unrivalled Sport Gyroplanes

Co-Sign 2:

	Datum	Name
Zchnng.	22.01.2014	H.STINDL
Pro.Nr.		
Format:	A4	
Blatt:	11 von 17	

A001	14/002		23.01.2014	H.STINDL
A002	14/002	Added pinouts	24.02.2014	H.STINDL
A003	14/166	Remove 2Pol PN	12.05.2014	J.RZENIECKI
Index	CMS	Änderung	Datum	Name

Benennung / Interne ID

Pneumatikbox Std/Komfort

BG2131/BG2132

Revision
A003

Wiring Diagram – Fuel Pumps

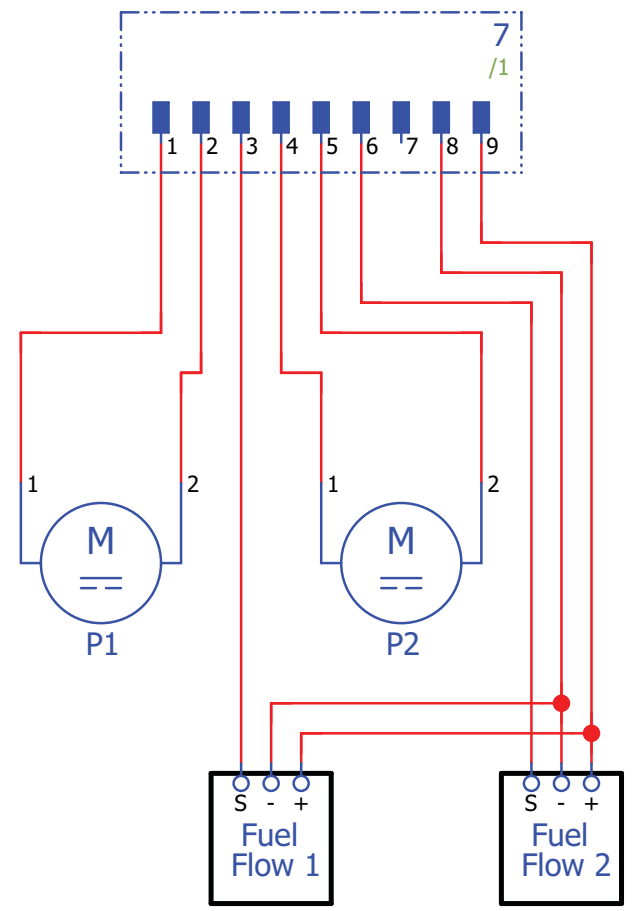

Co-Sign 1:

Diese Zeichnung darf ohne unsere Genehmigung weder vervielfältigt, noch veröffentlicht, noch Dritten oder dem Wettbewerb zugänglich gemacht werden.



RotorSport UK Ltd
Unrivalled Sport Gyroplanes

Co-Sign 2:

	Datum	Name
Zchnng.	22.01.2014	H.STINDL
Pro.Nr.		
Format:	A4	
Blatt:	12 von 17	

A000			22.01.2014	H.STINDL
A001	14/002		23.01.2014	H.STINDL
A002		shifted drawing	08.08.2014	H.STINDL
Index	CMS	Änderung	Datum	Name

Benennung / Interne ID

Benzinpumpen

BG2180

Revision
A002

Wiring Diagram – Fuel Level and Low Level Sensors

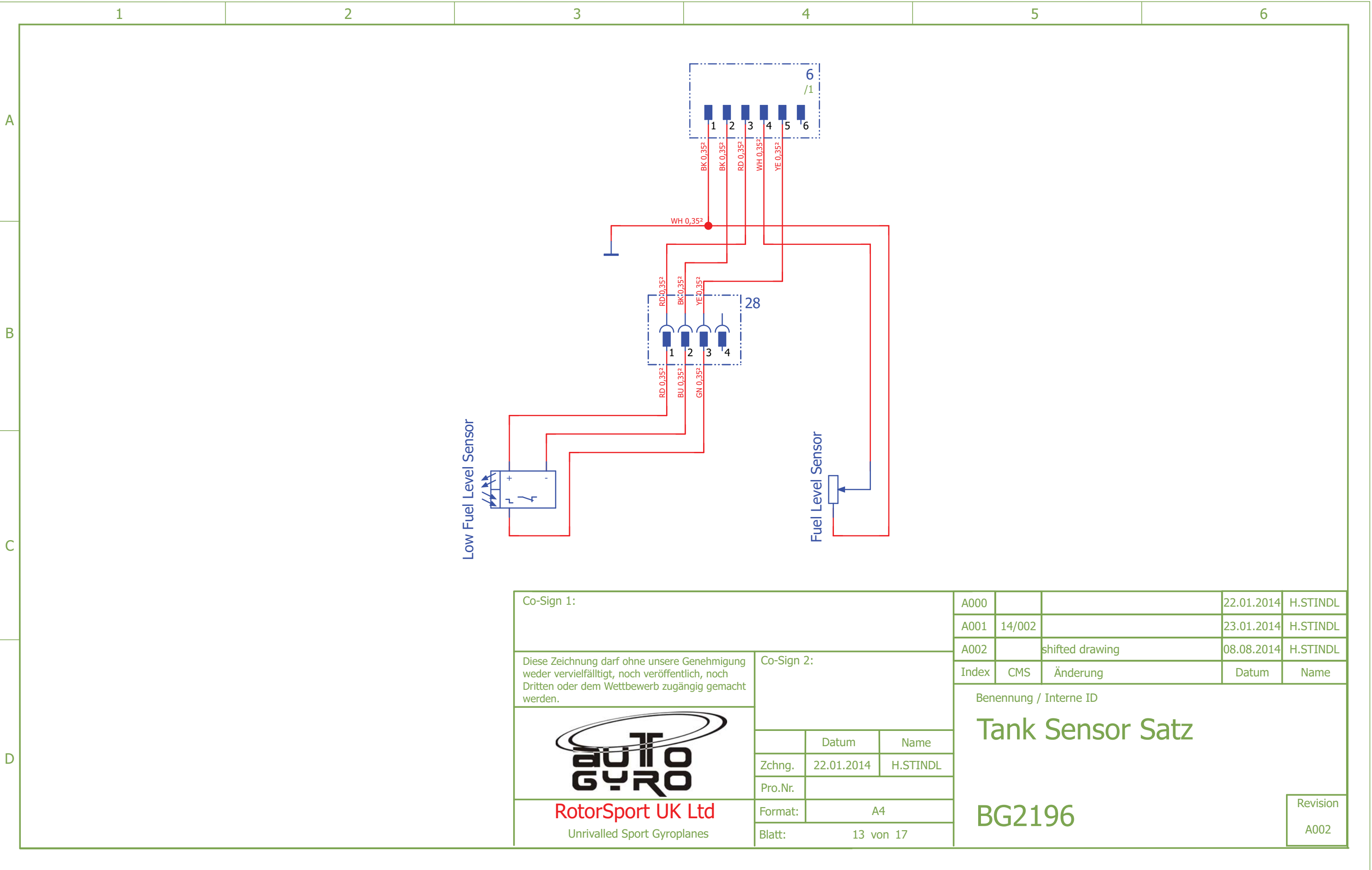

Co-Sign 1:		A000		22.01.2014	H.STINDL
		A001	14/002	23.01.2014	H.STINDL
		A002	shifted drawing	08.08.2014	H.STINDL
		Index	CMS	Änderung	Datum
		Benennung / Interne ID			
		Tank Sensor Satz			
		BG2196			
		Revision			
		A002			

Diese Zeichnung darf ohne unsere Genehmigung weder vervielfältigt, noch veröffentlicht, noch Dritten oder dem Wettbewerb zugänglich gemacht werden.		Co-Sign 2:	
 RotorSport UK Ltd Unrivalled Sport Gyroplanes		Datum	Name
		Zchnng.	22.01.2014 H.STINDL
		Pro.Nr.	
		Format:	A4
		Blatt:	13 von 17

Wiring Diagram – Engine Wiring Harness

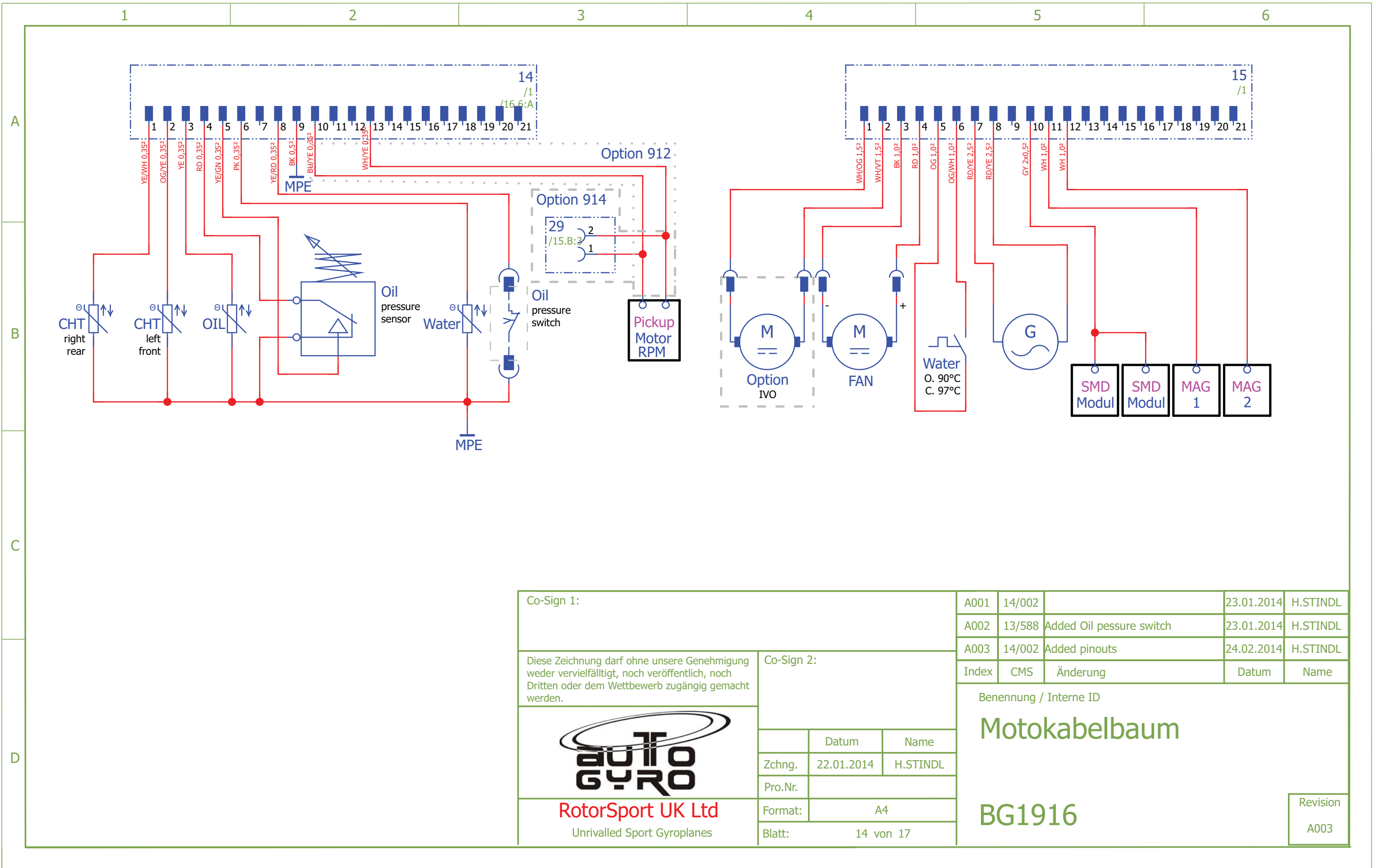

Co-Sign 1:		A001	14/002		23.01.2014	H.STINDL
		A002	13/588	Added Oil pessure switch	23.01.2014	H.STINDL
		A003	14/002	Added pinouts	24.02.2014	H.STINDL
		Index	CMS	Änderung	Datum	Name
Diese Zeichnung darf ohne unsere Genehmigung weder vervielfältigt, noch veröffentlicht, noch Dritten oder dem Wettbewerb zugänglich gemacht werden.		Co-Sign 2:				
 RotorSport UK Ltd Unrivalled Sport Gyroplanes			Datum	Name	Benennung / Interne ID Motokabelbaum BG1916	
		Zchnng.	22.01.2014	H.STINDL		
		Pro.Nr.				
		Format:	A4			
		Blatt:	14 von 17			
						Revision A003

Wiring Diagram – Engine Turbo Control Unit (TCU) Wiring Harness

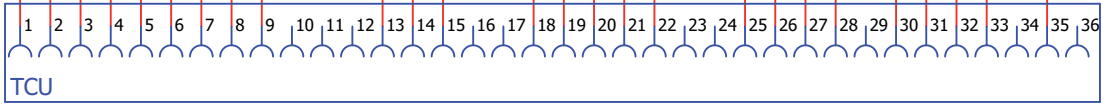
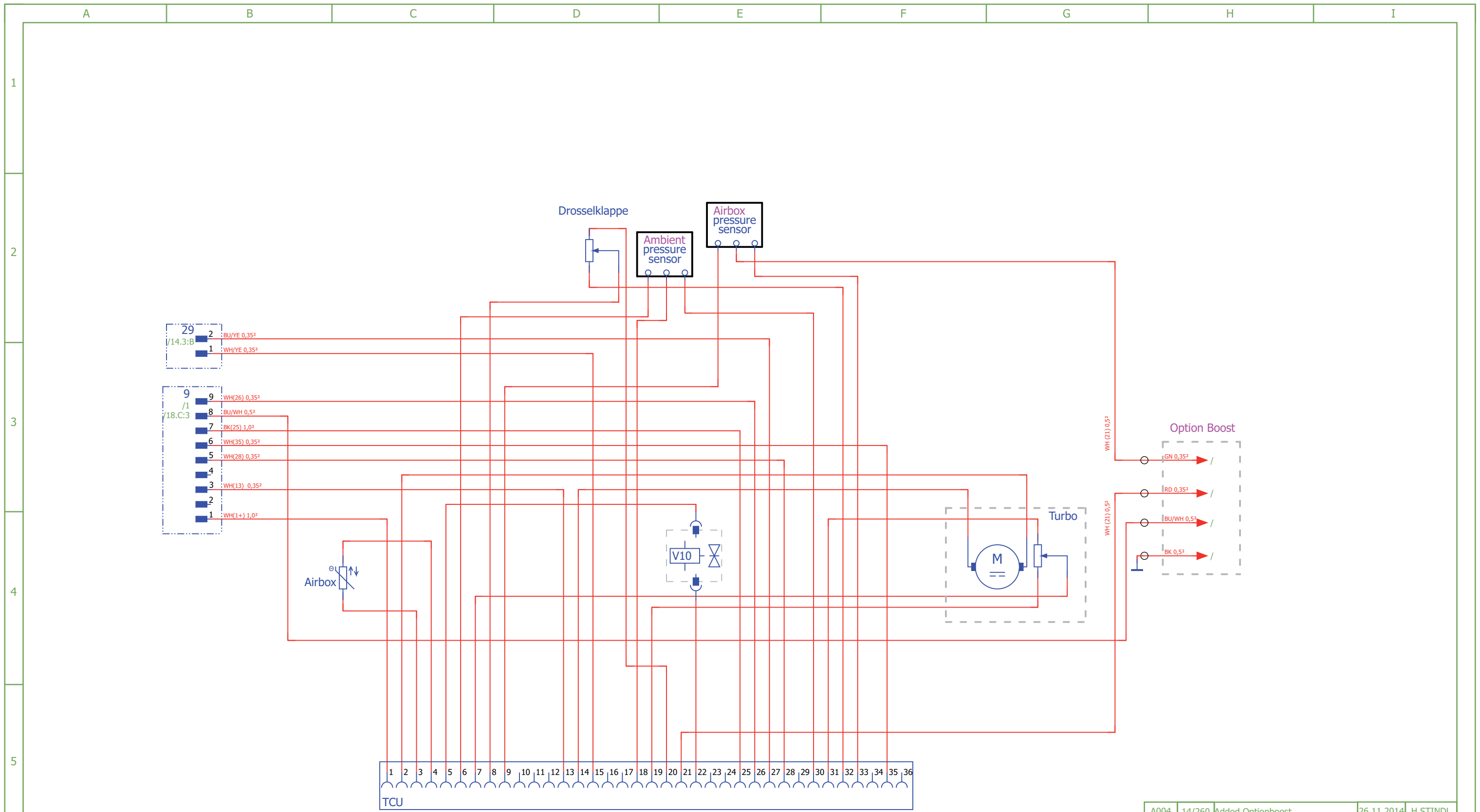

Diese Zeichnung darf ohne unsere Genehmigung weder vervielfältigt, noch veröffentlicht, noch Dritten oder dem Wettbewerb zugänglich gemacht werden.



RotorSport UK Ltd
Unrivalled Sport Gyroplanes

co-sig 1:		co-sig 2:	
	Datum	Name	
Zchnng.	22.01.2014	H.STINDL	
Gepr.			
Format:	A3		
Blatt:	15a von 18		

A004	14/260	Added Optionboost	26.11.2014	H.STINDL
A005	15/299	Corrected drawing	27.07.2015	H.STINDL
A006	15/299	cabl labeling changed	05.08.2015	H.STINDL
Index	CMS	Änderung	Datum	Name

Benennung / Interne ID	
TCU Kabelbaum	
BG3210	
Revision	A006

Pneumatic Scheme - Standard

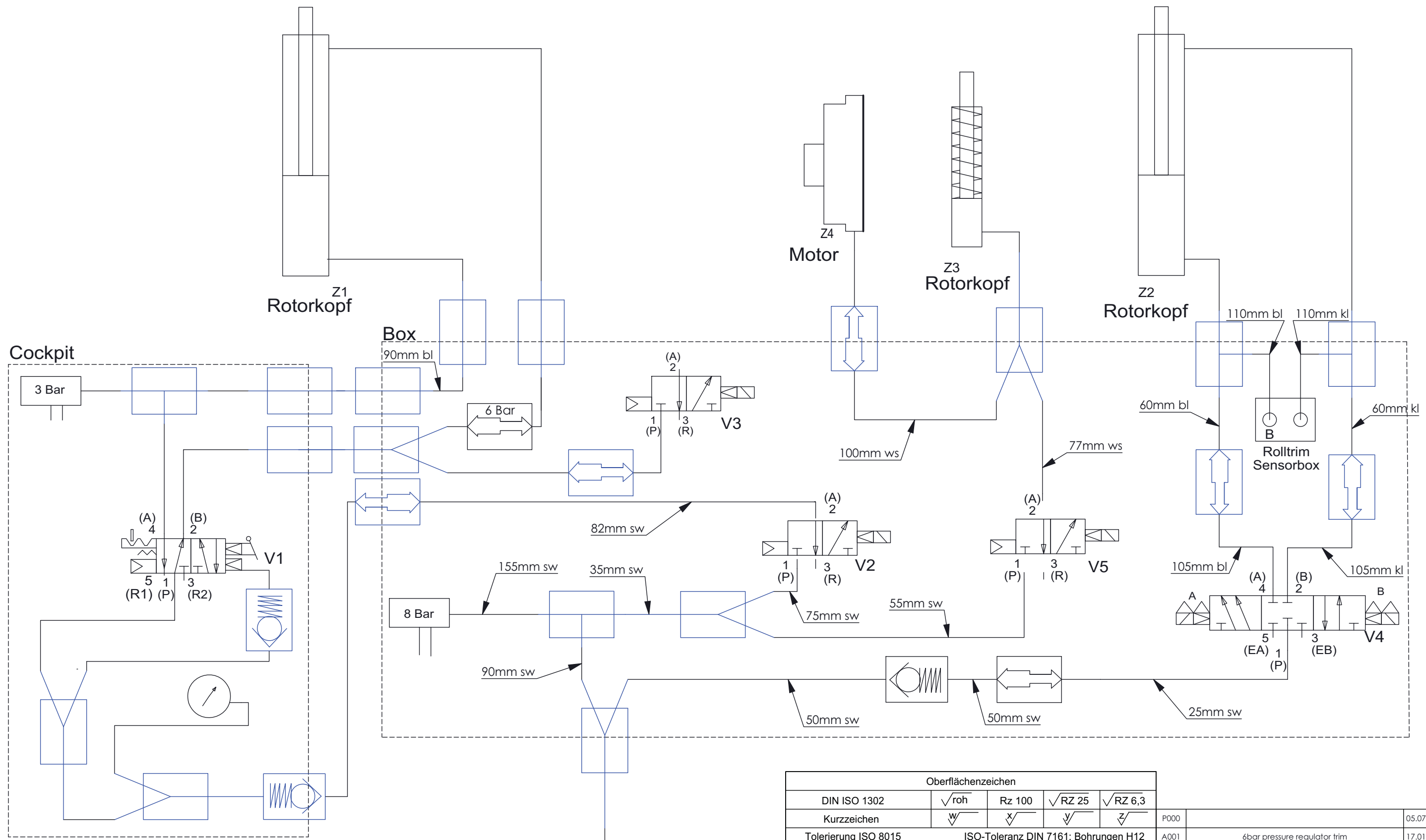

- V1 5/2 Wegeventil (Trimm/Break)
- V2 3/2 Wegeventil elektr. (Nick-Trim slow)
- V3 3/2 Wegeventil elektr. (Nick-Trim fast)
- V4 5/3 Wegeventil elektr. (Roll-Trim)
- A Trimm left
- B Trimm right
- V5 3/2 Wegeventil elektr. (Prerotator)
- P1 Pumpe
- A1 Druckgefäß/Filter (alle 100h zu wechseln)
- Z1 Trimmzylinder (Nick-Trim)
- Z2 Trimmzylinder (Roll-Trim)
- Z3 Prerotatorzylinder
- Z4 Pneumatik Kupplung

Oberflächenzeichen									
DIN ISO 1302	\sqrt{roh}	Rz 100	$\sqrt{RZ 25}$	$\sqrt{RZ 6,3}$					
Kurzzeichen	\sqrt{w}	\sqrt{v}	\sqrt{z}	\sqrt{z}					
Tolerierung ISO 8015	ISO-Toleranz DIN 7161: Bohrungen H12								
Freimaß-, Form- und Lagetoleranzen nach ISO 2768-mH									
Nennmaß	6	30	120	315	1000	2000	+2000		
Abmaß	±0,1	±0,2	±0,3	±0,5	±0,8	±1,2	±2		
Diese Zeichnung darf ohne unsere Genehmigung weder vervielfältigt, noch veröffentlicht, noch Dritten oder dem Wettbewerb zugänglich gemacht werden.					Datum	Name			
					Modell				
					Zchnng.	17.01.2013	j.rzeniecki		
					Gepr.				
					Format:	A3	Maßstab		
					Blatt:	1 von 1	1:1 (1:5)		
SolidWorks 2010					Benennung / Interne ID				
					Pneumatikbox Standard Pneumatikplan				
					BG2131				
					Revision				
					A001				

Pneumatikbox Standard
Pneumatikplan
BG2131

Revision
A001

Pneumatic Scheme - Comfort

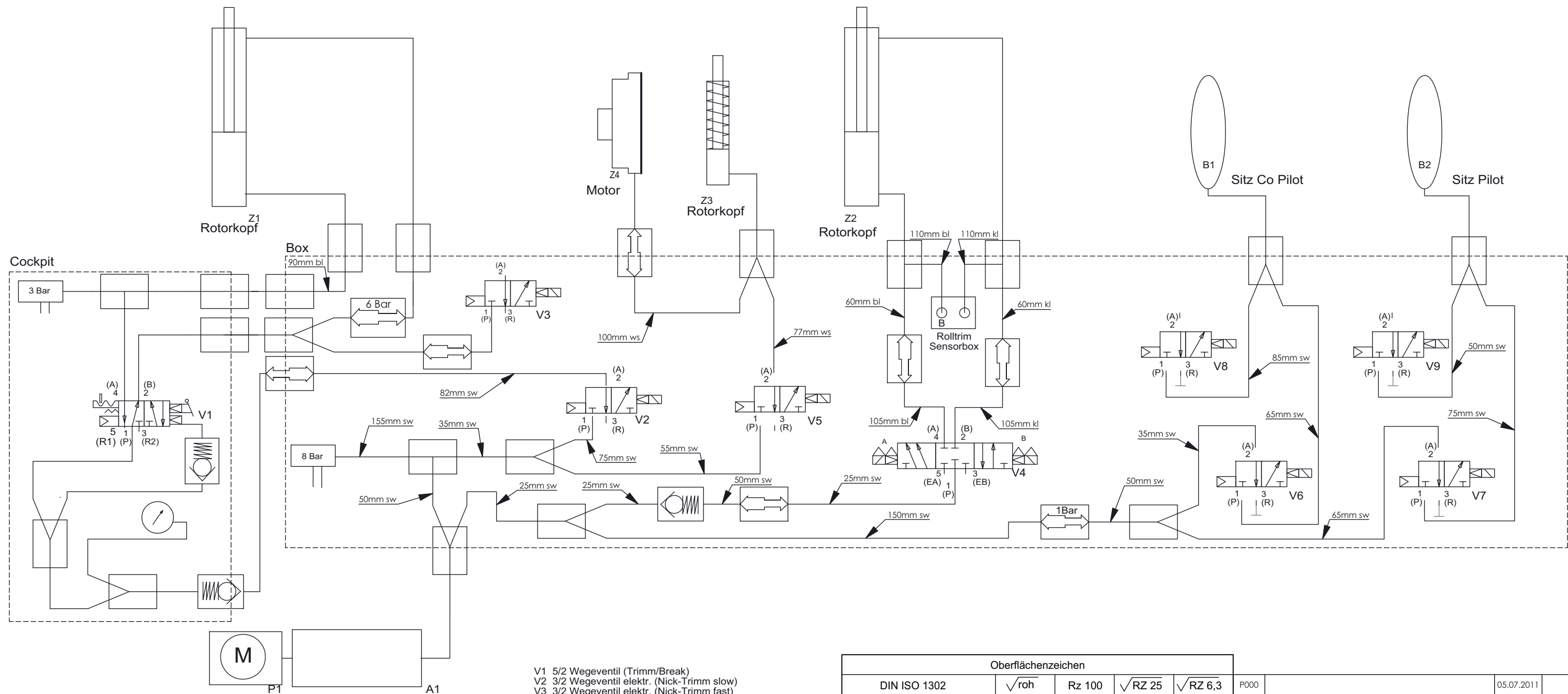

- V1 5/2 Wegeventil (Trim/Break)
- V2 3/2 Wegeventil elektr. (Nick-Trim slow)
- V3 3/2 Wegeventil elektr. (Nick-Trim fast)
- V4 5/3 Wegeventil elektr. (Roll-Trim)
- A Trimm left
- B Trimm right
- V5 3/2 Wegeventil elektr. (Prerotator)
- V6 3/2 Wegeventil elektr. "R" geschlossen (Aufblasen)
- V7 3/2 Wegeventil elektr. "R" geschlossen (Ablassen)
- V8 3/2 Wegeventil elektr. "R" geschlossen (Aufblasen)
- V9 3/2 Wegeventil elektr. "R" geschlossen (Ablassen)
- P1 Pumpe
- A1 Druckgefäß/Filter (alle 100h zu wechseln)
- Z1 Trimmzylinder (Nick-Trim)
- Z2 Trimmzylinder (Roll-Trim)
- Z3 Prerotatorzylinder
- Z4 Pneumatik Kupplung
- B1 Luftkissen
- B2 Luftkissen

Oberflächenzeichen							
DIN ISO 1302	\sqrt{roh}	Rz 100	$\sqrt{RZ 25}$	$\sqrt{RZ 6,3}$	P000		05.07.2011
Kurzzeichen	\sqrt{w}	\sqrt{x}	\sqrt{y}	\sqrt{z}	P001		19.07.2011
Tolerierung ISO 8015	ISO-Toleranz DIN 7161: Bohrungen H12				A001	6bar pressure regulator trim	17.01.2013
Freimaß-, Form- und Lagetoleranzen nach ISO 2768-mH							
Nennmaß	6	30	120	315	1000	2000	+2000
Abmaß	±0,1	±0,2	±0,3	±0,5	±0,8	±1,2	±2
Diese Zeichnung darf ohne unsere Genehmigung weder vervielfältigt, noch veröffentlicht, noch Dritten oder dem Wettbewerb zugänglich gemacht werden.							
Datum		Name					
Modell							
Zchnng.		17.01.2013		j.rzeniecki			
Gepr.							
Format: A3		Blatt: 1 von 1		Maßstab: 1:1 (1:5)			
SolidWorks 2010							
Material / Legierung. :							
Oberfläche..... :							
Gewicht [g]..... : (berechnet)							
Abmessung..... :							
Benennung / Interne ID							
Pneumatikbox Komfort							
Pneumatikplan							
BG2132							
Revision							
A001							

Retrofit: End Position Detection IVO Propeller

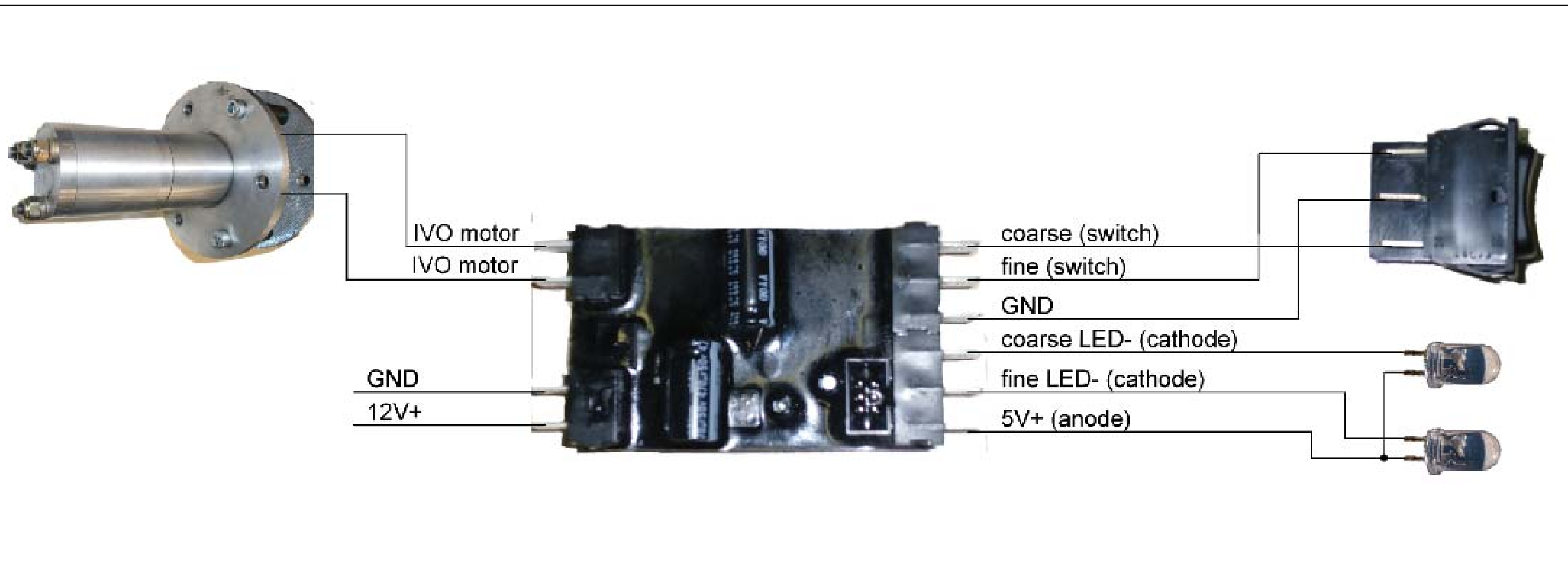

Oberflächenzeichen							
DIN ISO 1302	$\sqrt{\text{roh}}$	Rz 100	$\sqrt{\text{RZ 25}}$	$\sqrt{\text{RZ 6,3}}$			
Kurzzeichen	$\sqrt{\text{w}}$	$\sqrt{\text{x}}$	$\sqrt{\text{y}}$	$\sqrt{\text{z}}$			
Tolerierung ISO 8015		ISO-Toleranz DIN 7161: Bohrungen H12					
Freimaß-, Form- und Lagetoleranzen nach ISO 2768-mH							
Nennmaß	6	30	120	315	1000	2000	+2000
Abmaß	±0,1	±0,2	±0,3	±0,5	±0,8	±1,2	±2
Diese Zeichnung darf ohne unsere Genehmigung weder vervielfältigt, noch veröffentlicht, noch Dritten oder dem Wettbewerb zugänglich gemacht werden.				Datum		Name	
				Modell			
				Zchnng.	17.04.2013	h.stindl	
				Gepr.			
						Maßstab	
				Format: A3		1:1 (1:5)	
				Blatt: 1 von 1			
				SolidWorks 2010			

A000	\$PRPS HEET:{ CMS}		17.04.2013	h.stindl
Index	CMS	Änderung	Datum	Name
Material / Legierung. :				
Oberfläche..... :				
Gewicht [g]..... : (berechnet)				
Abmessung..... :				
Benennung / Interne ID				
IVO-Steuerungsplatine - Schematische Darstellung				
BG4652				Revision
				A000

Contents

07-00-00 2-1	LIFTING OF THE GYROPLANE
07-00-00 2-2	JACKING OF THE GYROPLANE
07-00-00 2-3	SHORING OF THE GYROPLANE
08-20-00 2-1	LEVELING OF THE GYROPLANE
24-30-00 4-1	REMOVAL-INSTALLATION: BATTERY
24-30-00 8-1	MODIFICATION: ELECTRICAL POWER SUPPLY TO THE FUEL PUMP I VIA RECTIFIER-REGULATOR (ROTAX 914)
25-60-00 0-1	DESCRIPTION: EMERGENCY LOCATOR TRANSMITTER (ELT)
26-00-00 0-1	DESCRIPTION: FIRE INDICATING SYSTEM
27-10-00 5-1	CHECK-ADJUSTMENT: ROLL CONTROL TRAVEL LIMITATION
27-20-00 5-1	CHECK-ADJUSTMENT: RUDDER CONTROL ANGLES
28-20-00 6-1	INSPECTION: FUEL FILTER
28-20-00 8-1	REPLACEMENT: FUEL FILTER
28-20-00 8-2	REPLACEMENT: ELECTRICAL FUEL PUMPS
32-10-00 8-1	REPLACEMENT: MAIN GEAR SUSPENSION BOW ATTACHMENT BOLTS
32-20-00 8-1	REPLACEMENT: NOSE GEAR RUBBER DAMPER
32-40-00 4-1	REMOVAL-INSTALLATION: WHEELS
32-40-00 8-1	REPLACEMENT: BRAKE LOCKING MECHANISM (see 76-10-00 8-1)
32-40-00 8-2	REPLACEMENT: MAIN WHEEL BRAKE PADS
32-40-00 8-3	REPLACEMENT: WHEEL BEARING
34-10-00 5-1	TEST: PITOT STATIC SYSTEM INTEGRITY
34-10-00 7-1	CLEANING: PITOT STATIC SYSTEM
36-21-00 8-1	REPLACEMENT: FILTER/DRYER
52-00-00 4-1	REMOVAL-INSTALLATION: COWLINGS
52-40-00 0-1	DESCRIPTION: SERVICE COVERS IN COCKPIT SHELL
55-00-00 8-1	REPLACEMENT: KEEL TUBE PROTECTION PAD
56-00-00 8-1	REPAIR: CRACKS IN ACRYLIC GLASS
61-10-00 4-1	REMOVAL-INSTALLATION: PROPELLER - HTC
61-10-00 4-2	DISASSEMBLY-ASSEMBLY: PROPELLER - HTC
61-10-00 5-1	ADJUSTMENT: PROPELLER PITCH - HTC
61-10-00 8-2	RETROFIT: END POSITION DETECTION IVO PROPELLER
61-20-00 1-1	TROUBLE-SHOOTING: IVO-VARIABLE PITCH PROPELLER
62-11-00 4-1	REMOVAL: ROTOR - TEETERING PARTS
62-11-00 4-2	DISASSEMBLY: ROTOR - TEETERING PARTS
62-11-00 4-3	ASSEMBLY: ROTOR - TEETERING PARTS
62-11-00 4-4	INSTALLATION: ROTOR - TEETERING PARTS
62-11-00 5-1	CHECK-ADJUSTMENT: ROTOR SYSTEM ALIGNMENT
62-11-00 6-1	INSPECTION: ROTOR - TEETERING PARTS
62-11-00 6-2	INSPECTION: ROTOR BLADES
62-11-00 6-3	INSPECTION: ROTOR HUB BOLTS
62-11-00 8-1	REPLACEMENT: TEETER BUSHINGS
62-20-00 8-1	REPLACEMENT: DRIVE GEAR
62-31-00 5-1	CHECK-ADJUSTMENT: ROTOR HEAD MAIN BOLT AXIS
62-31-00 6-1	INSPECTION: ROTOR HEAD BRIDGE, BEARING AND TEETER TOWER

62-32-00 5-1	CHECK-ADJUSTMENT: ROTOR CONTROL FRICTION
62-32-00 6-1	INSPECTION: ROTOR GIMBAL HEAD
62-51-00 4-1	REMOVAL-INSTALLATION: TOP MAST
62-51-00 6-1	INSPECTION: MAST MOUNTING BUSHINGS
62-51-00 8-1	REPLACEMENT: MAST MOUNTING BUSHINGS
63-11-10 4-1	REMOVAL-INSTALLATION: PRE-ROTATOR CLUTCH
63-11-10 5-1	CHECK-ADJUSTMENT: PRE_ROTATOR CLUTCH
63-11-10 6-1	INSPECTION: PRE-ROTATOR CLUTCH
63-11-10 8-1	REPLACEMENT: PRE-ROTATOR CLUTCH LINING
63-11-10 8-2	REPLACEMENT: PRE-ROTATOR CLUTCH DOG GEAR
63-11-30 6-1	INSPECTION: PRE-ROTATOR UPPER ENGAGEMENT
63-11-30 8-1	REPLACEMENT: PRE-ROTATOR UPPER BEARINGS
63-11-30 8-2	REPAIR: PRE-ROTATOR UPPER ENGAGEMENT
63-51-00 8-1	REPLACEMENT: ROTOR BRAKE PAD
67-00-00 5-1	CHECK-ADJUSTMENT: ROTOR CONTROL ANGLES (see 62-32-00 6-1)
67-00-00 6-1	INSPECTION: FLIGHT CONTROL PUSH-PULL CABLES
67-00-00 8-1	RETROFIT: PPC CLAMPS
67-05-00 8-1	REPLACEMENT: PITCH TRIM/BRAKE PNEUMATIC SEAL
67-10-00 4-1	REMOVAL-INSTALLATION: CENTRE CONSOLE
71-20-00 6-1	INSPECTION: CLEARANCE ENGINE INSTALLATION (R914)
71-30-00 4-1	REMOVAL-INSTALLATION: FIRE WALL
75-00-00 4-1	REMOVAL-INSTALLATION:RADIATOR
75-00-00 8-2	MODIFICATION: RECONFIGURE FAN REVERSE
78-20-00 8-1	REPLACEMENT: WOOL OF MUFFLER TUBE

07-00-00 2-1 LIFTING OF THE GYROPLANE

LNE

GENERAL, REFERENCES AND REQUIREMENTS

Task may only be performed by an organization or individual trained and entitled to carry out 'Line Maintenance'!

Secure gyroplane against unauthorized or unintended operation!

Rotor system must be removed, see [62-11-00 4-1](#)

SPECIAL TOOLS AND CONSUMABLE MATERIALS

None

PRECAUTIONS AND SAFETY MEASURES

WARNING: Object is heavy! Inadequate handling could cause injury. Use proper lifting techniques or assistance!

WARNING: When working with cranes or other lifting equipment the general safety regulations have to be respected at all times!

CAUTION: Never attempt to lift gyroplane with rotor system attached!

PROCEDURES

- 1 Re-install teeter bolt, hand-tighten castellated nut and secure castellated nut adequately.
- 2 Loop a lifting belt around the teeter bolt and carefully lift the gyroplane.

CAUTION: Do not use a chain or any lifting gear that could damage the surface of the teeter bolt

ILLUSTRATIONS



Lifting belt looped around teeter bolt

07-00-00 2-2 JACKING OF THE GYROPLANE

LNE

GENERAL, REFERENCES AND REQUIREMENTS

Task may only be performed by an organization or individual trained and entitled to carry out 'Line Maintenance'!

Secure gyroplane against unauthorized or unintended operation!

Gyroplane must be placed on level ground and restrained (blocks, chocks)

SPECIAL TOOLS AND CONSUMABLE MATERIALS

None

PRECAUTIONS AND SAFETY MEASURES

PROCEDURES

Unload nose gear

- 1 In order to unload the nose gear lift at the jacking point at the fuselage belly right behind nose wheel, using a soft non-slip lining.

Unload main gear

- 2 In order to unload one of the main wheels carefully lift at the main gear suspension spar. Use a soft non-slip lining and chose lifting point close to the centre, but on the side of the affected wheel.
- 3 Continue to jack slowly and let the gyroplane rest stable on nose wheel, one main wheel and jack. Weights may be used on the opposite side of the suspension spar.

NOTE: Sand bags or load may be used to add additional weight on the desired side.

- 4 Secure gyroplane adequately before commencing work and do not leave unattended in jacked position.

07-00-00 2-3 SHORING OF THE GYROPLANE

OPR

GENERAL, REFERENCES AND REQUIREMENTS

Basic operational task, which can be performed by a licensed pilot or instructed personnell!

Rotor system must be removed, see [62-11-00 4-1](#)

SPECIAL TOOLS AND CONSUMABLE MATERIALS

None

PRECAUTIONS AND SAFETY MEASURES

CAUTION: Never use tie-down equipment or lashing straps in a way that would exert unsupported stress or high momentum on the structure of the gyroplane!

CAUTION: The suspension bow is not designed to take up high longitudinal forces!

PROCEDURES

Shoring, road transport or container transport

WARNING: The rotor system must be removed, disassembled and carefully packed for road transport.

CAUTION: When wrapping the gyroplane make sure that foil or stretch does not cover the painted surface directly. Put a soft layer in between for damage protection and let plastic components breathe. Do not expose wrapped gyroplane or parts to sun radiation or heat in order to avoid paint damage.

- 1 Restrain main wheels (blocks/chocks). For container transport replace main wheels with wooden blocks to provide safe stand.
- 2 Put a wooden block below the lowest point of the keel tube and lash keel tube against wooden block. The block should be dimensioned so that the main wheels (if installed) are half way unloaded.
- 3 Lash-down both main wheels through the lashing lugs (use rims/axles alternatively) and/or the mast tie-down kit (option).
- 4 Lash-down nose wheel through its axle.
- 5 For container transport or shipping, use the mast tie-down kit (option) and consider folding the mast.

PARTS LIST

Fig.	Pos.	Description	PC PIT	Remark
		shipping attachment mast	85-00-00-V-33480	

ILLUSTRATIONS

YES

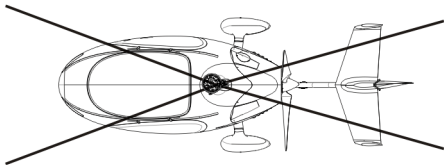
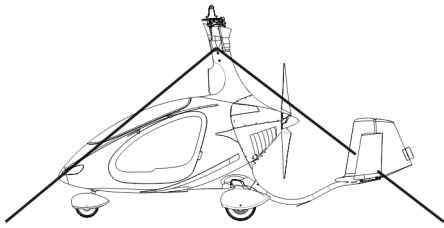

Lash-down mast top (kit available)

NO!

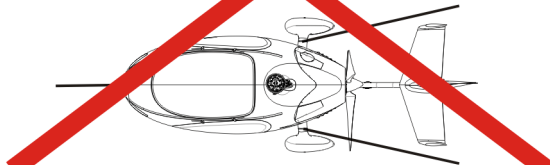
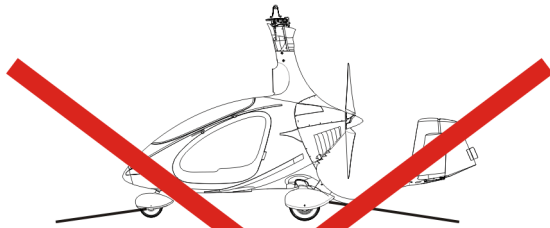

Never strap/tighten suspension bow in any longitudinal direction!

Fig. 1 - Lash-down methods of gyroplane

08-20-00 2-1 LEVELING OF THE GYROPLANE

LNE

GENERAL, REFERENCES AND REQUIREMENTS

Task may only be performed by an organization or individual trained and entitled to carry out 'Line Maintenance'!

Secure gyroplane against unauthorized or unintended operation!

Gyroplane must be placed on level ground and restrained (blocks, chocks)

SPECIAL TOOLS AND CONSUMABLE MATERIALS

None

PRECAUTIONS AND SAFETY MEASURES

PROCEDURES

Measurement of Stabilizer Alignment

- 1 Measure distance from the edge of the stabilizer fin to the door handle recess (see Fig. 1). Note values for RH and LH side.
- 2 RH dimension must be equal or less LH dimension. If in doubt contact AutoGyro customer support.

ILLUSTRATIONS



Fig. 1 - Measurement of Stabilizer Alignment (RH side shown)

24-30-00 4-1 REMOVAL-INSTALLATION: BATTERY

LNE

GENERAL, REFERENCES AND REQUIREMENTS

Task may only be performed by an organization or individual trained and entitled to carry out 'Line Maintenance'!

Secure gyroplane against unauthorized or unintended operation!

Engine cowlings must be removed, see [52-00-00 4-1](#)

Fire wall must be removed, see [71-30-00 4-1](#)

SPECIAL TOOLS AND CONSUMABLE MATERIALS

LR **IMPORTANT NOTE:** Procedure involves parts with limited reusability. Check parts list below before starting job!

PRECAUTIONS AND SAFETY MEASURES

WARNING: Electrical shorting of the battery will produce high current with the risk of personal injury and damage to equipment!

PROCEDURES

Removal

WARNING: Be careful to avoid electrical short cuts at all means.

- 1 Remove ground (L-) connection at the frame and isolate metallic cable shoe.
- 2 Remove hot (L+) cable at the battery.
- 3 Untighten battery retainer and remove battery.

Installation

- 4 Install battery in reverse order (work steps 3 to 1).

ILLUSTRATIONS

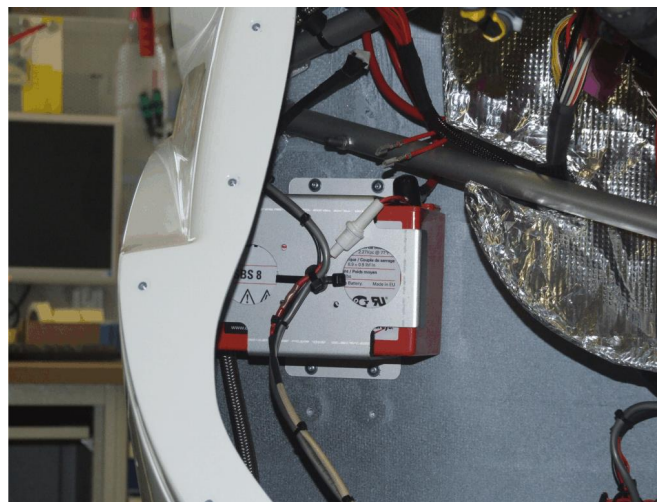

Fig. 1 - Installation Position Battery

24-30-00 8-1 MODIFICATION: ELECTRICAL POWER SUPPLY TO THE FUEL PUMP I VIA RECTIFIER-REGULATOR (ROTAX 914)

HVY

GENERAL, REFERENCES AND REQUIREMENTS

Task may only be performed by an organization trained and entitled to carry out 'Heavy Maintenance'!

Secure gyroplane against unauthorized or unintended operation!

Self-locking nuts and split pins must only be used once and discarded! Check availability of new hardware before commencing work!

Engine cowlings must be removed, see [52-00-00 4-1](#)

Battery must be disconnected, see [24-30-00 4-1, steps 1-2](#)

Fire wall must be removed, see [71-30-00 4-1](#)

SPECIAL TOOLS AND CONSUMABLE MATERIALS

PRECAUTIONS AND SAFETY MEASURES

WARNING: Electrical shorting of the battery will produce high current with the risk of personal injury and damage to equipment!

CAUTION: Failure to comply with this instruction will cause the loss of warranty referred and/or related components.

PROCEDURES

- 1 Remove engine air filter.
- 2 Remove cable connector from rectifier-regulator (Fig. 1).
- 3 Remove all fuses and elect. contacts from the fuse carrier (Fig. 1).
- 4 Remove fuse carrier (Fig. 1) from fire wall.
- 5 Remove blade connector from cable connector position C and cut off, insulate and tie back wires with insulating tape.
- 6 Remove blade connectors from cable connector positions R and B, discard cable.
- 7 Modify fuse carrier according to Fig.2 and reinstall fuse carrier in origin location to fire wall.
- 8 Connect rectifier-regulator bridge to cable connector, positions R, B and C.
- 9 Install fuses to safety carrier: - Upper right 30 A - Lower right 30 A - Upper left 10 A - Lower left 125 A
- 10 Connect ring-eye cable connectors to fuse box:
- 11 Outer upper right: Rectifier-regulator bridge
- 12 Middle lower right: Battery hot (L+) cable
- 13 Outer lower right: Cockpit
- 14 Outer lower left: Magneto switch
- 15 Outer upper left: Capacitor / fuel pump I
- 16 Middle lower left: Relay (red / long) 4 mm²
- 17 Middle upper right: Relay (red / short) 4 mm²
- 18 Middle upper left:
- 20 Screw relay on the upper left attachment bolt of the engine mount (just above the fuse carrier / use attachment gear from 24-00-00-S-36780). Relay contacts must face downwards (Fig. 3)
- 21 Connect the black wire of the capacitor to the upper rectifier-regulator foot.
- 22 Connect wires to relay as follows:

- 23 86:Fuel pumps wiring harness (black)
- 24 85 Fuel pumps wiring harness (blue)
- 25 30: Fuse carrier, middle upper right: (red / short) 4 mm²
- 26 87 Fuse carrier, middle lower left (red / long) 4 mm²
- 27 Route fuel pumps wiring harness above the fuse carrier and behind the engine mount down to the fuel pumps.
- 28 Secure capacitor with cable ties and spacers to fuel hose and engine mount. CAUTION: Capacitor must not touch directly the fuel hose! (Fig. 4)
- 29 Reconnect cable connector to rectifier-regulator.
- 30 Disconnect the old fuel pumps wiring harness from fuel pumps P1, P2, disconnect the yellow connector, remove pump wiring harness.
- 31 Connect the blue/white and respective black wire of the fuel pump wiring harness to fuel pump P2 (upper pump) and connect the red and respective black wire of the fuel pump wiring harness to fuel pump P1 (lower pump). Secure electrical contacts of both fuel pumps with securing paint.
- 32 Connect yellow cable connector of fuel pump wiring harness (Fig. 5 - 3)
- 33 Secure fuel pump wiring harness with cable ties and spacers.
- 34 Reinstall engine air filter.

PARTS LIST

Fig.	Pos.	Description	PC PIT	Remark
1	1	Conversion Kit 914 - P1 to charge controller	L2 24-00-00-S-36780	

ILLUSTRATIONS



Fig. 1 - Cable connector on rectifier-regulator (1) and fuse carrier (2)



Fig. 2 – Modified fuse carrier



Fig. 3 – Attachment of the relay



Fig. 4 – Secured capacitor

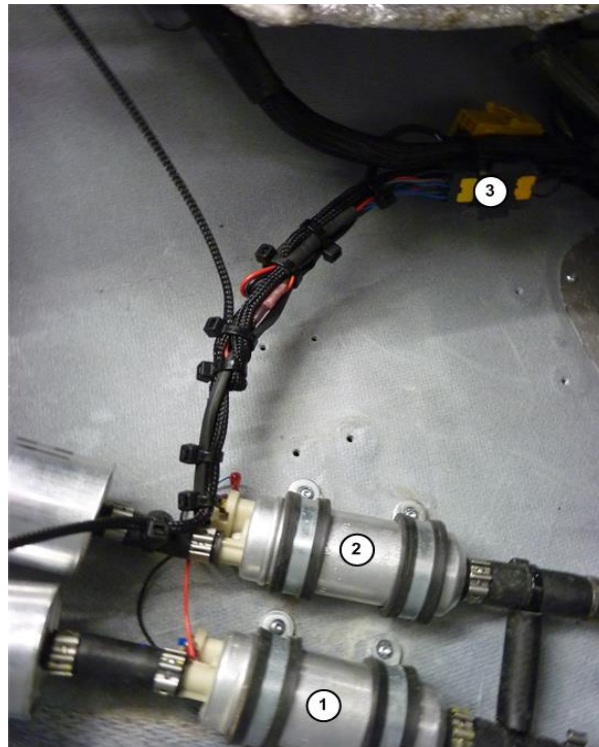

Fig. 5 – Fuel pumps P1 / P2 and cable connector of fuel pump wiring harness

25-60-00 0-1 DESCRIPTION: EMERGENCY LOCATOR TRANSMITTER (ELT)

HVY

GENERAL, REFERENCES AND REQUIREMENTS

Task may only be performed by an organization trained and entitled to carry out 'Heavy Maintenance'!

SPECIAL TOOLS AND CONSUMABLE MATERIALS

CMM Refer to the component/device manufacturer's documentation.

PRECAUTIONS AND SAFETY MEASURES

Refer to the component/device manufacturer's documentation!

PROCEDURES

CAUTION: Device may only be tested with proper testing equipment. Intentional activation for testing without proper testing equipment will lead to false alarms which may initiate an expensive search and rescue alarm chain.

ILLUSTRATIONS

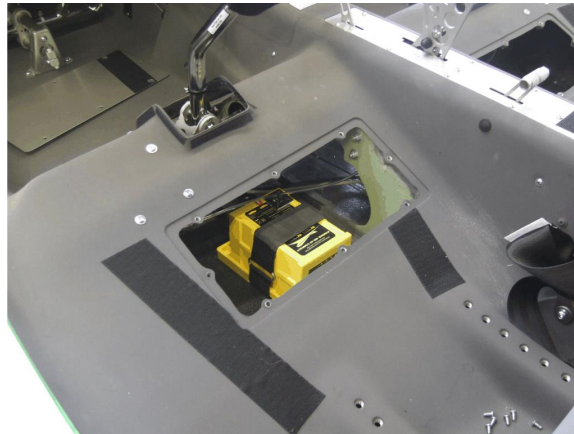

Fig. 1 - Installation Position ELT

26-00-00 0-1 DESCRIPTION: FIRE INDICATING SYSTEM

HVY

GENERAL, REFERENCES AND REQUIREMENTS

SPECIAL TOOLS AND CONSUMABLE MATERIALS

PRECAUTIONS AND SAFETY MEASURES

PROCEDURES

ILLUSTRATIONS

Indicator Light	System Status
OFF	Normal Operation (normal resistance)
FLASHING	Fire, abnormal temperature (circuit short-closed)
ON	System Malfunction (circuit open)

Tbl. 1 - Indication Logic

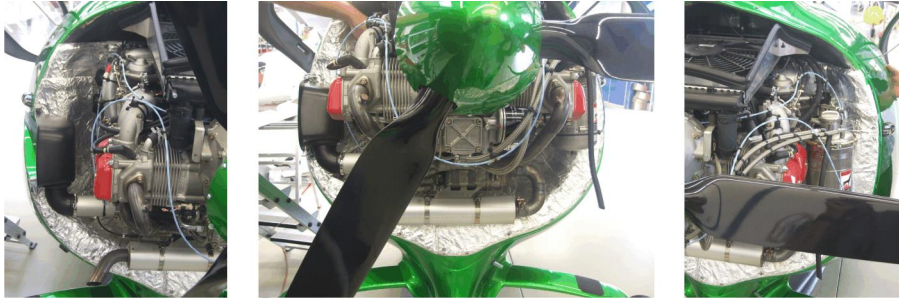

Fig. 2 - Installation - seen from behind



Fig. 3 - Installation - seen from LH side



Fig. 4 - Installation - seen from RH side



Fig. 5 - Installation (detail)

27-10-00 5-1 CHECK-ADJUSTMENT: ROLL CONTROL TRAVEL LIMITATION

LNE

GENERAL, REFERENCES AND REQUIREMENTS

Task may only be performed by an organization or individual trained and entitled to carry out 'Line Maintenance'!

Secure gyroplane against unauthorized or unintended operation!

Rotor system must be removed, see [62-11-00 4-1](#)

Service cover for control linkage must be removed, see [52-40-00 0-1](#).

SPECIAL TOOLS AND CONSUMABLE MATERIALS

88-00-00-S-33588 Screw Securing and Thread-Sealing Varnish yellow

PRECAUTIONS AND SAFETY MEASURES

WARNING: Job includes work at critical flight controls. Duplicate inspection must be performed after completion!

CAUTION: Failure to comply with this instruction will cause the loss of warranty referred and/or related components.

PROCEDURES

- 1 Release brake pressure from rotor head by switching the pneumatic mode selector to 'flight'. If necessary switch between 'brake' and 'flight' several times to release brake pressure completely.

NOTE: Procedure will only be successful by checking and adjusting with flight control sticks in neutral pitch position.

Check

- 2 Move and hold control sticks in fully left position so that left gimbal head stop is reached.
- 3 Measure gap at the base control unit between stop screw and ball joint on pilot side (RH), gap must be 2 mm.
- 4 Move and hold control sticks in fully right position so that right gimbal head stop is reached.
- 5 Measure gap at the base control unit between stop screw and ball joint on passenger side (LH), gap must be 2 mm.

Adjustment

- 6 Move and hold control sticks in fully left position so that left gimbal head stop is reached.
- 7 Untighten counter nut of the stop screw at the base control unit on pilot side (RH). Adjust stop screw until gap between stop screw and ball joint is 2 mm.
- 8 Counter-tighten the counter nut to the stop screw to fix the adjustment.
- 9 Apply screw securing varnish to stop screw thread, counter nut and base control link to seal the fixed adjustment.
- 10 Move and hold control sticks in fully right position so that right gimbal head stop is reached. Repeat steps 7 – 9 on the passenger side (LH).

27-20-00 5-1 CHECK-ADJUSTMENT: RUDDER CONTROL ANGLES

LNE

GENERAL, REFERENCES AND REQUIREMENTS

Task may only be performed by an organization or individual trained and entitled to carry out 'Line Maintenance'!
Secure gyroplane against unauthorized or unintended operation!

SPECIAL TOOLS AND CONSUMABLE MATERIALS

PRECAUTIONS AND SAFETY MEASURES

PROCEDURES

NOTE: Measure points are aft rudder edge and left/right radius between stabilizer and vertical outer fins.

- 1 Adjust pedals in neutral position
 - Note that the nose wheel should be pointed 3° to the left with pedals neutral.**
- 2 Check/adjust N1 = 900 mm (+/- 10 mm) and N2 = 840 mm (+/- 10 mm). See Fig. 1 for reference.
- 3 Press full left pedal (with nose wheel slightly unloaded for ease of movement) and check/adjust L = 630 mm (+/- 50 mm). See Fig. 1 for reference.
- 4 Press full right pedal (with nose wheel slightly unloaded for ease of movement) and check/adjust R = 530 mm (+/- 50 mm). See Fig. 1 for reference.
- 5 Check push-pull control cables (threaded articulation rods) tight and secure.

ILLUSTRATIONS

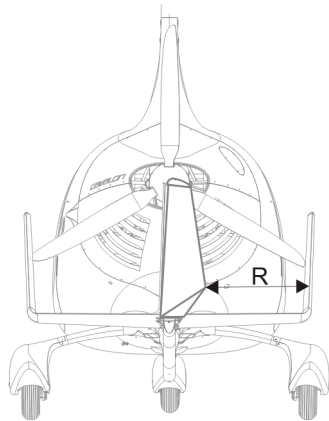
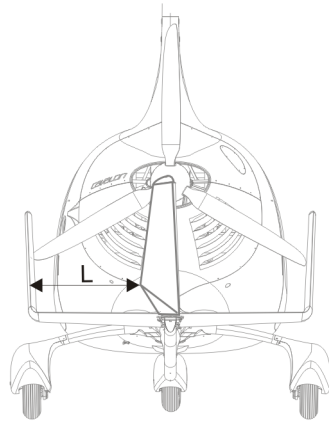
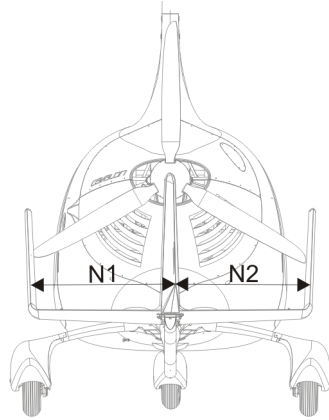

Fig. 1 - Rudder control angle setting



Fig. 2 - Measurement Procedure (example)

28-20-00 6-1 INSPECTION: FUEL FILTER

LNE

GENERAL, REFERENCES AND REQUIREMENTS

Task may only be performed by an organization or individual trained and entitled to carry out 'Line Maintenance'!

Engine cowlings must be removed, see [52-00-00 4-1](#)

Fire wall must be removed, see [71-30-00 4-1](#)

SPECIAL TOOLS AND CONSUMABLE MATERIALS

SP **IMPORTANT NOTE:** Procedure involves spare parts. Check parts list below for ordering details of affected components!

PRECAUTIONS AND SAFETY MEASURES

WARNING: Fuel and fuel vapors are **HAZARDOUS MATERIAL**, must be treated and handled accordingly, and constitute a danger to health and hardware!

IMPORTANT NOTE: Depending on engine variant and optional equipment, number and type of installed fuel filters may differ!

PROCEDURES

EFFECTIVITY: Engine variant ROTAX 912 (without second fuel pump P2)

- 1 Perform a visual inspect on nylon filter.
- 2 If contamination is found, nylon fuel filter must be replaced, see [28-20-00 8-1](#).

EFFECTIVITY - END

EFFECTIVITY: Engine variant ROTAX 912 with second fuel pump P2

NOTE: Fuel system consists of one nylon filter upstream of the mechanical fuel pump, a (secondary) electrical fuel pump with built-in strainer and another filter (KL145) downstream

- 3 Perform a visual inspect on nylon filter.
- 4 If contamination is found or in case of scheduled replacement, nylon fuel filter AND KL145 must be replaced, see [28-20-00 8-1](#) and strainer in electrical fuel pump must be inspected.
- 5 In order to do so, clamp both fuel lines to prevent fuel from spilling and disconnect incoming (lower) fuel line.
- 6 Carefully remove strainer from electrical fuel pump and inspect.
- 7 Clean strainer if necessary. Use brake cleaner and compressed air applied from the outside.
- 8 In case of residual contamination or damage, strainer has to be replaced, see [28-20-00 8-1](#).

EFFECTIVITY - END

EFFECTIVITY: Engine variant ROTAX 914

NOTE: Fuel system consists of two electrical fuel pumps with built-in strainer, each preceded by a filter (KL145) downstream

- 9 Inspect strainer for both electrical fuel pumps. In order to do so, refer to [28-20-00 8-1](#).
- 10 In case of residual contamination or damage, strainer has to be replaced, see [28-20-00 8-1](#).
- 11 In any case, both KL145 filters must be replaced, see [28-20-00 8-1](#).

EFFECTIVITY - END

PARTS LIST

Fig.	Pos.	Description	PC PIT	Remark
1	1	Nylon fuel filter KL 23	L1 73-00-00-V-20575	
1	2	Filter KL 145	L1 73-00-00-V-20581	
1	3	Fuel Pump 912	L1 73-00-00-V-30199	
1	4	fuel pump 914 serialised	L1 73-00-00-S-31394	

ILLUSTRATIONS

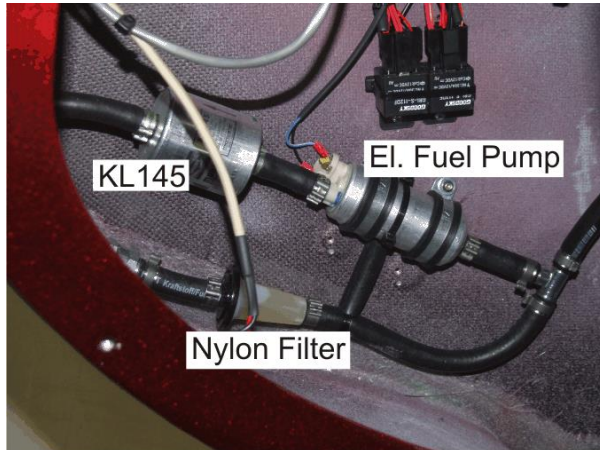

Fig. 1 - Fuel pumps and filters (detail)

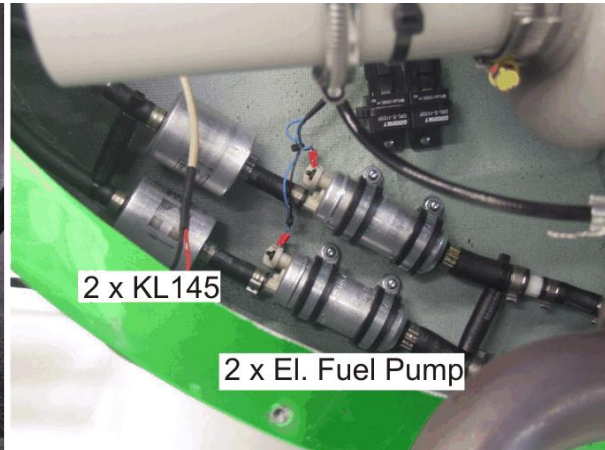

Fig. 2 - Fuel pumps and filters (detail)

28-20-00 8-1 REPLACEMENT: FUEL FILTER

LNE

GENERAL, REFERENCES AND REQUIREMENTS

Task may only be performed by an organization or individual trained and entitled to carry out 'Line Maintenance'!

Engine cowlings must be removed, see [52-00-00 4-1](#)

Fire wall must be removed, see [71-30-00 4-1](#)

SPECIAL TOOLS AND CONSUMABLE MATERIALS

SP **IMPORTANT NOTE:** Procedure involves spare parts. Check parts list below for ordering details of affected components!

PRECAUTIONS AND SAFETY MEASURES

WARNING: Fuel and fuel vapors are HAZARDOUS MATERIAL, must be treated and handled accordingly, and constitute a danger to health and hardware!

PROCEDURES

NOTE: Depending on engine variant and optional equipment, number/type of installed fuel filters may differ

1 CAUTION: Before disconnecting any fuel lines, clamp respective hoses to prevent fuel spillage.

Applicable to Nylon Filter and KL145

- 2 Disconnect filter and replace with new filter.
- 3 Re-connect hoses to filter and make sure tight fit (no leaks, dry).
- 4 Remove clamps from fuel hoses.

PARTS LIST

Fig.	Pos.	Description	PC PIT	Remark
1	1	Nylon fuel filter KL 23	L1 73-00-00-V-20575	
1	2	Filter KL 145	L1 73-00-00-V-20581	
1	3	Fuel Pump 912	L1 73-00-00-V-30199	
1	4	fuel pump 914 serialised	L1 73-00-00-S-31394	

ILLUSTRATIONS

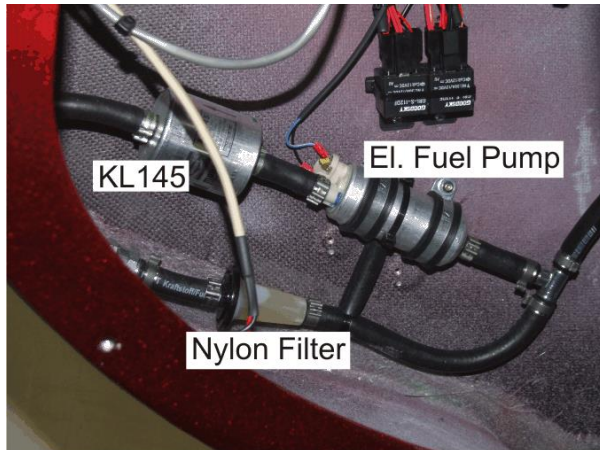

Fig. 1 - Fuel pumps and filters (detail)

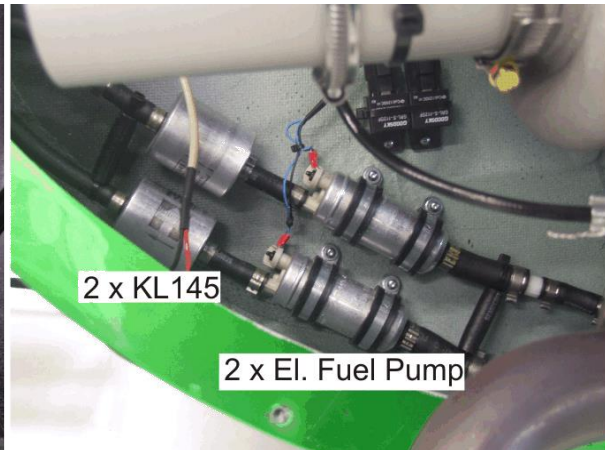

Fig. 2 - Fuel pumps and filters (detail)

28-20-00 8-2 REPLACEMENT: ELECTRICAL FUEL PUMPS

LNE

GENERAL, REFERENCES AND REQUIREMENTS

Task may only be performed by an organization or individual trained and entitled to carry out 'Line Maintenance'!

Secure gyroplane against unauthorized or unintended operation!

Engine cowlings must be removed, see [52-00-00 4-1](#)

Fire wall must be removed, see [71-30-00 4-1](#)

SPECIAL TOOLS AND CONSUMABLE MATERIALS

SP **IMPORTANT NOTE:** Procedure involves spare parts. Check parts list below for ordering details of affected components!

PRECAUTIONS AND SAFETY MEASURES

WARNING: Fuel and fuel vapors are HAZARDOUS MATERIAL, must be treated and handled accordingly, and constitute a danger to health and hardware!

PROCEDURES

WARNING: Make sure the electrical system is switched off and protected against unintended activation

- 1 Clamp respective hoses to prevent fuel spillage.
- 2 Unscrew both terminal nuts and disconnect both ring eye cable connectors. Isolate blank connectors to prevent electrical short-cut.
- 3 Disconnect fuel lines from pump.
- 4 Untighten attachment hardware and replace fuel pump.
- 5 Install new fuel pump and tighten attachment hardware.

IMPORTANT NOTE: The electrical terminals of the pump and the ring-eye cable connectors have different diameters to ensure correct polarization

- 6 Re-connect electrical cable connectors and tighten terminal nuts. Secure terminal nuts with securing paint.
- 7 Re-connect hoses to pump and make sure tight fit.
- 8 Remove clamps from fuel hoses.
- 9 Activate respective fuel pump and check function and proper fuel line connection (no leaks, dry).

PARTS LIST

Fig.	Pos.	Description	PC PIT	Remark
1	1	Fuel Pump 912	L1 73-00-00-V-30199	ROTAX 912
1	2	fuel pump 914	L1 73-00-00-S-31395	ROTAX 914

ILLUSTRATIONS

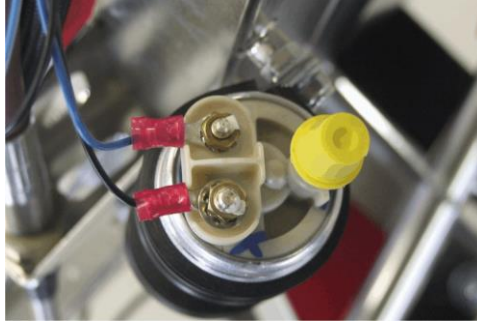

Fig. 1 - El. fuel pump terminal (detail)

32-10-00 8-1 REPLACEMENT: MAIN GEAR SUSPENSION BOW ATTACHMENT BOLTS

HVY

GENERAL, REFERENCES AND REQUIREMENTS

Task may only be performed by an organization trained and entitled to carry out 'Specialized Level Tasks'!
Secure gyroplane against unauthorized or unintended operation!

SPECIAL TOOLS AND CONSUMABLE MATERIALS

None

PRECAUTIONS AND SAFETY MEASURES

MANUFACTURER RECOMMENDATION: *Fuel tanks should be defueled before starting task!*

WARNING: *Fuel and fuel vapors are HAZARDOUS MATERIAL, must be treated and handled accordingly, and constitute a danger to health and hardware!*

PROCEDURES

- 1 Remove main gear suspension bow cover (Fig. 1, 1).
- 2 Open service cover (Fig. 1, 2).
- 3 Untighten and remove bolt (Fig. 2, 1).
- 4 Clamp 10 mm drill bit into appropriate drill machine and equip drill bit with washers in order to avoid damaging the fuel tank (Fig. 3).
WARNING: Do not damage or even puncture fuel tank!
- 5 Drill up the 8 mm drill hole with drill and with washers equipped 10 mm – drill bit (Fig. 4).
EFFECTIVITY: up to S/N (Werk-Nr.) V00089
- 6 Equip bolt M 10 x **100** with washer U10/30 and insert bolt M 10 x **100** into drill hole, place washer U10/30 and M10 self-locking nut and hand tighten through the service opening.
EFFECTIVITY: S/N (Werk-Nr.) V00090 and subsequent
- 7 Equip bolt M 10 x **90** with washer U10/30 and insert bolt M 10 x **90** into the hole, place washer U10/30 and M10 self-locking nut and hand tighten through the service opening.
- 8 Repeat work steps 3 - 6 with second bolt (Fig. 2, 2).
- 9 Torque-tighten bolts (Fig. 2, 1 and 2) with 35 Nm.
- 10 Perform tool and loose-article check in service opening and close service cover.
- 11 Install gear suspension bow cover.

PARTS LIST

Fig.	Pos.	Description	PC	PIT	Remark
		attachmt. kit for undercarriage	L2	32-00-00-S-34611	

ILLUSTRATIONS

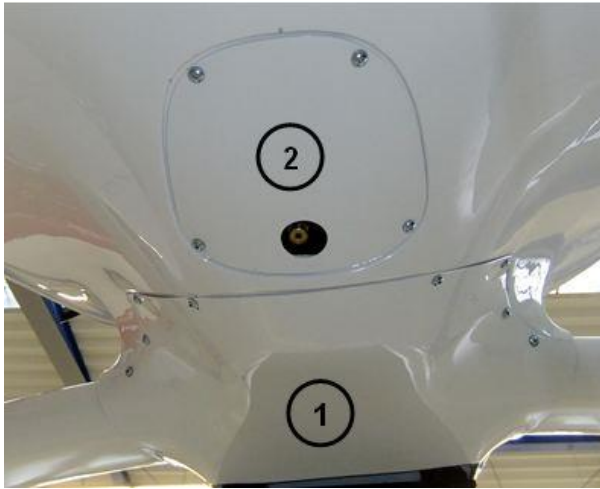

Fig. 1 - Main gear suspension bow cover and service cover

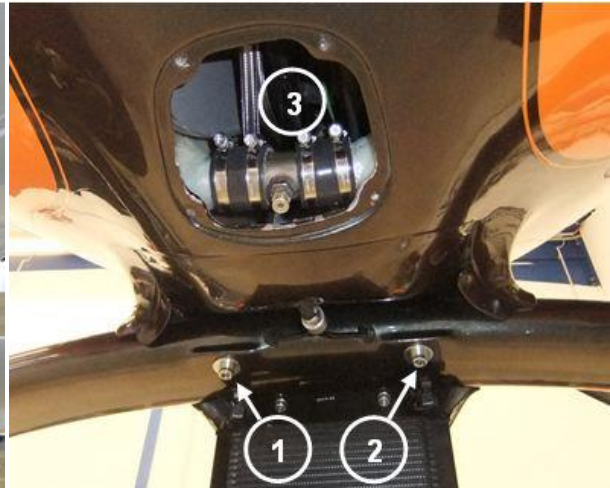

Fig. 2 - Main gear suspension bow



Fig. 3 - 10 mm drill bit equipped with washers



Fig. 4 - Drilling to a diameter of 10 mm

32-20-00 8-1 REPLACEMENT: NOSE GEAR RUBBER DAMPER

LNE

GENERAL, REFERENCES AND REQUIREMENTS

Task may only be performed by an organization or individual trained and entitled to carry out 'Line Maintenance'!

Gyroplane must be jacked, see [07-00-00 2-2](#)

SPECIAL TOOLS AND CONSUMABLE MATERIALS

AG-BAS-02 Loctite 243 blue (88-00-00-S-30483)

AG-GRS-01 Lagermeister WHS 2002 Grease (88-00-00-S-30477)

PRECAUTIONS AND SAFETY MEASURES

PROCEDURES

- 1 Remove bolt (1) and washer (2).
- 2 Pull control linkage (3) from square shaft. Caution: Hold wheel assembly and prevent from falling out. Discard O-ring (4)!
- 3 Pull out front wheel assembly. Note that bushings (5) and (7) remain in the fuselage.
- 4 Remove rubber damper (8).
- 5 Install new rubber damper.
- 6 Apply AG-GRS-01 on the tube, but not on the threads. Install nose wheel assembly in reverse order. Make sure wheel assembly is installed so that angled fork faces forward, i.e. extends to the front.
- 7 Install new O-ring (4).
- 8 Install control linkage (3) and washer (2).
- 9 Apply AG-BAS-02 to inner threads of nose gear assembly and install bolt (1).
- 10 Torque-tighten bolt (1) with 40 Nm.

PARTS LIST

Fig.	Pos.	Description	PC PIT	Remark
1	1	M10x20	NPI	
1	2	U11x34x3	NPI	
1	3	nose wheel steering	NPI	
1	4	O-Ring 30x5	NPI	
1	5	steering bush	L2 32-00-00-V-22169	
1	6	nosewheel fork long welded	NPI	
1	7	steering bush	L2 32-00-00-V-22169	
1	8	shock absorber 2,5	NPI	
1	9	Nose wheel spat nosewheel painted	L1 53-00-00-V-32070	
1	10	M6x12 round head	NPI	
1	11	U6/18	NPI	
1	12	M10, Si	NPI	
1	13	U10	NPI	
1	14	Nosewheel axle M10x155 DIN 912	NPI	
1	15		32-00-00-V-31914	

ILLUSTRATIONS

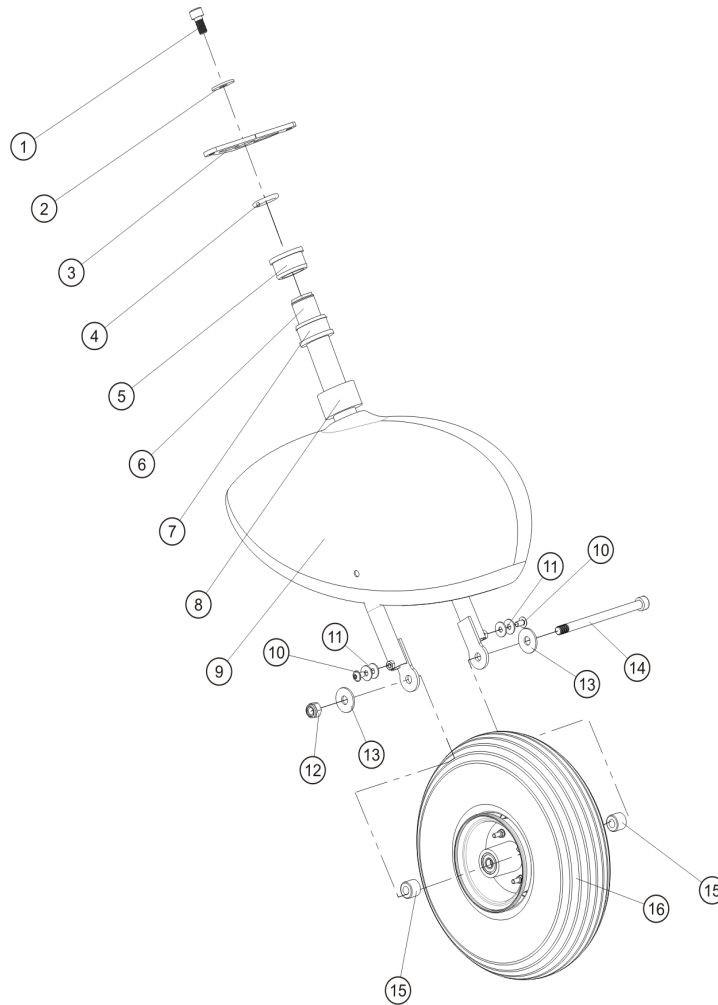

Fig. 1 - Nose gear assembly

32-40-00 4-1 REMOVAL-INSTALLATION: WHEELS

LNE

GENERAL, REFERENCES AND REQUIREMENTS

Task may only be performed by an organization or individual trained and entitled to carry out 'Line Maintenance'!

Gyroplane must be jacked, see [07-00-00 2-2](#)

SPECIAL TOOLS AND CONSUMABLE MATERIALS

AG-BAS-02 Loctite 243 blue (88-00-00-S-30483)

LR **IMPORTANT NOTE:** Procedure involves parts with limited reusability. Check parts list below before starting job!

PRECAUTIONS AND SAFETY MEASURES

PROCEDURES

Nose wheel - Removal

NOTE: If no assembly hole is present in wheel spat it is recommended to drill a hole through which the bolt can be removed. Otherwise, the wheel spat must be removed.

- 1 Unscrew and remove nut (Fig.1, 12) and washer (Fig.1, 13). Discard nut.
- 2 Pull out and remove bolt (Fig.1, 14) with washer (Fig.1, 13) and remove wheel. Maintain spacers (Fig.1, 15)!

Nose wheel - Installation

- 3 Install wheel with spacers (Fig.1, 15) in place, bolt (Fig.1, 14) with washers (Fig.1, 13) in reverse order.
- 4 Install new self-locking nut (Fig.1, 12) and torque-tighten with 35 Nm.
- 5 Install plug in assembly hole, if required.

Main wheel - Removal

- 6 Remove wheel spat (if installed).
- 7 Remove and discard split pin (Fig. 3, 5) and unscrew the castellated nut (Fig.3, 18). Discard split pin (Fig. 3, 5).
- 8 Unscrew and remove 4 x bolt (Fig. 3, 3) with serrated washer (Fig. 3, 4). Mind limited reusability of serrated washer!
- 9 Remove wheel from axle assembly (Fig. 3, 7/9).

Main wheel - Installation

- 10 Insert main wheel on axle assembly (Fig. 3, 7/9).
- 11 Insert 4 x bolt (Fig. 3, 3) with new serrated washer (Fig. 3, 4) and attach brake disc to main wheel.
- 12 Torque-tighten bolts (Fig. 3, 3) with 10 Nm in crosswise sequence.
- 13 Install castellated nut (Fig. 3, 18) and torque-tighten nut with 35 Nm.
- 14 Install split pin (Fig. 3, 5).
- 15 Check free rotation of wheel, radial run-out and braking action.
- 16 Install wheel spat, if required.

PARTS LIST

Fig.	Pos.	Description	PC	PIT	Remark
1	1	M10x20		NPI	
1	2	U11x34x3		NPI	

1	3	nose wheel steering	NPI
1	4	O-Ring 30x5	NPI
1	5	steering bush	L2 32-00-00-V-22169
1	6	nosewheel fork long welded	NPI
1	7	steering bush	L2 32-00-00-V-22169
1	8	shock absorber 2,5	NPI
1	9	Nose wheel spat nosewheel painted	L1 53-00-00-V-32070
1	10	M6x12 round head	NPI
1	11	U6/18	NPI
1	12	M10, Si	NPI
1	13	U10	NPI
1	14	Nosewheel axle M10x155 DIN 912	NPI
1	15		32-00-00-V-31914
3	1		53-00-00-V-32781
3	2		53-00-00-V-32781
3	3	M6x12 round head	L1 32-40-00-V-30004
3	4	Safety washer M6	L1 32-40-00-V-30004
3	5	Split pin 3.2x40	L1 32-00-00-V-32136
3	6	spacer 26-5/20,2	L1 32-00-00-V-32136
3	7	wheel axis welded	L1 32-00-00-V-32136
3	8	Stop nut M6	L1 32-00-00-V-32136
3	9	brake caliper bracket installed	L1 32-00-00-V-32136
3	10	M6x25 counter sunk	L1 32-00-00-V-32136
3	11	Brake caliber	NPI
3	12	Brake pad outer (small)	L2 32-40-00-V-30512
3	13	Brake Disc	L1 32-40-00-V-30004
3	14	Cylinder bushing 22x10x6	NPI
3	15	Brake pad inner (big)	L2 32-40-00-V-30511
3	16	Safety washer M6	NPI
3	17	M6x40	NPI
3	18	castle nut M18x1	L1 32-00-00-V-32136
3	19	Alu bush Prerotator brake	L1 53-00-00-V-32781
3	20	U6/25 Big washer	L1 53-00-00-V-32781
3	21	M6x60 rounded head	L1 53-00-00-V-32781
4	1	Roller bearing 6204 ZRS	L2 32-00-00-V-20078
4	2	Tube standard	L0 32-00-00-V-26651
4	3	Tyre standard	L0 32-00-00-V-20080
4	4	Rimm installed	L1 32-00-00-V-30595
4	5	Spacer wheel	L1 32-00-00-V-30595
4	6	Roller bearing 6204 ZRS	L2 32-00-00-V-20078

ILLUSTRATIONS

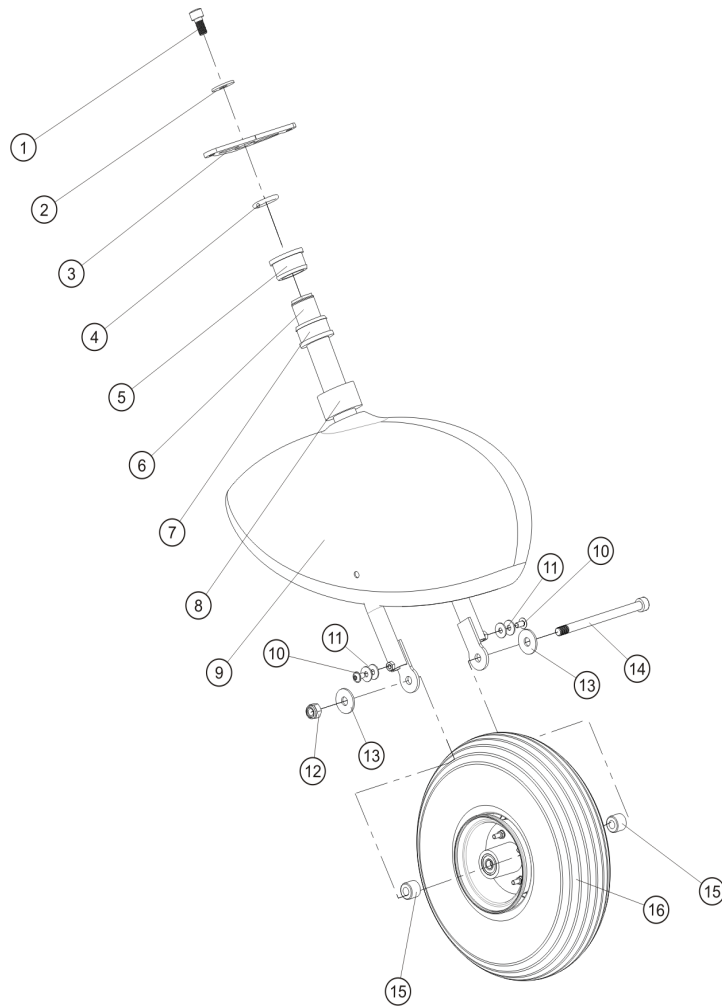

Fig. 1 - Nose gear assembly

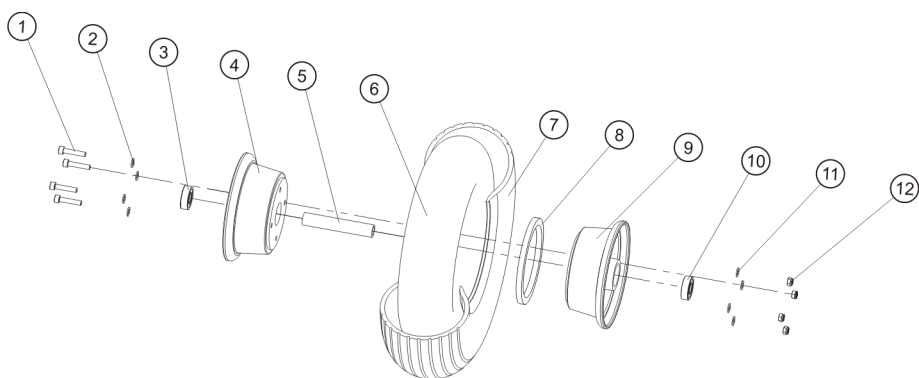

Fig. 2 - Nose wheel

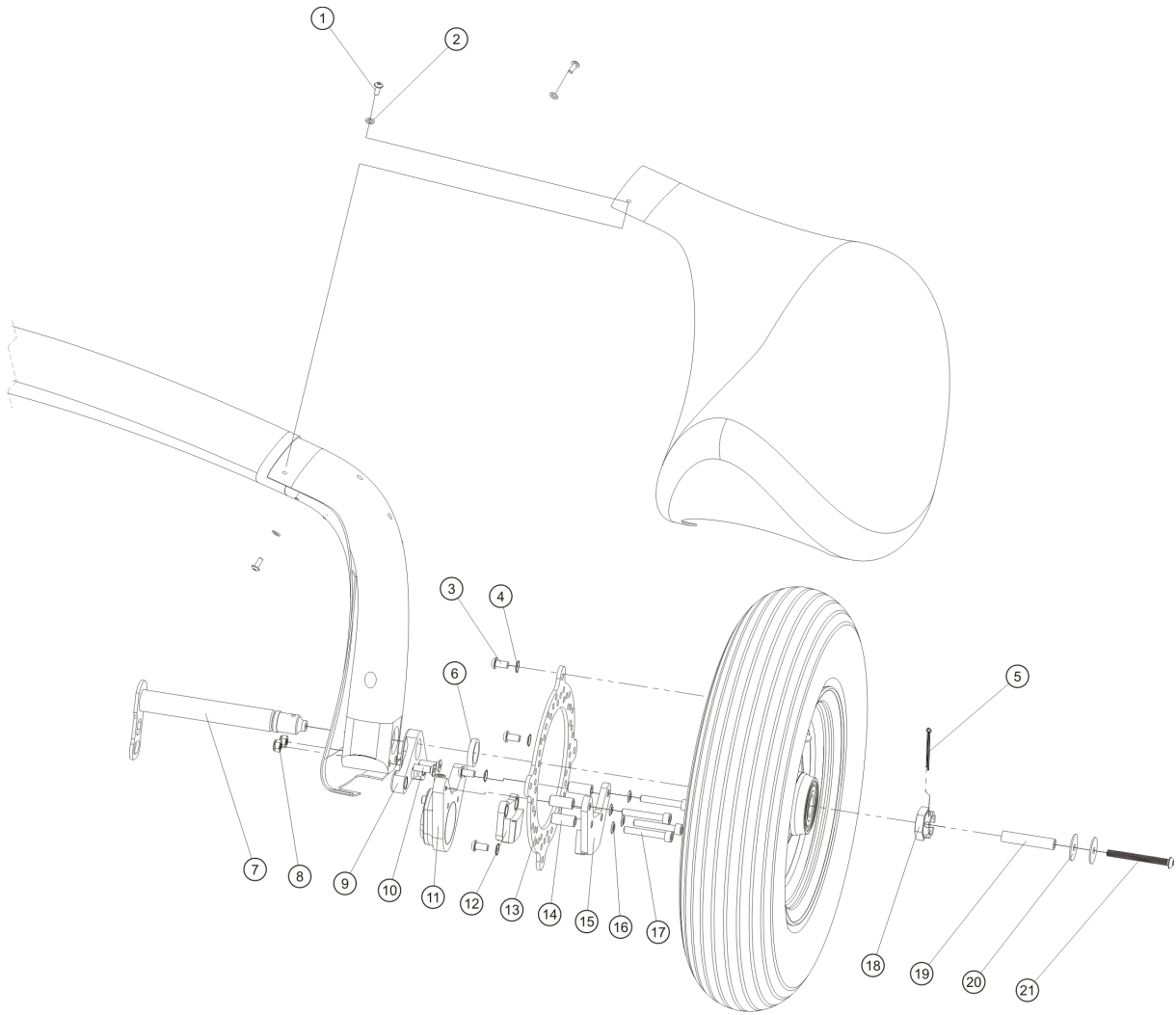

Fig. 3 - Main gear assembly

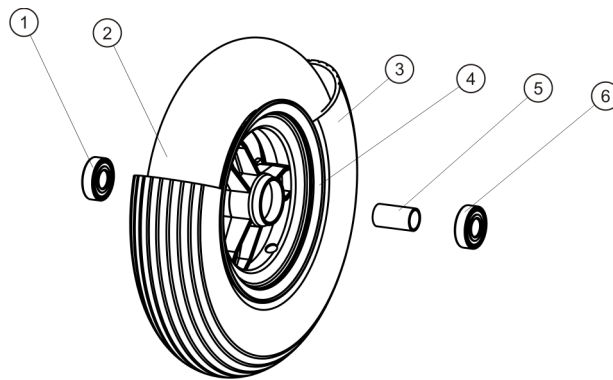

Fig. 4 - Main wheel

32-40-00 8-2 REPLACEMENT: MAIN WHEEL BRAKE PADS

LNE

GENERAL, REFERENCES AND REQUIREMENTS

Task may only be performed by an organization or individual trained and entitled to carry out 'Line Maintenance'!

Gyroplane must be jacked, see [07-00-00 2-2](#)

Affected wheel must be removed, see [32-40-00 4-1](#)

SPECIAL TOOLS AND CONSUMABLE MATERIALS

AG-LUB-04 Silicone Spray (88-00-00-S-30490)

LR IMPORTANT NOTE: Procedure involves parts with limited reusability. Check parts list below before starting job!

SP IMPORTANT NOTE: Procedure involves spare parts. Check parts list below for ordering details of affected components!

PRECAUTIONS AND SAFETY MEASURES

IMPORTANT NOTE: Procedure involves handling and disposal of special materials. For your health and environmental aspects respect all applicable regulations!

PROCEDURES

- 1 Pull out brake disc (13) between brake pads.
- 2 Remove 4 x shaft bolt (17) with serrated washer (16).
- 3 Remove brake pad (12) and (15). Dispose of properly!
- 4 Clean 4 x guide sleeves of axle assembly (14) and inspect for damage, scores or run-in grooves.
- 5 Apply a thin layer of silicone spray on guide sleeves of axle assembly.
- 6 Fit new brake pad (12) onto lower guide sleeves.
- 7 Fit new brake pad (15) onto upper guide sleeves.
- 8 Insert 4 x shaft bolt (17) with serrated washers (16) and torque-tighten with 10 Nm. Make sure that brake caliper and pad moves easily about the running sleeve.
- 9 Insert brake disc between brake pads.
- 10 In order to re-install wheel continue with [32-40-00 4-1](#).

PARTS LIST

Fig.	Pos.	Description	PC PIT	Remark
1	1		53-00-00-V-32781	
1	2		53-00-00-V-32781	
1	3	M6x12 round head	L1 32-40-00-V-30004	
1	4	Safety washer M6	L1 32-40-00-V-30004	
1	5	Split pin 3.2x40	L1 32-00-00-V-32136	
1	6	spacer 26-5/20,2	L1 32-00-00-V-32136	
1	7	wheel axis welded	L1 32-00-00-V-32136	
1	8	Stop nut M6	L1 32-00-00-V-32136	
1	9	brake caliper bracket installed	L1 32-00-00-V-32136	
1	10	M6x25 counter sunk	L1 32-00-00-V-32136	
1	11	Brake caliber	NPI	
1	12	Brake pad outer (small)	L2 32-40-00-V-30512	
1	13	Brake Disc	L1 32-40-00-V-30004	

1	14	Cylinder bushing 22x10x6	NPI
1	15	Brake pad inner (big)	L2 32-40-00-V-30511
1	16	Safety washer M6	NPI
1	17	M6x40	NPI
1	18	castle nut M18x1	L1 32-00-00-V-32136
1	19	Alu bush Prerotator brake	L1 53-00-00-V-32781
1	20	U6/25 Big washer	L1 53-00-00-V-32781
1	21	M6x60 rounded head	L1 53-00-00-V-32781

ILLUSTRATIONS

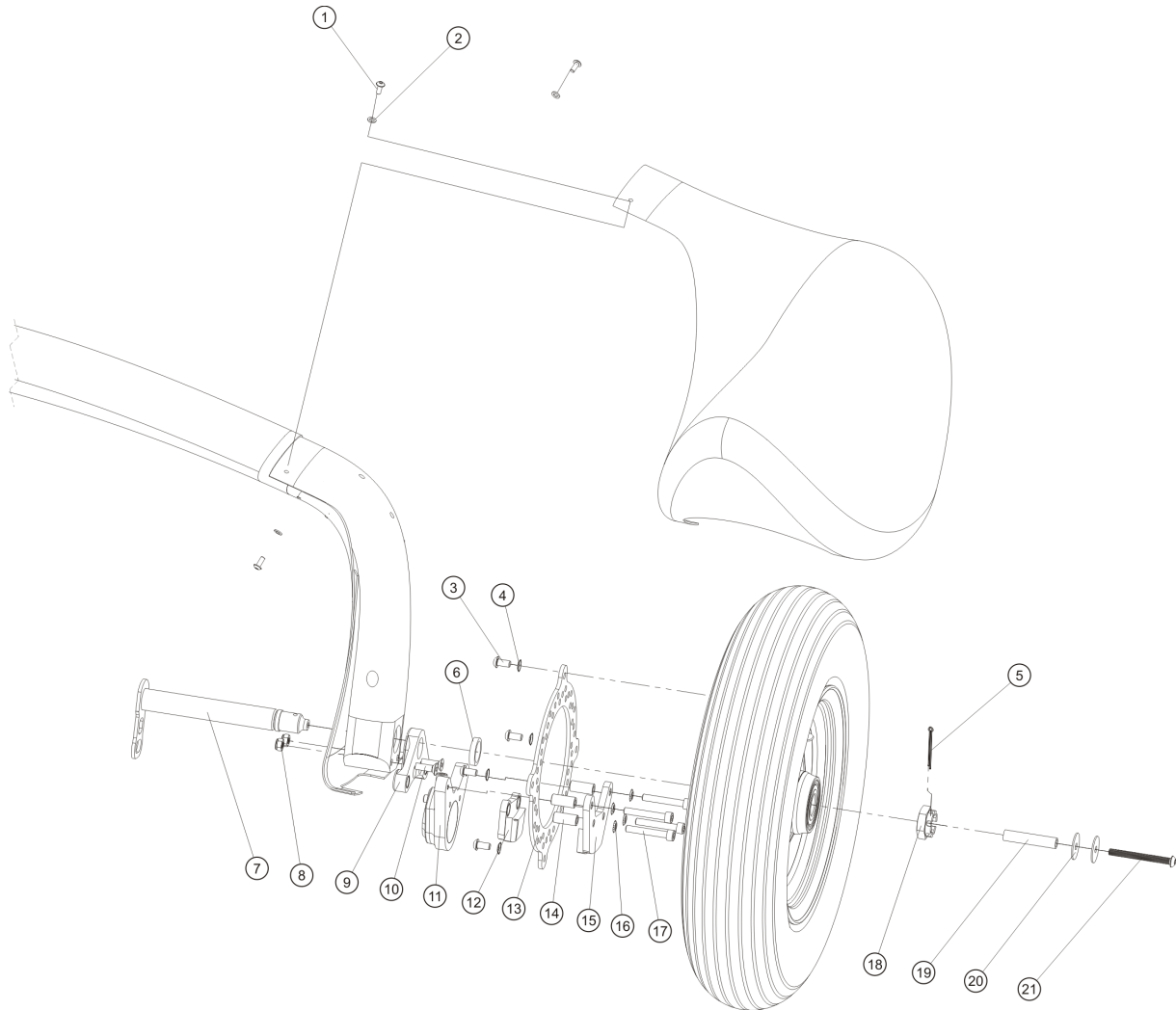

Fig. 1 - Main wheel with brake

32-40-00 8-3 REPLACEMENT: WHEEL BEARING

HVY

GENERAL, REFERENCES AND REQUIREMENTS

Task may only be performed by an organization trained and entitled to carry out 'Heavy Maintenance'!

Gyroplane must be jacked, see [07-00-00 2-2](#)

Affected wheel must be removed, see [32-40-00 4-1](#)

SPECIAL TOOLS AND CONSUMABLE MATERIALS

ContactAG For special tools or assistance contact AutoGyro customer support

PRECAUTIONS AND SAFETY MEASURES

PROCEDURES

- 1 Perform work according to exploded views.

PARTS LIST

Fig.	Pos.	Description	PC PIT	Remark
2	1	Roller bearing 6204 ZRS	L2 32-00-00-V-20078	
2	2	Tube standard	L0 32-00-00-V-26651	
2	3	Tyre standard	L0 32-00-00-V-20008	
2	4	Rimm installed	L1 32-00-00-V-30595	
2	5	Spacer wheel	L1 32-00-00-V-30595	
2	6	Roller bearing 6204 ZRS	L2 32-00-00-V-20078	

ILLUSTRATIONS

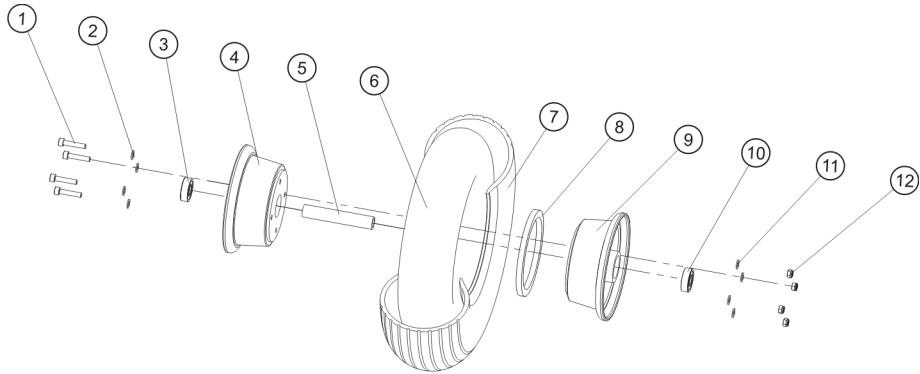

Fig. 1 - Nose wheel

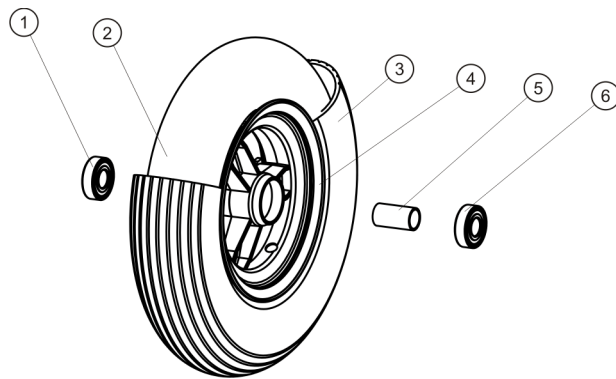

Fig. 2 - Main wheel and bearing

34-10-00 5-1 TEST: PITOT STATIC SYSTEM INTEGRITY

LNE

GENERAL, REFERENCES AND REQUIREMENTS

Task may only be performed by an organization or individual trained and entitled to carry out 'Line Maintenance'!

SPECIAL TOOLS AND CONSUMABLE MATERIALS

ContactAG For special tools or assistance contact AutoGyro customer support

PRECAUTIONS AND SAFETY MEASURES

CAUTION: Instruments can easily be damaged if test is performed improperly. Manipulate test equipment slowly and carefully. Monitor indicators and make sure that indication is always within normal indication range!

PROCEDURES

Pitot System Test

- 1 Pull-out plunger of test equipment for the pitot nozzle (long silicone tube) to read 2 ml.
- 2 Attach test equipment to pitot nozzle.
- 3 Slowly depress plunger to read 1 ml. Airspeed indication must increase significantly.
NOTE: The actual value will depend on the length and cross-section of the pipework installed.
- 4 Leave set-up unchanged and check decay over 10 seconds. Decay should be less than 10% per 10 seconds.
- 5 Gently ease tube off the pitot nozzle. Airspeed indicator(s) must return to zero.
- 6 If any of the preceding tests has failed, have system inspected and repaired.

Static System Test (if installed)

- 7 Block one static port with a strip of tape.
NOTE: Do not use transparent tape as this may be overlooked and forgotten. It is recommended to use red insulating tape with a relatively large extending end.
- 8 Press in plunger of test equipment for the static port (short silicone adapter) completely.
- 9 Press and hold test equipment to the open static port tight to the hole.
- 10 Pull plunger slowly about 3 ml.
- 11 Indicated altitude and airspeed indication must increase.
- 12 If installed, VSI indication must increase momentarily and will slowly fade to zero.
- 13 Leave set-up unchanged and check decay over 10 seconds. There shall be no noticeable decay (except VSI).
- 14 Remove silicone adapter from static port. Altitude must return to initial indication.
- 15 If any of the preceding tests has failed, have system inspected and repaired.

ILLUSTRATIONS



Fig. 1 - Pitot Static Integrity Test Equipment

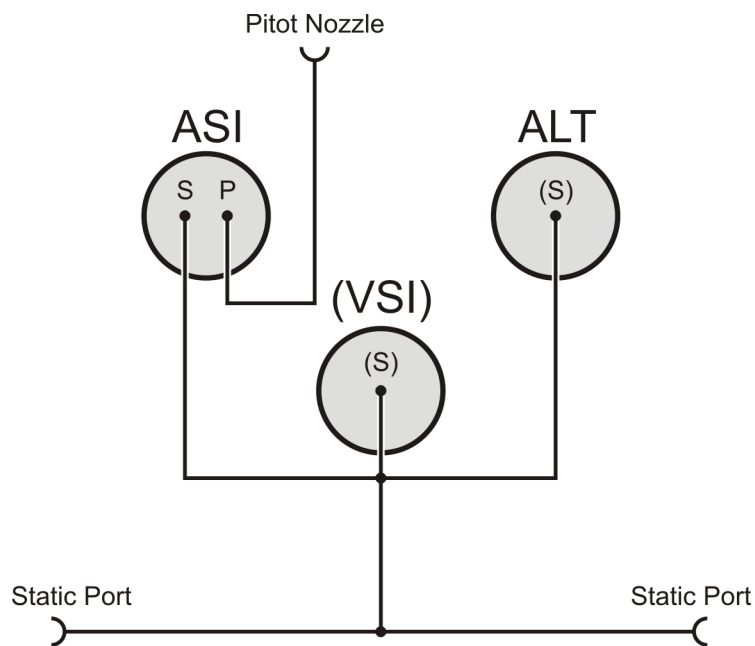

ALT: Altitude Indicator
 ASI: Airspeed Indicator
 VSI: Vertical Speed Indicator (if installed)
 Note:
 Integrated Instruments (Glass Cockpit)
 and backup instruments are also
 connected, if installed.

Fig. 2 - Pitot Static Instruments Connecting Diagram

34-10-00 7-1 CLEANING: PITOT STATIC SYSTEM

LNE

GENERAL, REFERENCES AND REQUIREMENTS

Task may only be performed by an organization or individual trained and entitled to carry out 'Line Maintenance'!
Secure gyroplane against unauthorized or unintended operation!

SPECIAL TOOLS AND CONSUMABLE MATERIALS

PRECAUTIONS AND SAFETY MEASURES

CAUTION: Make sure all pitot and static lines are disconnected from any instruments before blowing through the lines!

CAUTION: Do not blow with the mouth directly into pitot or static ports. This will introduce moisture and may damage instruments!

PROCEDURES

- 1 Disconnect all instruments from pitot and static lines. These are altimeter, airspeed, but also VSI and integrated display systems, if installed.
NOTE: In most cases it is not necessary to remove the instrument panel.
- 2 With the help of compressed air clean all pitot and static lines by blowing from the inside (cockpit panel side) to the outside.
- 3 Make sure to clean/check each branch of a line by closing the other open ends.
- 4 Re-connect all instruments and perform Pitot Static System Integrity Test, see [34-10-00 5-1](#).

ILLUSTRATIONS

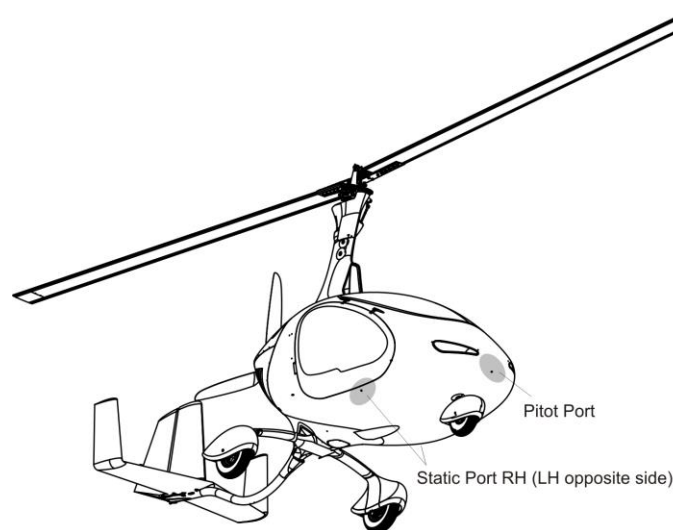
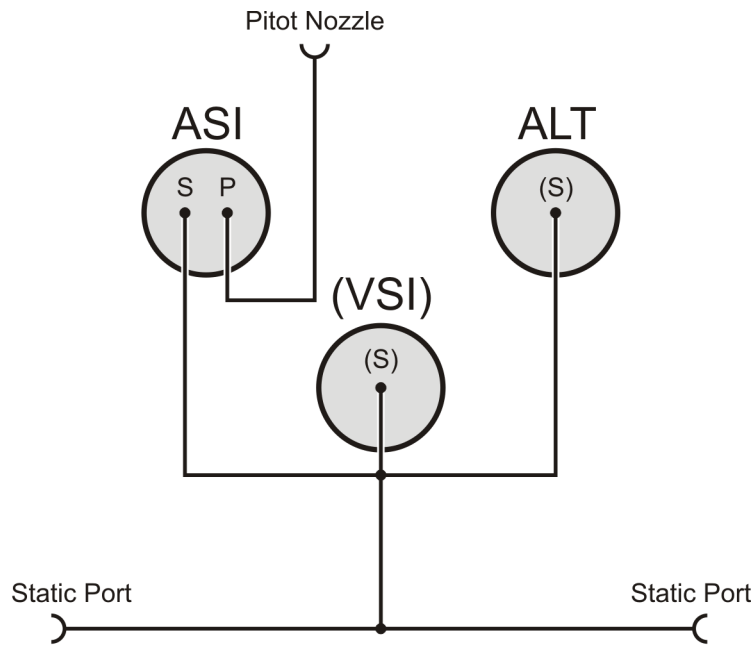

Fig. 1 - Static ports (2 x) and pitot port



ALT: Altitude Indicator
 ASI: Airspeed Indicator
 VSI: Vertical Speed Indicator (if installed)
 Note:
 Integrated Instruments (Glass Cockpit)
 and backup instruments are also
 connected, if installed.

Fig. 2 - Pitot Static Instruments Connecting Diagram

36-21-00 8-1 REPLACEMENT: FILTER/DRYER

LNE

GENERAL, REFERENCES AND REQUIREMENTS

Task may only be performed by an organization or individual trained and entitled to carry out 'Line Maintenance'!

Secure gyroplane against unauthorized or unintended operation!

Engine cowlings must be removed, see [52-00-00 4-1](#)

Fire wall must be removed, see [71-30-00 4-1](#)

SPECIAL TOOLS AND CONSUMABLE MATERIALS

PRECAUTIONS AND SAFETY MEASURES

PROCEDURES

- 1 Unscrew inlet and outlet connection and discard old seal ring (compressor side only).
- 2 Replace filter/dryer with new one and make sure cartridge is tightened safely to rear wall. Install new seal ring.
- 3 Re-connect and tighten inlet and outlet connection with moderate torque.

ILLUSTRATIONS

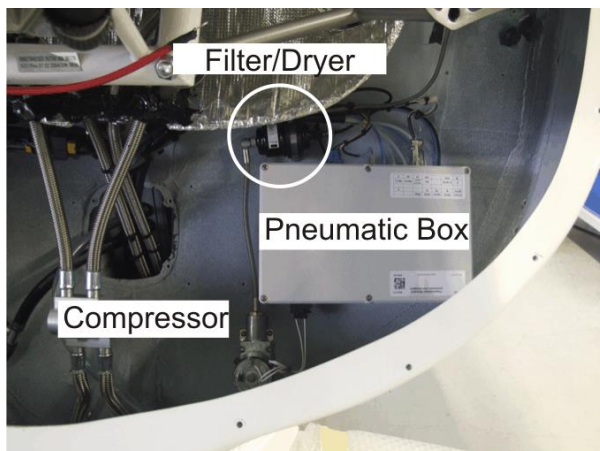

Fig. 1 - Rear wall (installation wall)



Fig. 2 - Filter/dryer

52-00-00 4-1 REMOVAL-INSTALLATION: COWLINGS

OPR

GENERAL, REFERENCES AND REQUIREMENTS

Basic operational task, which can be performed by a licensed pilot or instructed personnel!

Secure gyroplane against unauthorized or unintended operation!

SPECIAL TOOLS AND CONSUMABLE MATERIALS

PRECAUTIONS AND SAFETY MEASURES

PROCEDURES

Upper engine cowling (1) - Removal

- 1 Open all quick lock fasteners using a PH2 screw driver.
- 2 With help of a second person carefully remove upper engine cowling to the top.

Upper engine cowling (1) - Installation

- 3 With the help of a second person bring engine cowling into position.
- 4 Fasten all quick locks fasteners using a PH2 screw driver.

Lower engine cowling (2) - Removal

- 5 Upper engine cowling must be removed!
- 6 Remove all linse head bolts with poly washers and maintain. Make sure not to lose poly washers. The cowling should be held by a second person.
- 7 With the help of a second person remove cowling. Make sure not to damage engine drain hoses.

Lower engine cowling (2) - Installation

- 8 Upper engine cowling must be removed!
- 9 With the help of a second person bring cowling into position. Make sure to insert drain hoses without damage.
- 10 Insert linse head bolts with poly washers and screw in without tightening, preferably working from top to bottom.
- 11 Fasten all bolts with 3 Nm.

Mast cover (3) - Removal

- 12 Remove and maintain linse head bolts with poly washers and remove mast cover.
- 13 Carefully bend open mast cover and slide over the mast to the front.

Mast cover (3) - Installation

- 25 Install mast cover in reverse order (work steps 13 - 12).
- 26 Fasten all bolts with 3 Nm.

ILLUSTRATIONS

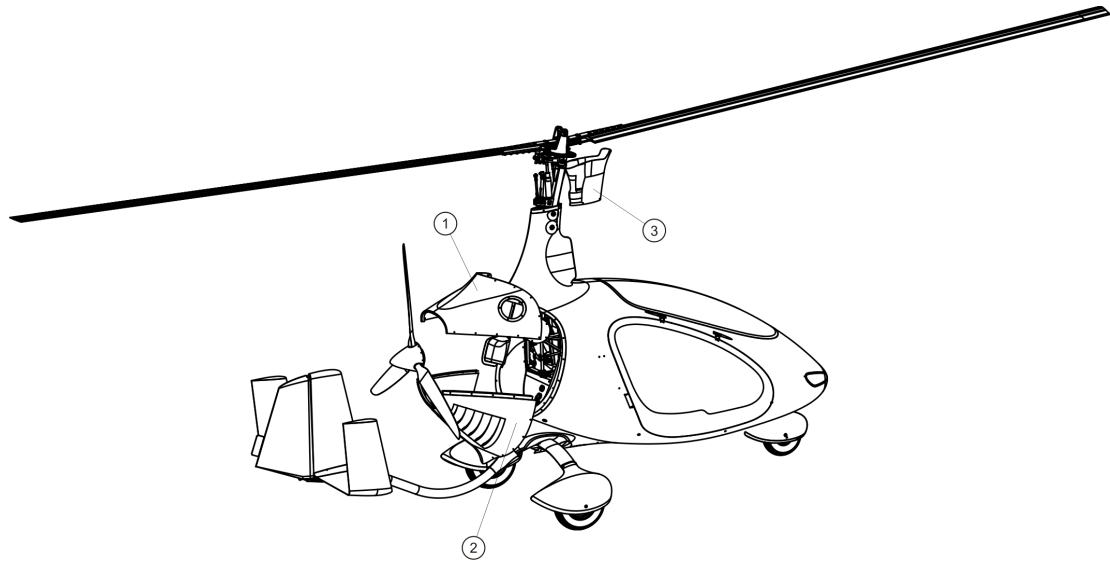

Fig. 1 - Cowling and mast cover

52-40-00 0-1 DESCRIPTION: SERVICE COVERS IN COCKPIT SHELL

LNE

GENERAL, REFERENCES AND REQUIREMENTS

SPECIAL TOOLS AND CONSUMABLE MATERIALS

PRECAUTIONS AND SAFETY MEASURES

PROCEDURES

ILLUSTRATIONS



Fig. 1 - Service covers below seats ('Equipment Cover')

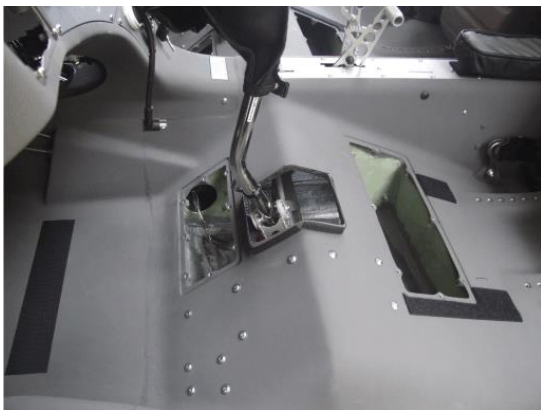

Fig. 2 - Service cover for control linkage (LH) and below seat (RH)

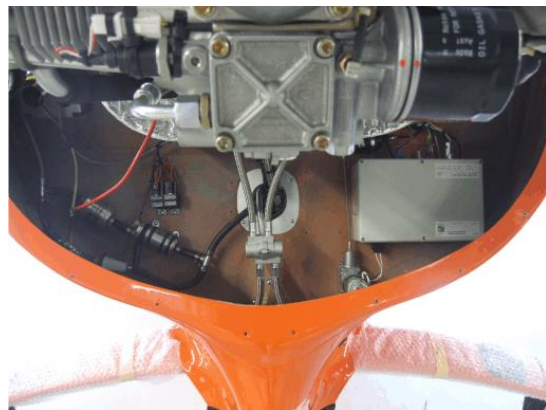

Fig. 3 - Rear Wall 'Installation Wall' (Fire Wall removed)

55-00-00 8-1 REPLACEMENT: KEEL TUBE PROTECTION PAD

LNE

GENERAL, REFERENCES AND REQUIREMENTS

Task may only be performed by an organization or individual trained and entitled to carry out 'Line Maintenance'!
Secure gyroplane against unauthorized or unintended operation!

SPECIAL TOOLS AND CONSUMABLE MATERIALS

AG-BAS-01 Loctite 221 red (88-00-00-S-30487)

SP **IMPORTANT NOTE:** Procedure involves spare parts. Check parts list below for ordering details of affected components!

PRECAUTIONS AND SAFETY MEASURES

PROCEDURES

- 1 Remove 2 x bolt and replace protection pad.
- 2 Apply AG-BAS-01 on threads of bolts an tighten.

ILLUSTRATIONS

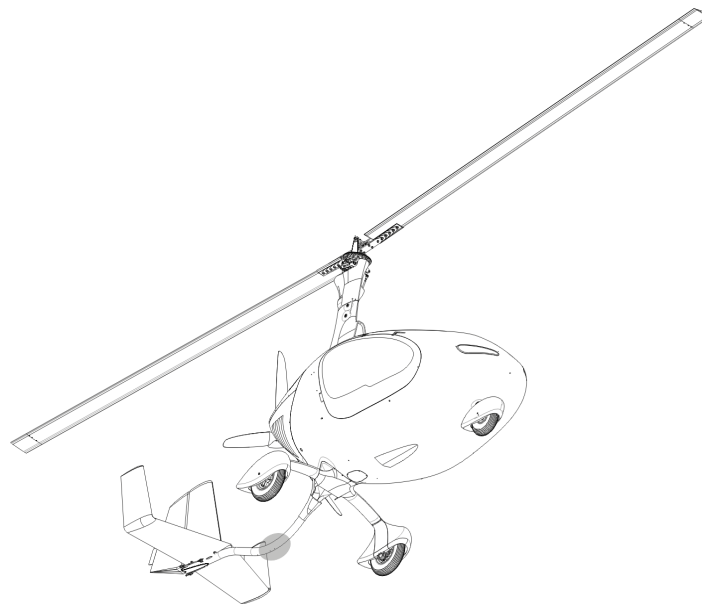

Fig. 1 - Installation position of keel tube protection pad

56-00-00 8-1 REPAIR: CRACKS IN ACRYLIC GLASS

OPR

GENERAL, REFERENCES AND REQUIREMENTS

Basic operational task, which can be performed by a licensed pilot or instructed personnel!

Repair only by a competent person.

Absolute cleanliness at any time during execution of the procedure must be ensured.

The following procedure is only approved for ductile (not brittle) canopies and windows without IR-/UV-protection of AutoGyro aircrafts.

Part must be in removed condition for executing the procedure.

SPECIAL TOOLS AND CONSUMABLE MATERIALS

PRECAUTIONS AND SAFETY MEASURES

WARNING Do not execute procedure in pilot's line of sight!

CAUTION Acrylic glass may not get in contact with thinners, alcohol, fuels etc. Window cleaner contain mostly alcohol. Vapours of thinners in workshops are also damaging.

NOTE The material strength in the area of repair is impaired.

NOTE Only AGOVIT® 1900 is approved.

NOTE Adhesive (AGOVIT® 1900 + KATALYSATOR 20) must be processed as quick as possible.

PROCEDURES

- 1 Clean acrylic glass with dishwashing liquid solution (2-3 drops per 0.2 l lukewarm tap water) and a clean sponge; let air dry or dry with damp chamois leather; for the repair material and adhesive should have a temperature of approx. 20°C.
- 2 Ensure a clean work environment with a temperature of approx. 20°C and good lighting conditions (day light is recommended).
- 3 Recommendation: If possible temper the acrylic glass at 80°C before and after the repair for avoiding stress cracks – material thickness divided by 3 to get the tempering duration in hours.
- 4 Stop drill the crack at the end using a 1.5 mm drill bit.
- 5 Fix crack with adhesive tape on the material bottom side, mill with low revolutions per minute (approx. 3000 min⁻¹) and low pressure a channel into material top side using a small multifunction rotary tool (Fig. 1).
- 6 Remove shavings carefully.
- 7 Position material so the crack is horizontal and mask the surrounding, intact acrylic glass with adhesive tape. Keep a distance to the edge of the channel of approx. 2 mm.
- 8 Stir AGOVIT® 1900 with 3-6 % hardener KATALYSATOR 20 in a PE-cup or glass bubble-free using a glass or metal stirring rod.
- 9 The adhesive must be applied in layers of approx. 2 mm thickness into the channel. The first layer must cover all areas of the channel and must protrude approx. 2 mm over the channel edge (Fig. 2). Any air bubbles or dirt particles can be pushed into the bead of adhesive to the top, as this will later be sanded away again. Next layers will be applied when the last layer is after approximately one hour hardened so far that it is not possible to push a nail or wire in.
- 10 After application of the last layer let adhesive seam harden for two hours at approx. 20°C.
- 11 Turn material upside-down.
- 12 Mill with low revolutions per minute (approx. 3000 min⁻¹) and low pressure a channel into material bottom side using a small multifunction rotary tool (Fig. 3).
- 13 Proceed as in steps 7-10 (Fig. 4).
- 14 Sand adhesive area as follows, begin with the convex outside of the acrylic glass:

- 15 Create dishwashing liquid solution (2-3 drops per 0.2 l lukewarm tap water). Sand with grit 320 wet sandpaper and dishwashing liquid solution to the surface of the tape.
- 16 When the adhesive tape is scratched, remove these and shade the area extensively with a felt pen (Edding blue or red).
- 17 Create new dishwashing liquid solution (2-3 drops per 0.2 l lukewarm tap water). Rinse to be sanded area and aids with dishwashing liquid solution. When carrying on wet sanding with grit 600 and dishwashing liquid solution can now be seen exactly where material is removed.
- 18 Create new dishwashing liquid solution (2-3 drops per 0.2 l lukewarm tap water). Rinse to be sanded area and aids with dishwashing liquid solution. Shade again (Edding blue or red) before reaching the surrounding surface and continue sanding with grit 900 wet sandpaper and dishwashing liquid solution until the shaded area and the adhesive bead are equally abraded.
- 19 Create new dishwashing liquid solution (2-3 drops per 0.2 l lukewarm tap water). Rinse to be sanded area and aids with dishwashing liquid solution. With MicroMesh abrasive cloth grit 3200, a cellular rubber sanding block and dishwashing liquid solution to carry on wet sanding until the surface is uniformly rough.
- 20 Create new dishwashing liquid solution (2-3 drops per 0.2 l lukewarm tap water). Rinse to be sanded area and aids with dishwashing liquid solution. Finish-sand with Micro Mesh abrasive cloth grit 8000, a cellular rubber sanding block and dishwashing liquid solution.
- 21 Create new dishwashing liquid solution (2-3 drops per 0.2 l lukewarm tap water). Clean acrylic glass with dishwashing liquid solution and a clean sponge; let air dry or dry with damp chamois leather.
- 22 Polish with a polishing pad and polishing agent XERAPOL[®]. Apply a pea-sized mass of polishing agent on the polishing pad. The speed must be selected not higher than approx. 800 min⁻¹. The polishing pad may not be used for too long on one place. Remove at regular intervals used polishing agent with an unused polishing cloth and repeat the process with new polishing agent. The XERAPOL[®] should result in a closed, silky shimmering layer during polishing. If this is not the case, the amount of polishing agent is too small.

ILLUSTRATIONS

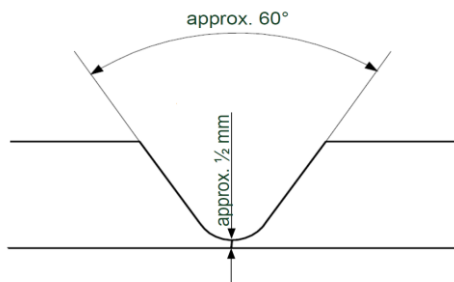

Fig. 1 – Milling of a channel on material top side

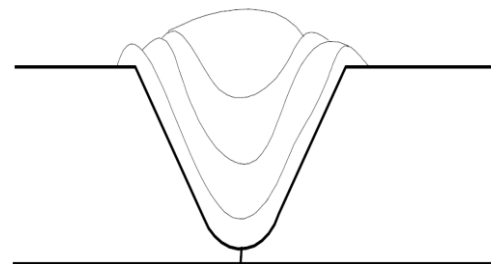

Fig. 2 – Filled channel on material top side

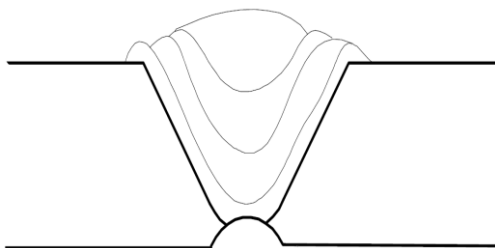

Fig 3. - Channel on material bottom side

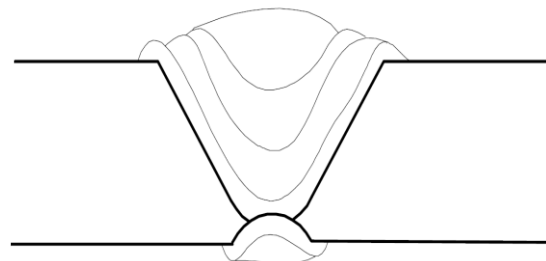

Fig 4. - Filled channels on material top and bottom side

61-10-00 4-1 REMOVAL-INSTALLATION: PROPELLER - HTC

LNE

GENERAL, REFERENCES AND REQUIREMENTS

Task may only be performed by an organization or individual trained and entitled to carry out 'Line Maintenance'!
Secure gyroplane against unauthorized or unintended operation!

SPECIAL TOOLS AND CONSUMABLE MATERIALS

AG-BAS-02 Loctite 243 blue (88-00-00-S-30483)

PRECAUTIONS AND SAFETY MEASURES

CAUTION: When removing or disassembling make sure to mark all parts so that each and every part of the component is re-assembled and installed in exactly the same location and orientation!

PROCEDURES

Removal

- 1 Before removing the spinner (optional equipment) check marking (filed notch) is available on spinner (1) and spinner base plate (8). If not, the installation position has to be marked accordingly.
- 2 Unscrew and remove bolts (9) with poly washers (10) and remove spinner.
- 3 Mark installation position of propeller hub, engine flange and spinner base plate (if installed) relative to each other.
- 4 Release torque on each bolt (4) by turning bolt half a revolution in counter-clockwise direction. Do not untighten or unscrew bolts (4)!
- 5 Unscrew and remove bolts (2) and washers (3).

Installation

- 6 Install propeller hub, bolts (2) with washers (3) in its original installation position.
- 7 Torque-tighten bolts (2) with 15 Nm in crosswise sequence.
- 8 Torque-tighten bolts (4) with 10 Nm in crosswise sequence.
- 9 Install spinner (1), spinner bolts (9) with poly washers (10). Make sure spinner is in correct installation position relative to spinner base plate. Check marking.
- 10 Secure spinner bolts (9) with AG-BAS-02 and torque-tighten with 3 Nm in crosswise sequence.

PARTS LIST

Fig.	Pos.	Description	PC PIT	Remark
1	1	spinner HTC3B, painted	L2 53-00-00-V-30587	
1	2	M8x110	NPI	
1	3	U8/24	NPI	
1	4	M6x40	NPI	ROTAX 914
1	4	M6x40	NPI	ROTAX 912
1	5	Propeller hub rear	L3 61-00-00-V-21191	ROTAX 912
1	5	Propeller hub front	L3 61-00-00-V-21190	ROTAX 914
1	6		61-00-00-V-32203	ROTAX 912
1	6		61-00-00-S-32464	ROTAX 914
1	7	Propeller hub rear	L3 61-00-00-V-21191	ROTAX 914
1	7	Propeller hub front	L3 61-00-00-V-21190	ROTAX 912
1	8	Spinner Plate	NPI	
1	9		71-00-00-V-31051	
1	10	U4, Poly	NPI	
1	11	torque bush spacer	NPI	
1	12	spacer propeller	NPI	

ILLUSTRATIONS

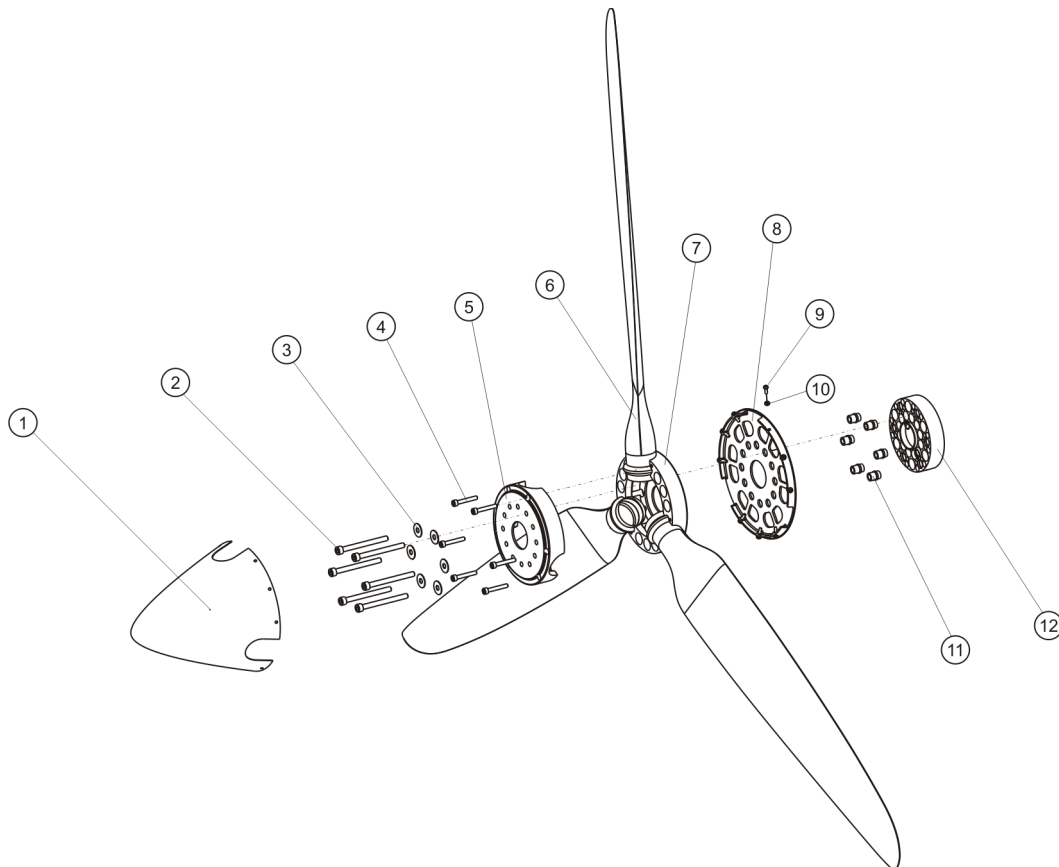

Fig. 1 - Propeller HTC

61-10-00 4-2 DISASSEMBLY-ASSEMBLY: PROPELLER - HTC

LNE

GENERAL, REFERENCES AND REQUIREMENTS

Task may only be performed by an organization or individual trained and entitled to carry out 'Line Maintenance'!

Propeller must be removed, see [61-10-00 4-1](#)

SPECIAL TOOLS AND CONSUMABLE MATERIALS

PRECAUTIONS AND SAFETY MEASURES

PROCEDURES

Disassembly

- 1 Mark inner and outer propeller hub to indicate relative installation position.
- 2 Place propeller assembly on a horizontal and clean surface and support propeller hub so that assembly does not lie on propeller blades.
- 3 Unscrew and remove bolts (4).
- 4 Remove outer propeller hub and remove individual blades.

Assembly

- 5 Place inner propeller hub on horizontal and clean surface and support propeller hub.
- 6 Insert individual blades in correct position.
- 7 Attach outer propeller hub, insert bolts (4) and hand-tighten.
- 8 Torque-tighten bolts (4) with 10 Nm in crosswise sequence.

PARTS LIST

Fig.	Pos.	Description	PC PIT	Remark
1	1	spinner HTC3B, painted	L2 53-00-00-C-30587	
1	2	M8x110	NPI	
1	3	U8/24	NPI	
1	4	M6x40	NPI	ROTAX 912
1	4	M6x40	NPI	ROTAX 914
1	5	Propeller hub front	L3 61-00-00-M-21190	ROTAX 914
1	5	Propeller hub rear	L3 61-00-00-M-21191	ROTAX 912
1	6		61-00-00-V-32203	ROTAX 912
1	6		61-00-00-S-32464	ROTAX 914
1	7	Propeller hub rear	L3 61-00-00-V-21191	ROTAX 914
1	7	Propeller hub front	L3 61-00-00-V-21190	ROTAX 912
1	8	Spinner Plate	NPI	
1	9		71-00-00-V-31051	
1	10	U4, Poly	NPI	
1	11	torque bush spacer	NPI	
1	12	spacer propeller	NPI	

ILLUSTRATIONS

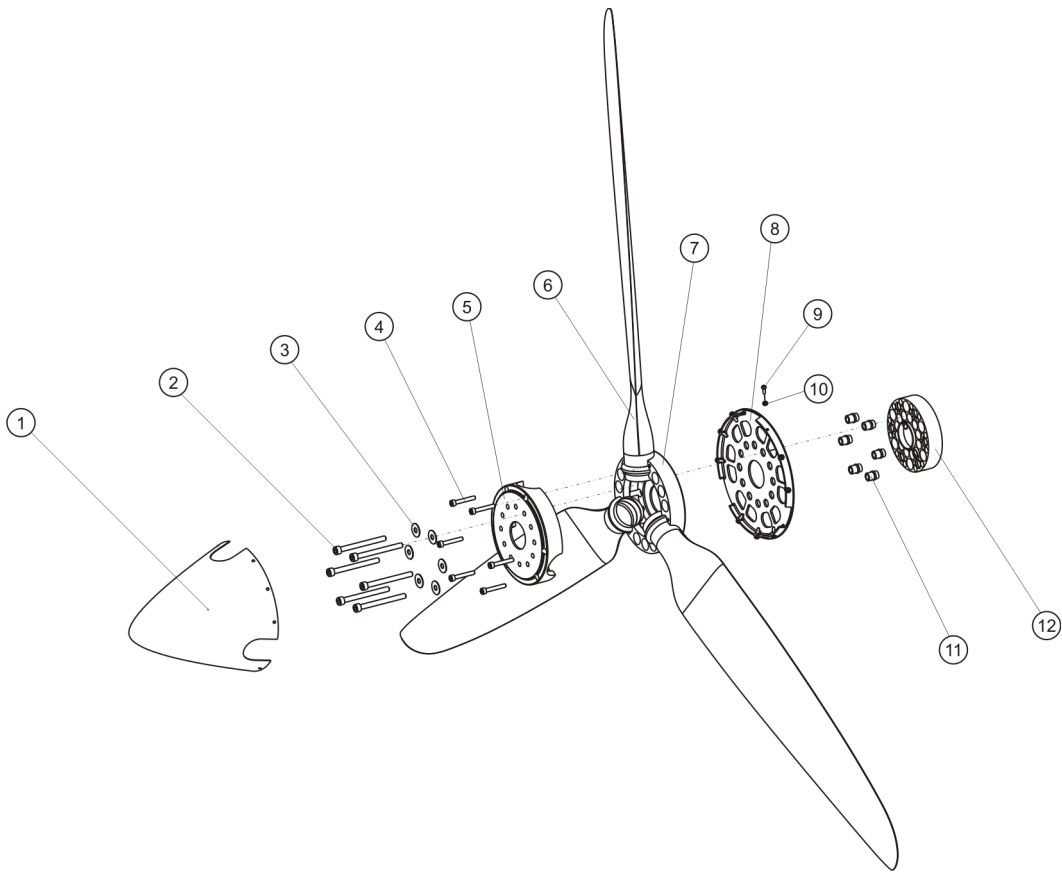

Fig. 1 - Propeller HTC

61-10-00 5-1 ADJUSTMENT: PROPELLER PITCH - HTC

LNE

GENERAL, REFERENCES AND REQUIREMENTS

Task may only be performed by an organization or individual trained and entitled to carry out 'Line Maintenance'!
Spinner (if installed) must be removed, see [61-10-00 4-1](#)

SPECIAL TOOLS AND CONSUMABLE MATERIALS

PRECAUTIONS AND SAFETY MEASURES

PROCEDURES

- 1 Untighten bolts (Fig. 1, 4) so that bolt heads does not contact outer propeller hub.
- 2 Unscrew bolts (Fig. 1, 2) about 2 revolutions.
- 3 Position propeller pitch adjustment tool with the inner side on outer propeller hub and profiled section on the propeller blade.
- 4 Carefully adjust blade pitch by tapping with a 200 g rubber hammer in the area of the blade's nose section so that blade pitch increases or decreases. Never use hammer on trailing edge as the blade may be damaged that way.
- 5 In order to read the correct setting it is advisable to let the blade's trailing edge rest in (touch) the tool while allowing a small light gap between blade's back and the tool's profiled section.
- 6 Repeat work steps 3 to 5 for the remaining blades.
- 7 Hand-tighten bolts (Fig. 1, 2) and (Fig. 1, 4) and check blade pitch setting for all blades. If necessary, untighten bolts and re-do from step 1.
- 8 Torque-tighten bolts (Fig. 1, 2) with 15 Nm in crosswise sequence.
- 9 Torque-tighten bolts (Fig. 1, 4) with 10 Nm in crosswise sequence.
- 10 Perform torque-check after first flight or ground run.

PARTS LIST

Fig.	Pos.	Description	PC PIT	Remark
1	1	spinner HTC3B, painted	L2 53-00-00-C-30587	
1	2	M8x110	NPI	
1	3	U8/24	NPI	
1	4	M6x40	NPI	ROTAX 914
1	4	M6x40	NPI	ROTAX 912
1	5	Propeller hub front	L3 61-00-00-M-21190	ROTAX 914
1	5	Propeller hub rear	L3 61-00-00-M-21191	ROTAX 912
1	6		61-00-00-V-32203	ROTAX 912
1	6		61-00-00-S-32464	ROTAX 914
1	7	Propeller hub rear	L3 61-00-00-V-21191	ROTAX 914
1	7	Propeller hub front	L3 61-00-00-V-21190	ROTAX 912
1	8	Spinner Plate	NPI	
1	9		71-00-00-V-31051	
1	10	U4, Poly	NPI	
1	11	torque bush spacer	NPI	
1	12	spacer propeller	NPI	

ILLUSTRATIONS

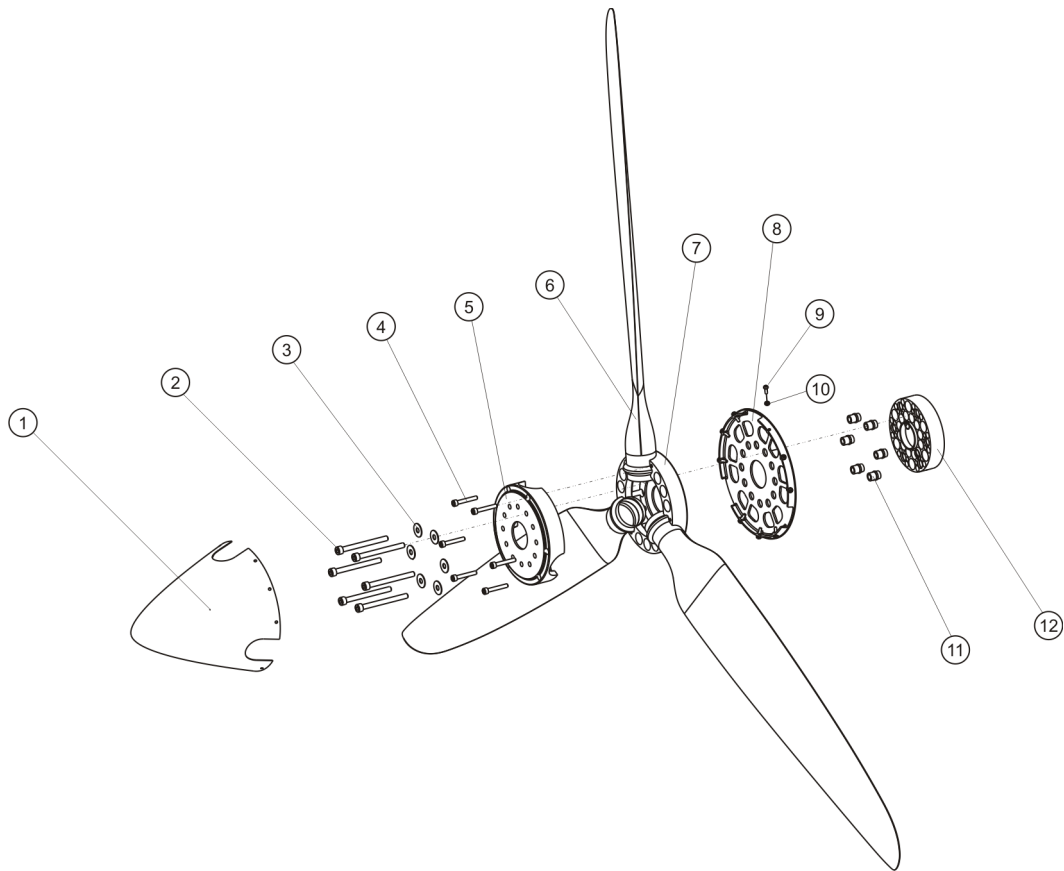

Fig. 1 - Propeller HTC

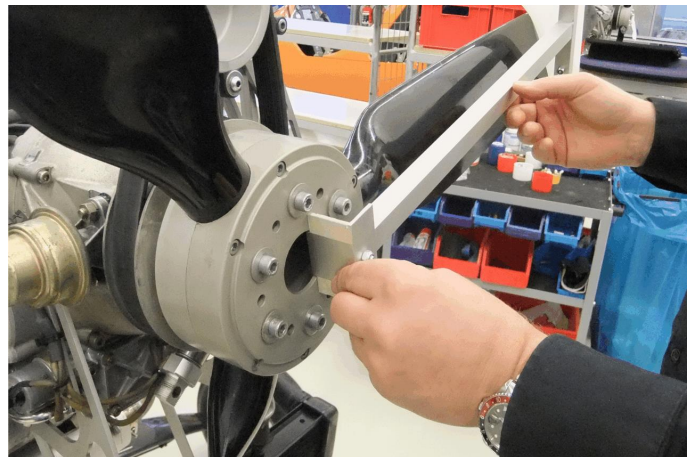

Fig. 2 - Propeller pitch adjustment and tool

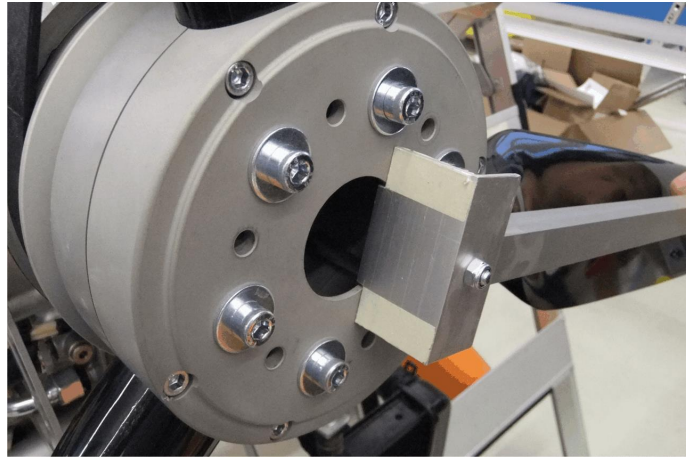

Fig. 3 - Detail hub

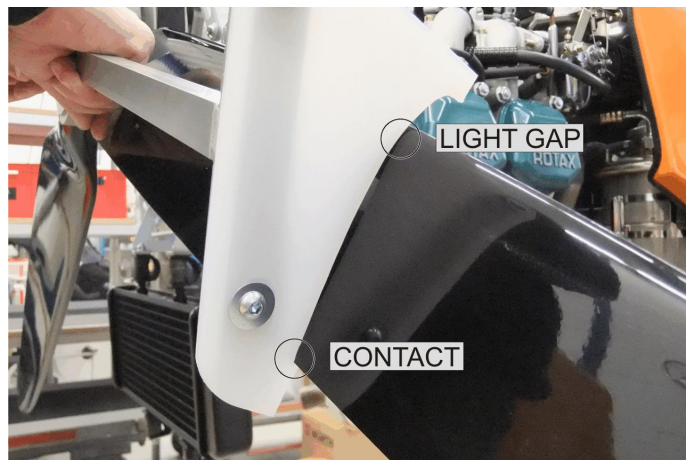

Fig. 4 - Detail blade

61-10-00 8-2 RETROFIT: END POSITION DETECTION IVO PROPELLER OPR

GENERAL, REFERENCES AND REQUIREMENTS

Basic operational task, which can be performed by a licensed pilot or instructed personnel!

Secure gyroplane against unauthorized or unintended operation!

SPECIAL TOOLS AND CONSUMABLE MATERIALS

PRECAUTIONS AND SAFETY MEASURES

CAUTION: Failure to comply with this instruction will cause the loss of warranty referred and/or related components.

PROCEDURES

- 1 Contents of the kit (Fig. 1):
 - 1) **IVO-Control** with pin assignment
 - 2) **2 x Shrinking Hose** to isolate unused connectors
 - 3) **2 x LED-Mount** for 5mm Status LEDs
 - 4) **3 x Cable Ties** to fixate cables and installation
 - 5) **Blind Plug** to cover installation bore of removed thermo switch
 - 6) **Mask** for rocker switch and LEDs
 - 7) **Rocker switch**
 - 8) **4 x screws and 4 x nuts** for installation of the mask

- 2 Pin assignment of wiring harness - top to bottom (Fig. 2):
 - red
 - orange
 - green
 - black
 - orange/white
 - green/white

- 3 Equip mask as shown in Fig. 3 und install with screws and nuts in cockpit.

- 4 Fixate LED with mounting ring and nut from behind (see Fig. 4)

CAUTION: Do not push (or pull) at the LED cables. Use proper tools at LED socket.

- 5 Insert LEDs in mount (use pliers, if needed)

- 6 LED with cable color orange goes in upper position, green in bottom position.

- 7 Connect control board with rocker switch:
 - Switch/position '1a' (top): green/white
 - Switch/position '1' (middle): black
 - Switch/position '1b' (bottom): orange/white

CAUTION: Do not mismatch electrical connectors as control board can be destroyed!

- 8 Connect cockpit controls to control board (see Fig. 5, note condensers facing up):
 - white/orange (IVO)
 - white/violett (IVO)
 - black (GND)
 - violett/orange (12V+)

- 9 Check switching and indication logic (Master switch 'ON!'):

Press rocker switch 'fine' position
upper LED must blink, propeller must adjust to fine (take-off)

Press rocker switch 'coarse' pos.
lower LED must blink, propeller must adjust to coarse (cruise)

- 10 Fixate cables and control board with cable ties.

- 11 Perform functional check.

PARTS LIST

Fig.	Pos.	Description	PC PIT	Remark
		IVO installation kit	L1 24-00-00-V-34771	
		IVO-end position indicator	L1 24-00-00-V-34759	

ILLUSTRATIONS

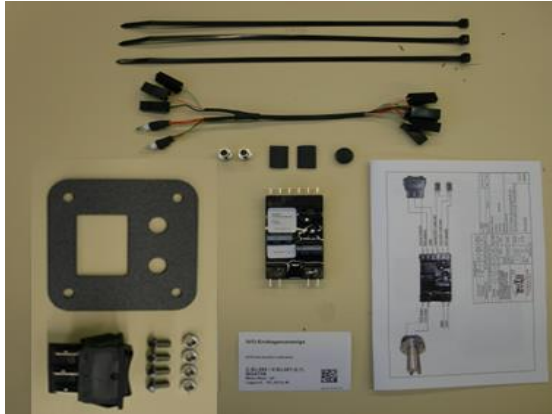

Fig. 1 - Contents of the Kit

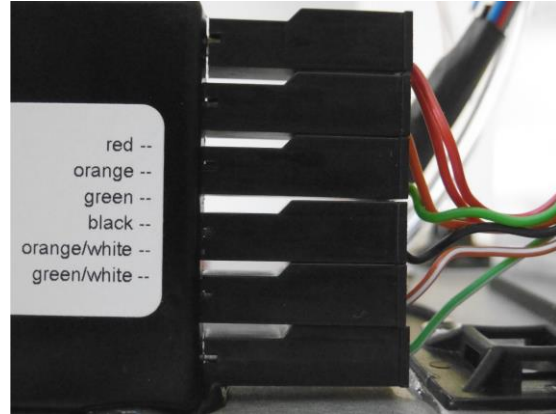

Fig. 2 - Pin assignment of wiring harness



Fig. 3 - Rocker Switch and LEDs



Fig. 4 - Rocker Switch and LEDs - seen from behind

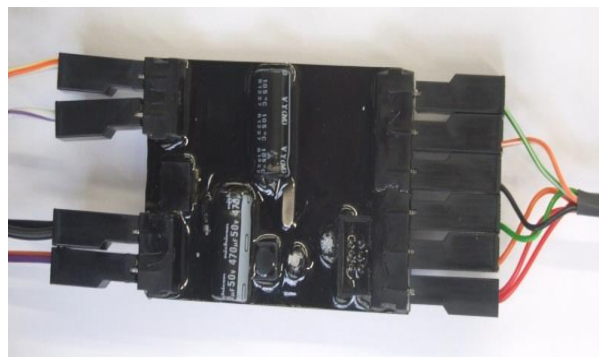

Fig. 5 - Control Board

61-20-00 1-1 TROUBLE-SHOOTING: IVO-VARIABLE PITCH PROPELLER **LNE**

GENERAL, REFERENCES AND REQUIREMENTS

SPECIAL TOOLS AND CONSUMABLE MATERIALS

PRECAUTIONS AND SAFETY MEASURES

WARNING: Electrical shorting of the battery will produce high current with the risk of personal injury and damage to equipment!

NOTE If it is necessary to connect the collector rings directly to electrical power within the fault tree analysis pull off contacts from carbon brushes.

PROCEDURES

- 1 Inspect wear of carbon brushes, replace if necessary
- 2 Insulating disk may not protrude between collector rings, if necessary remove using a bevelled-edge chisel
- 3 Polish collector rings with non-woven web, so that collector rings are blank-surfaced
- 4 Perform ground test run immediately after the foregoing step
- 5 Do not clean collector rings from carbon abrasion debris (protection against oxidisation)
- 6 Execute fault tree analysis (Fig. 1)

ILLUSTRATIONS

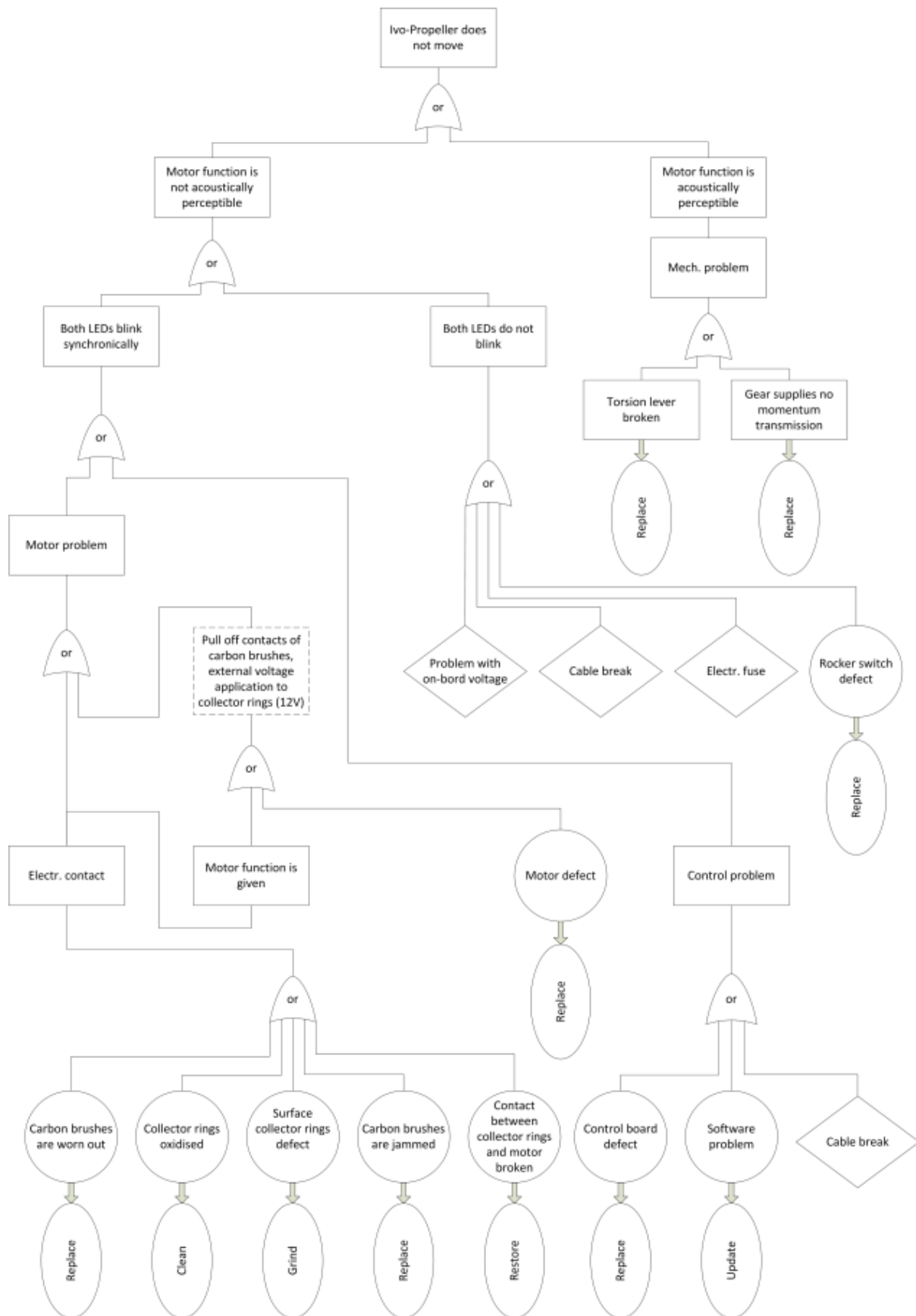

Fig. 1 – Fault Tree IVO Variable Pitch Propeller

62-11-00 4-1 REMOVAL: ROTOR - TEETERING PARTS

OPR

GENERAL, REFERENCES AND REQUIREMENTS

Basic operational task, which can be performed by a licensed pilot or instructed personnel!

SPECIAL TOOLS AND CONSUMABLE MATERIALS

AG-BAS-01 Loctite 221 red (88-00-00-S-30487)

LR **IMPORTANT NOTE:** Procedure involves parts with limited reusability. Check parts list below before starting job!

PRECAUTIONS AND SAFETY MEASURES

WARNING: *Wear eye protection and mind FOD when removing attachment hardware!*

WARNING: *Object is heavy! Inadequate handling could cause injury. Use proper lifting techniques or assistance!*

WARNING: *Never place the rotor system on a dirty or grainy surface and avoid bending moments at the blade attachments!*

WARNING: *When handled incorrectly the rotor system can be damaged irreparably. If undetected this may have catastrophic consequences!*

CAUTION: *When removing or disassembling make sure to mark all parts so that each and every part of the component is re-assembled and installed in exactly the same location and orientation!*

IMPORTANT NOTE: *Some rotor blades have loose washers in them which are required as balance weights. Do not remove or restrain if present!*

PROCEDURES

- 1 Secure the gyroplane on level ground by engaging the parking brake, adjust the rotor system lengthwise and pump up the rotor brake to its maximum.
- 2 Remove and discard split pin and unscrew the castellated nut (4). The rotor system has to be tilted onto the black rotor teeter stop.
- 3 The teeter bolt (1) has to be extracted by using only the hand, not a hammer. If needed tilt the rotor blades carefully onto the teeter stop, in order to prevent the bolt from jamming. Make sure that the rotor stays level in the teeter axis, if not the teeter bolt will damage the Teflon coated bushes, while being pushed out.
- 4 A supervised second person has to hold the rotor system in flying direction.
- 5 Lift the rotor system carefully out of the teeter tower and be aware of the position of the shim washers (2). Their thicknesses may differ and it is essential that they are reinstalled on the correct side! They are marked with dots to identify the correct side.
- 6 Remove the rotor system to one side by letting it rest on your shoulder and take care not to collide with stabilizer or propeller.
- 7 The shim washers and the teeter block in the hub are marked on each side with one or two engraved dots. Directly after the disassembly the shim washers need to be fixed on their respective side with cable ties.
- 8 If possible, handle with two persons while holding approximately in the middle of each blade. When supporting the system use two stands each positioned in about 2 metres distance from the hub.
- 9 The rotor system must not be placed on a dirty or grainy surface, as the blades can scratch and damage easily. The best way is to place the rotor blades centrally onto two stands, supporting the rotor at approximately 2 m distance from the hub.

PARTS LIST

Fig.	Pos.	Description	PC PIT	Remark
1	1	Teeterbolt	L0 27-30-00-S-30256	
1	2	Chimm washer 3,5	L0 62-00-00-S-31706	
1	3	U13	L0 27-30-00-S-30256	
1	4	M12 castle nut	L0 27-30-00-S-30256	
1	5	Split pin 3.2x40	L0 27-30-00-S-30256	
1	6	Rotor head II compl.	L2 27-30-00-V-33433	

ILLUSTRATIONS

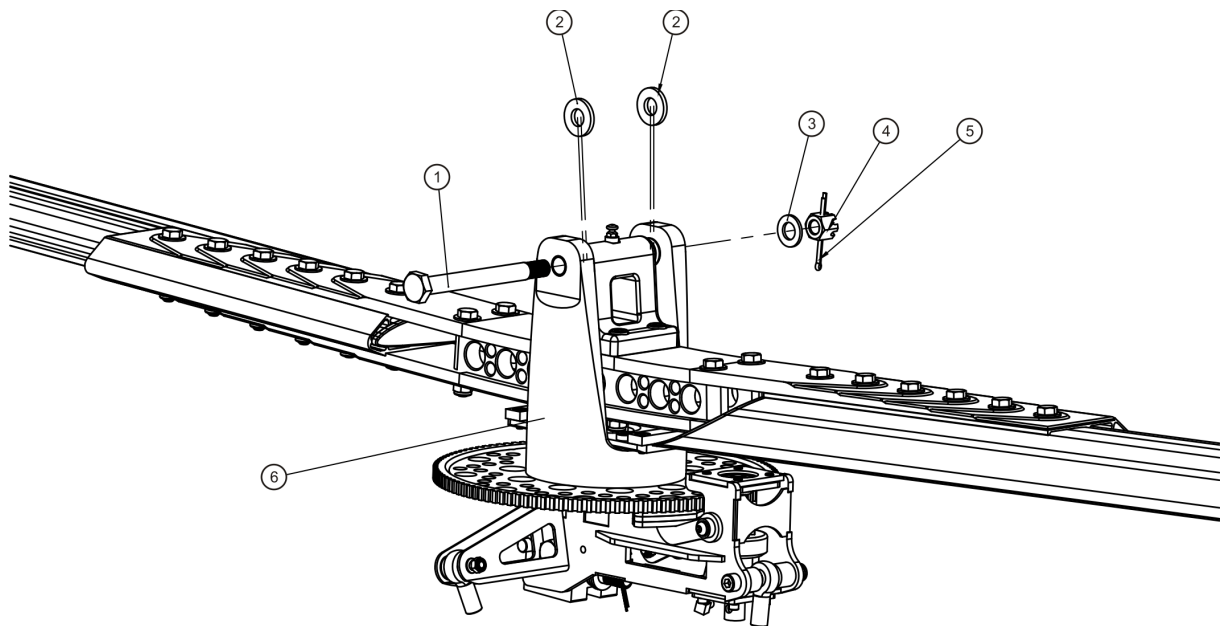

Fig. 1 - Removal rotor - teetering parts (Effectivity: RS II)

62-11-00 4-2 DISASSEMBLY: ROTOR - TEETERING PARTS

OPR

GENERAL, REFERENCES AND REQUIREMENTS

Basic operational task, which can be performed by a licensed pilot or instructed personnel!

Rotor system must be removed, see [62-11-00 4-1](#)

SPECIAL TOOLS AND CONSUMABLE MATERIALS

LR **IMPORTANT NOTE:** Procedure involves parts with limited reusability. Check parts list below before starting job!

PRECAUTIONS AND SAFETY MEASURES

WARNING: *When handled incorrectly the rotor system can be damaged irreparably. If undetected this may have catastrophic consequences!*

CAUTION: *The rotor hub must never be disassembled!*

CAUTION: *When removing or disassembling make sure to mark all parts so that each and every part of the component is re-assembled and installed in exactly the same location and orientation!*

PROCEDURES

- 1 To disassemble the rotor system, place it upside down onto a clean surface or stands to support the rotor at approximately 2 m from the hub.
- 2 Unscrew and discard self-locking nuts (9) on the first blade by counter-holding the corresponding bolt head to prevent it from turning.
- 3 Push out all shoulder bolts (1 - 5) without any force, but use no more than a gentle tapping if necessary. Tilt the rotor blade up and down to support easy removal of the bolt
- 4 Carefully pull the rotor blade out of the hub (7) in radial direction and take off the clamping profile (10).
- 5 Repeat step 2 to 4 on second rotor blade.

IMPORTANT NOTE: *Do not disassemble the rotor hub!*

- 6 Place rotor blades, clamping profile and rotor hub in a suitable way to prevent bending or surface damage.

IMPORTANT NOTE: *Do not lift or support the rotor system at its blade tips as the bending moment due to the weight of the hub assembly may overstress the blade roots. If possible, handle with two persons while holding approximately in the middle of each blade. When supporting the system use two stands each positioned in about 2 metres distance from the hub.*

PARTS LIST

Fig.	Pos.	Description	PC PIT	Remark
1	1	shoulder bolt M8 37/12	L0 62-00-00-S-33324	
1	1-5	M8x60 Rotor blade bolt 8.8 DIN 610	L0 62-00-00-V-20661	
1	2	shoulder bolt M8 40/12	L0 62-00-00-S-33324	
1	3	shoulder bolt M8 43/12	L0 62-00-00-S-33324	
1	4	shoulder bolt M8 46/12	L0 62-00-00-S-33324	
1	5	M8x60 Rotor blade bolt 8.8 DIN 610	L0 62-00-00-V-20661	
1	6	U9/20	L0 62-00-00-S-33324	
1	7	Rotorhub II	L1 01-00-00-V-31793	
1	8	U8	L0 62-00-00-S-33324	
1	9	M8 Si	L0 62-00-00-S-33324	
1	10	Clamping profile blade	L1 01-00-00-V-31793	

ILLUSTRATIONS

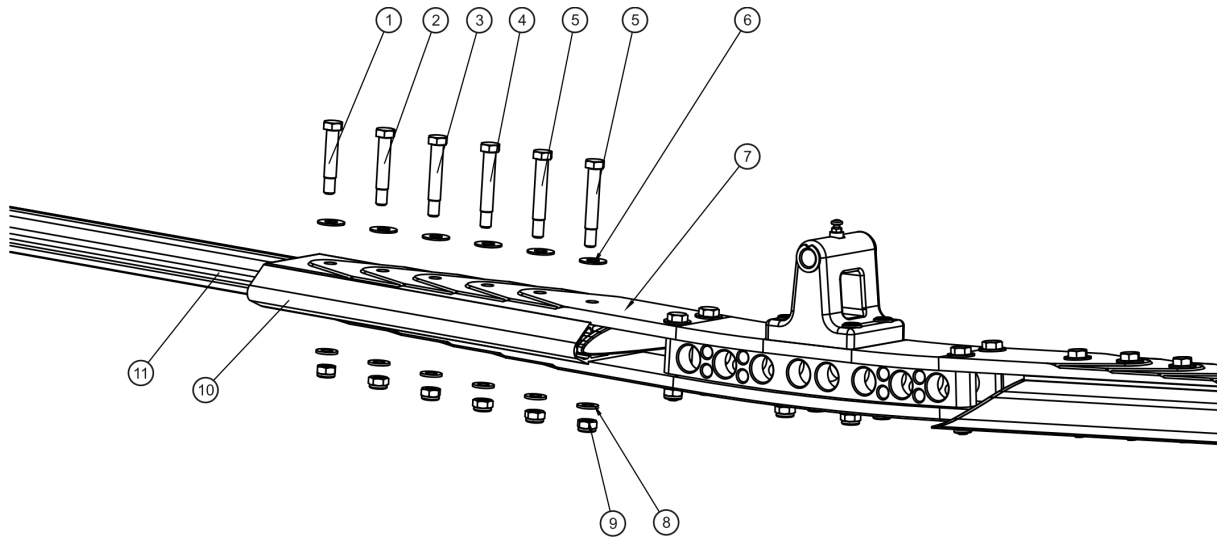

Fig. 1 - Disassembly rotor - teetering parts (Effectivity: RS II)

62-11-00 4-3 ASSEMBLY: ROTOR - TEETERING PARTS

OPR

GENERAL, REFERENCES AND REQUIREMENTS

Basic operational task, which can be performed by a licensed pilot or instructed personnell!

SPECIAL TOOLS AND CONSUMABLE MATERIALS

LR **IMPORTANT NOTE:** Procedure involves parts with limited reusability. Check parts list below before starting job!

PRECAUTIONS AND SAFETY MEASURES

WARNING: When handled incorrectly the rotor system can be damaged irreparably. If undetected this may have catastrophic consequences!

CAUTION: When removing or disassembling make sure to mark all parts so that each and every part of the component is re-assembled and installed in exactly the same location and orientation!

PROCEDURES

- 1 The rotor blades (11), clamping profile (10) and rotor hub (7) are each labelled with an engraved serial number.
- 2 Insert the first rotor blade carefully into the clamping profile. Make sure that all serial numbers match.

IMPORTANT NOTE: Grease shaft with AG-LUB-03, but do not allow AG-LUB-03 to come into contact with threads at any time!
- 3 Fit the rotor hub side with the according serial number to clamping profile (7) and blade (11). Insert 6 x shoulder bolts (1-5) and corresponding washers (6) without using force so that the bolt end is on top when the rotor system is installed. For re-identification and correct installation position the shaft length is provided in the figure above. Example: 40/12 means shaft length 40mm.
- 4 Position the washers (8) and the self-locking nuts (9) and hand-tighten.
- 5 Torque-tighten nuts (9) with 15 Nm from the inside to the outside. When doing so, counter-hold bolts (5) to prevent any damage to the hub and blade holes.
- 6 Repeat work steps 2 to 5 for the second rotor blade.
- 7 Check rotor system alignment according to [62-11-00 5-1](#) and adjust, if necessary.

PARTS LIST

Fig.	Pos.	Description	PC PIT	Remark
1	1	shoulder bolt M8 37/12	L0 62-00-00-S-33324	
1	1-5	M8x60 Rotor blade bolt 8.8 DIN 610	L0 62-00-00-V-20661	
1	2	shoulder bolt M8 40/12	L0 62-00-00-S-33324	
1	3	shoulder bolt M8 43/12	L0 62-00-00-S-33324	
1	4	shoulder bolt M8 46/12	L0 62-00-00-S-33324	
1	5	M8x60 Rotor blade bolt 8.8 DIN 610	L0 62-00-00-V-20661	
1	6	U9/20	L0 62-00-00-S-33324	
1	7	Rotorhub II	L1 01-00-00-V-31793	
1	8	U8	L0 62-00-00-S-33324	
1	9	M8 Si	L0 62-00-00-S-33324	
1	10	Clamping profile blade	L1 01-00-00-V-31793	

ILLUSTRATIONS

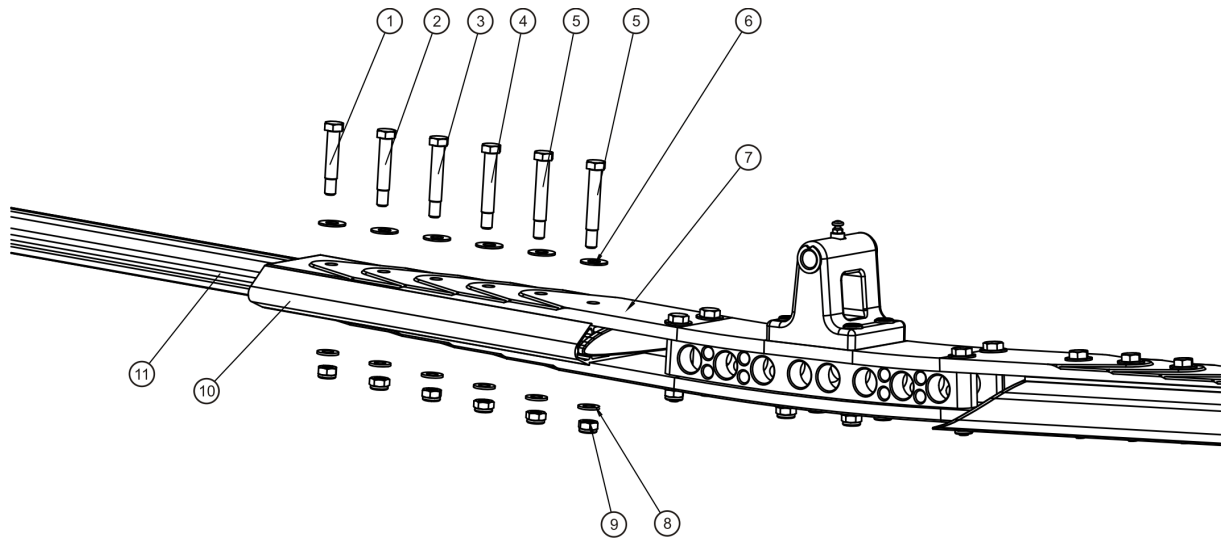

Fig. 1 - Assembly rotor - teetering parts (Effectivity: RS II)

62-11-00 4-4 INSTALLATION: ROTOR - TEETERING PARTS

OPR

GENERAL, REFERENCES AND REQUIREMENTS

Basic operational task, which can be performed by a licensed pilot or instructed personnel!

Secure gyroplane against unauthorized or unintended operation!

SPECIAL TOOLS AND CONSUMABLE MATERIALS

AG-GRS-01 Lagermeister WHS 2002 Grease (88-00-00-S-30477)

LR **IMPORTANT NOTE:** Procedure involves parts with limited reusability. Check parts list below before starting job!

PRECAUTIONS AND SAFETY MEASURES

WARNING: Object is heavy! Inadequate handling could cause injury. Use proper lifting techniques or assistance!

WARNING: When handled incorrectly the rotor system can be damaged irreparably. If undetected this may have catastrophic consequences!

PROCEDURES

- 1 Secure the gyroplane on level ground by engaging parking brake, adjust the rotor head or teeter tower corresponding to fore-aft and pressurize the rotor brake up to maximum.
- 2 Check correct matching of parts: The rotor hub and the teeter tower are marked with two dots according to the orientation for installation.
- 3 Lift the rotor blade with a second briefed person (one person standing aft, one person standing directly in front of the hub).
- 4 Approach with the rotor system from the side to the gyroplane and make sure not to collide with propeller or stabilizer. Insert the rotor system into the hub from above while standing on a ladder or the rear seat.
- 5 The second person can let go, as soon as it is resting centrally in the teeter tower on the teeter stops.
- 6 Apply a thin layer of AG-GRS-01 on teeter bolt.
- 7 Insert teeter bolt by hand in the same orientation as it was before (bolt head should be at that side of the teeter block which is marked with one dot) while matching the shim washers with the corresponding installation positions. Insert teeter bolt by hand in the same orientation as it was before (bolt head should be at that side of the teeter block which is marked with one dot) while matching the shim washers with the corresponding installation positions.
- 8 Check direction of assembly and shim washers: rotor hub, teeter tower and shim washers are marked on each side either with one or two engraved dots.
- 9 If the teeter bolt cannot be inserted, tilt the rotor blade along the teeter axis with the free hand.
- 10 Install washer and castellated nut. Hand-tighten only and secure with a new split pin. Use split pins only once. Make sure that the teeter bolt can be turned easily by hand.
- 11 Grease nipple in teeter block.

PARTS LIST

Fig.	Pos.	Description	PC PIT	Remark
1	1	Teeterbolt	L0 27-30-00-S-30256	
1	2	Chimm washer 3,5	L0 62-00-00-S-31706	
1	3	U13	L0 27-30-00-S-30256	
1	4	M12 castle nut	L0 27-30-00-S-30256	
1	5	Split pin 3.2x40	L0 27-30-00-S-30256	
1	6	Rotor head II compl.	L2 27-30-00-V-33433	

ILLUSTRATIONS

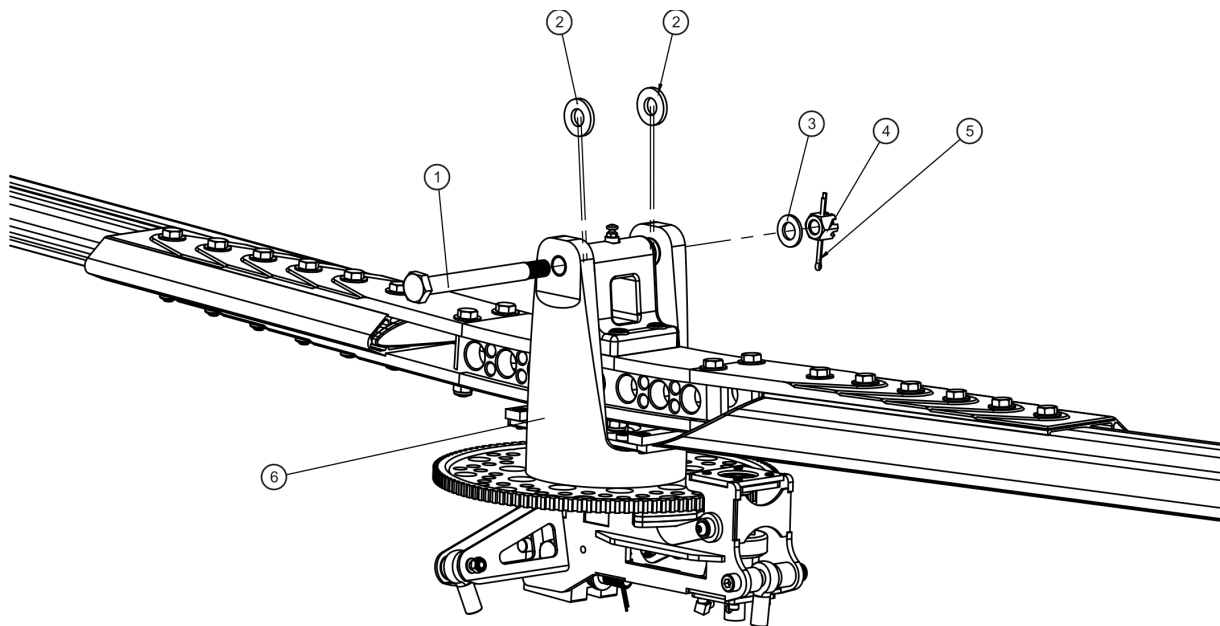

Fig. 1 - Installation rotor - teetering parts (Effectivity: RS II)

62-11-00 5-1 CHECK-ADJUSTMENT: ROTOR SYSTEM ALIGNMENT

LNE

GENERAL, REFERENCES AND REQUIREMENTS

Task may only be performed by an organization or individual trained and entitled to carry out 'Line Maintenance'!

Rotor system must be removed, see [62-11-00 4-1](#)

Rotor system must be placed on suitable supports to avoid scratching of the blades or bending moments at the blade attachment

SPECIAL TOOLS AND CONSUMABLE MATERIALS

None

PRECAUTIONS AND SAFETY MEASURES

WARNING: Object is heavy! Inadequate handling could cause injury. Use proper lifting techniques or assistance!

WARNING: Do not lift or support the rotor system at its blade tips as the bending moment due to the weight of the hub assembly may overstress the blade roots!

WARNING: Never place the rotor system on a dirty or grainy surface and avoid bending moments at the blade attachments!

WARNING: When handled incorrectly the rotor system can be damaged irreparably. If undetected this may have catastrophic consequences!

PROCEDURES

- 1 Place rotor system on suitable stands on level ground. Make sure stand surface is level and stand is oriented exactly 90 degrees to rotor blade (see Fig. 1).
- 2 String measuring cord between both outer blade tips. Position at rivet as depicted in Fig. 2 'Positioning of measuring cord'.
- 3 Adjust distance of stand carefully so that measuring cord is strung slightly above the central grease nipple. Verify centre position of grease nipple (Fig. 3).
- 4 In case the measuring cord deviates by more than 2 mm from centre position (i.e. grease nipple inner bore), adjust rotor system linearity. To do so perform the following work steps:
- 5 Untighten the self-locking nuts of the blade attachment bolts, except for the most inner bolt(s). Counter-hold bolt head to prevent it from turning.
- 6 Adjust linearity/alignment of rotor system and tighten nuts. Perform alignment check. If necessary, repeat procedure from step 5 on.
- 7 Torque-tighten nuts with 15 Nm from the inside to the outside. When doing so, counter-hold bolts to prevent any damage to the hub and blade holes.
- 8 Perform final linearity/alignment check. If necessary, repeat procedure from step 5 on.
- 9 Perform final linearity/alignment check. If necessary, repeat procedure from step 5 on.

ILLUSTRATIONS

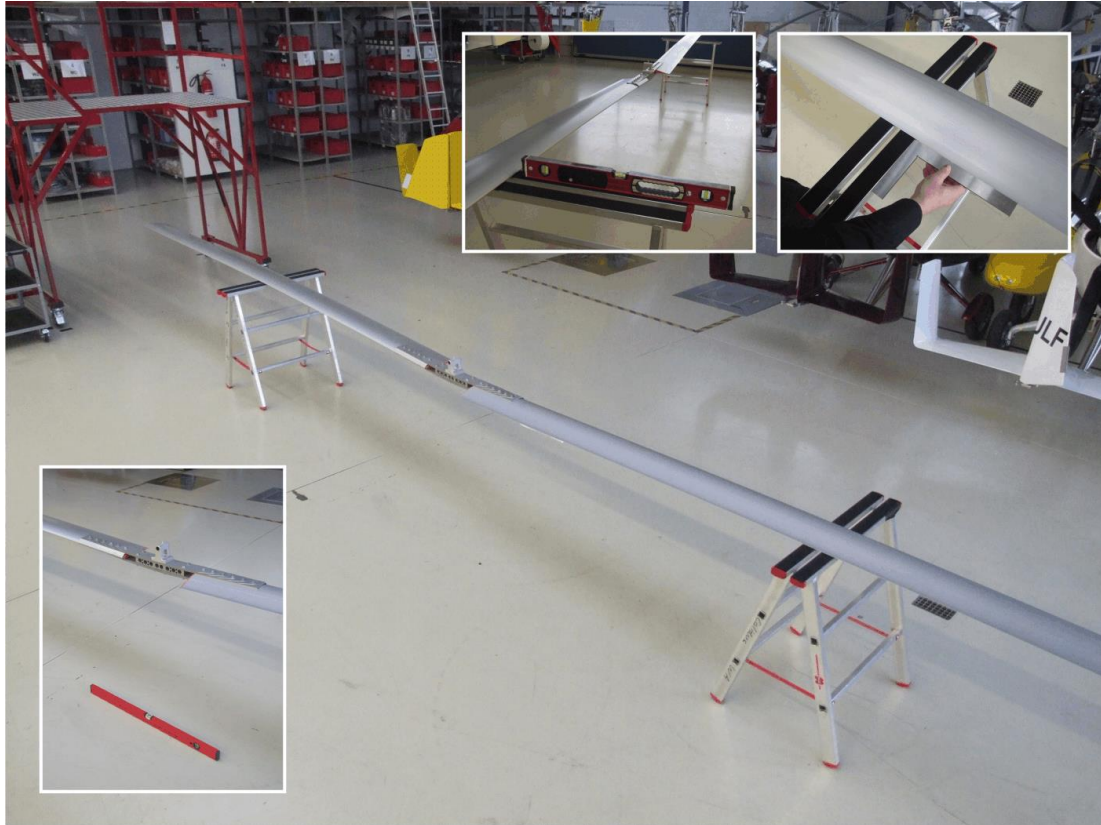

Fig. 1 - Rotor system placed on stands



Fig. 2 - Positioning of measuring cord

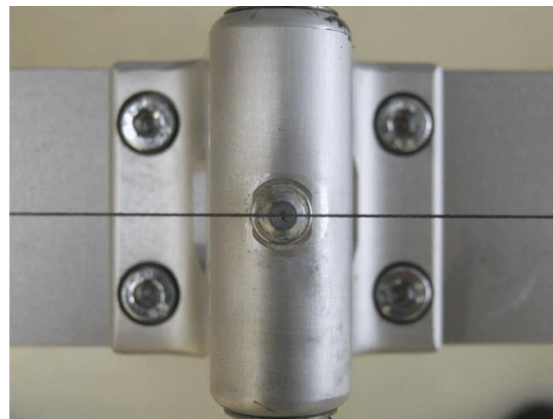

Fig. 3 - Reference point at grease nipple

62-11-00 6-1 INSPECTION: ROTOR - TEETERING PARTS

LNE

GENERAL, REFERENCES AND REQUIREMENTS

Task may only be performed by an organization or individual trained and entitled to carry out 'Line Maintenance'!

Rotor system must be removed, see [62-11-00 4-1](#)

SPECIAL TOOLS AND CONSUMABLE MATERIALS

AG-GRS-01 Lagermeister WHS 2002 Grease (88-00-00-S-30477)

PRECAUTIONS AND SAFETY MEASURES

WARNING: Never place the rotor system on a dirty or grainy surface and avoid bending moments at the blade attachments!

WARNING: When handled incorrectly the rotor system can be damaged irreparably. If undetected this may have catastrophic consequences!

PROCEDURES

- 1 Check inner and outer blade caps for tight fit and general condition. Visible insets or score marks may indicate contact with obstacles with possible damage to the rotor system.
- 2 Perform visual inspection of clamping profile.
- 3 Perform visual inspection of rotor hub.
- 4 Perform visual inspection of grease nipple and check tight fit
- 5 Check rotor system alignment [62-11-00 5-1](#), i.e. work steps 1 to 3 for trend monitoring purposes.
- 6 Inspect teeter bolt. In order to do so, clean with lint-free cloth and inspect for wear marks and corrosion. If corrosion or wear marks are evident (fingernail test), the teeter bolt must be discarded and replaced.
- 7 Apply a thin layer of AG-GRS-01 on teeter bolt using a lint-free cloth.
- 8 Inspect bushings in teeter block and teeter tower for correct seating (see Fig. 1 for positions of slits) and secure installation (must not be possible to turn by hand). Otherwise, bushings must be replaced, see [62-11-00 8-1](#).
- 9 Insert teeter bolt in teeter block and inspect for play. If any bearing play is evident, try with new teeter bolt. If play is still evident, replace teeter block bushing, see [62-11-00 8-1](#).
- 10 Insert teeter bolt in teeter tower and inspect for play. If any bearing play is evident, try with new teeter bolt. If play is still evident, replace teeter tower bushings, see [62-11-00 8-1](#).

PARTS LIST

Fig.	Pos.	Description	PC PIT	Remark
1	1	Bushing TEF-MET 13/15/21x15	L0 27-30-00-V-20677	
1	2	Bushing TEF-MET 13/15/21x15	L2 27-30-00-V-20677	
		Teeterbolt kit	L0 27-30-00-S-30256	

ILLUSTRATIONS

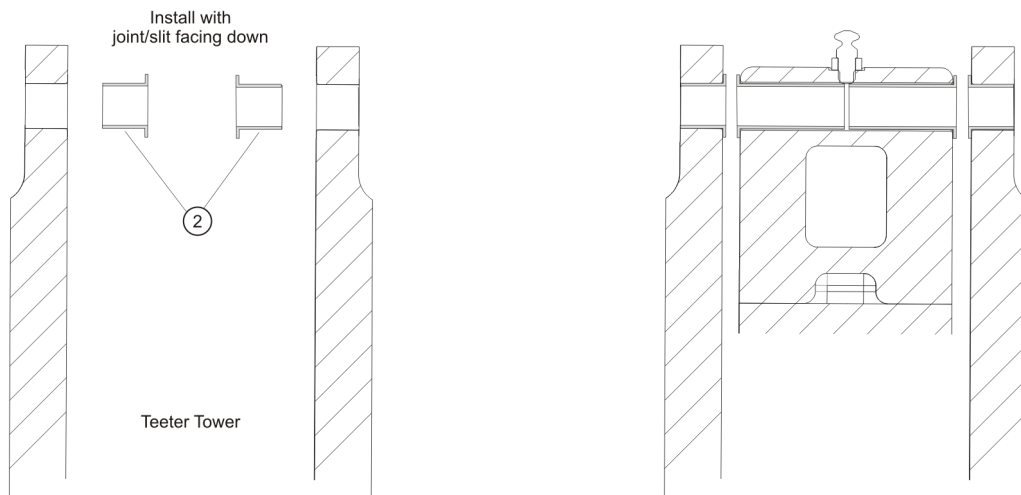
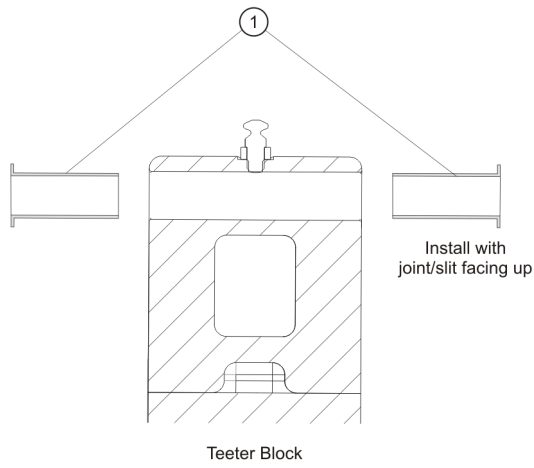
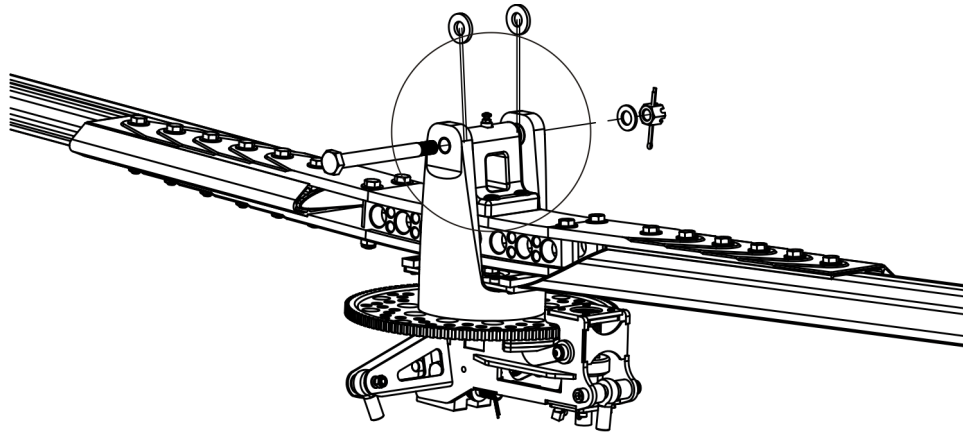

Fig. 1 - Teeter bushings, block and tower - cross section view

62-11-00 6-2 INSPECTION: ROTOR BLADES

OPR

GENERAL, REFERENCES AND REQUIREMENTS

Basic operational task, which can be performed by a licensed pilot or instructed personnell!

Rotor system must be disassembled, see [62-11-00 4-2](#)

SPECIAL TOOLS AND CONSUMABLE MATERIALS

85-00-00-S-35077 Aluminium ruler 1000mm

PRECAUTIONS AND SAFETY MEASURES

WARNING: Do not use permanent marker on anodized (eloxated) parts!

CAUTION: Do not use sticky labels on aluminium or composite parts as they may be difficult to remove!

PROCEDURES

- 1 Inspect for cracks in the blade root area, especially in the area of the inner attachment bore (see Fig. 1 "Critical Area"). In case of any cracks the complete rotor system must be replaced.
- 2 Check each rotor blade in its root section for linearity. In order to do place each rotor blade with the nose section facing down on the support stands and measure gap with an aluminium ruler in 1 m distance from the inner end (see Fig. 2). Maximum allowed gap (dimension A) is 0.5 mm (LTA DULV-2010-004).

IMPORTANT NOTE: In order to avoid measuring errors draw a straight and parallel line 200 mm from the trailing edge. Use a lead pencil. Do not use permanent marker on anodized (eloxated) parts!

ILLUSTRATIONS

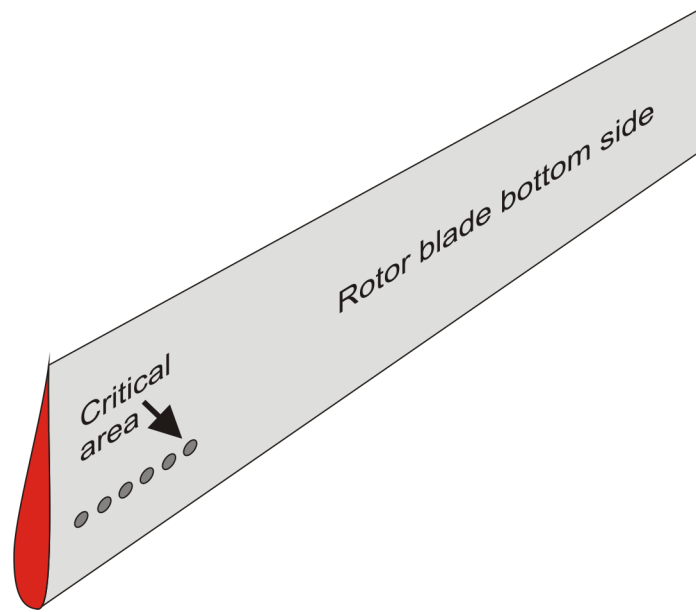

Fig. 1 - Critical blade area

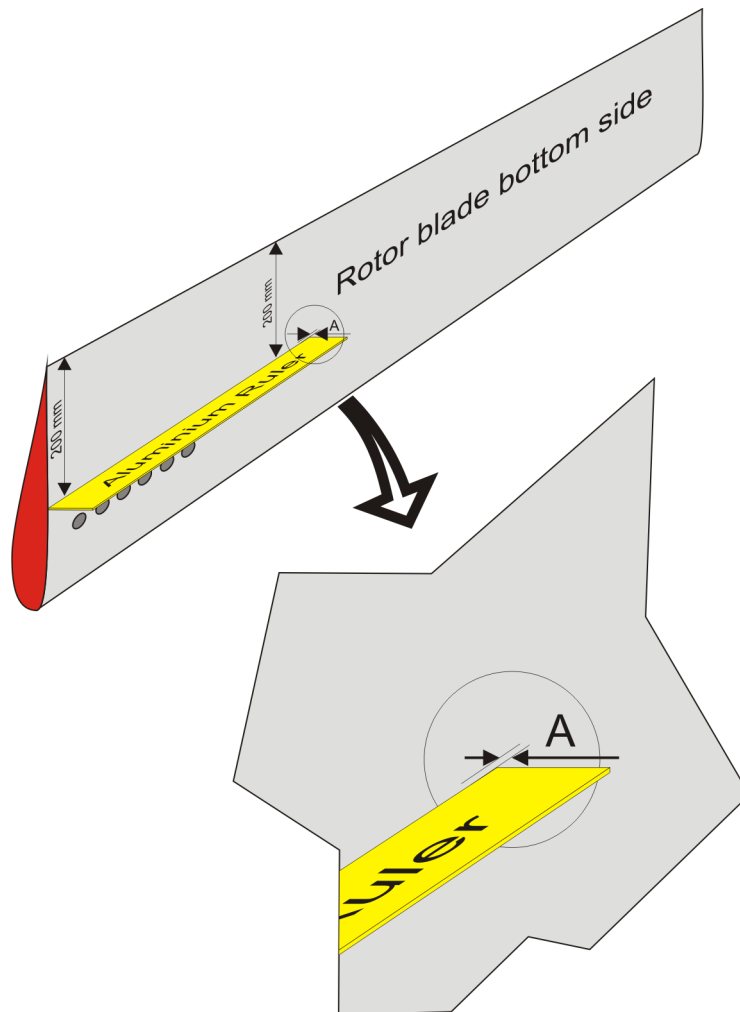

Fig. 2 - Measurement of blade root linearity

62-11-00 6-3 INSPECTION: ROTOR HUB BOLTS

LNE

GENERAL, REFERENCES AND REQUIREMENTS

Task may only be performed by an organization or individual trained and entitled to carry out 'Line Maintenance'!

Rotor system must be removed, see [62-11-00 4-1](#)

Rotor system must be placed on suitable supports to avoid scratching of the blades or bending moments at the blade attachment

SPECIAL TOOLS AND CONSUMABLE MATERIALS

AG-GRS-01 Lagermeister WHS 2002 Grease (88-00-00-S-30477)

LR **IMPORTANT NOTE:** Procedure involves parts with limited reusability. Check parts list below before starting job!

PRECAUTIONS AND SAFETY MEASURES

CAUTION: Remove and re-install only one bolt at a time. Never remove more than one bolt of the installation!

PROCEDURES

- 1 Remove first Rotor Hub Bolt and discard self-locking nut. If necessary use a mandrel and a hammer and tap carefully. Use caution not to damage the threads or the surface of the bore.
- 2 Inspect Rotor Hub Bolt for corrosion. In case of any signs of corrosion the bolt must be replaced.
- 3 Apply a thin layer of AG-GRS-01 on shaft, but NOT on the thread.
- 4 Re-install bolt with a slow turning motion and moderate pressure.
- 5 Install new self-locking nut and pre-torque to approximately 10 Nm.
- 6 Repeat work steps 1 to 5 for the remaining bolts.
- 7 Torque-tighten all Rotor Hub Bolts to the final torque of 25 Nm in opposing/crosswise sequence.

PARTS LIST

Fig.	Pos.	Description	PC PIT	Remark
1	1	M8x60 Rotor blade bolt 8.8 DIN 610	L0 62-00-00-V-20661	
1	2	U9/20	L1 62-00-00-S-33355	
1	3	U8	L1 62-00-00-S-33355	
1	4	M8 Si	L1 62-00-00-S-33355	

ILLUSTRATIONS

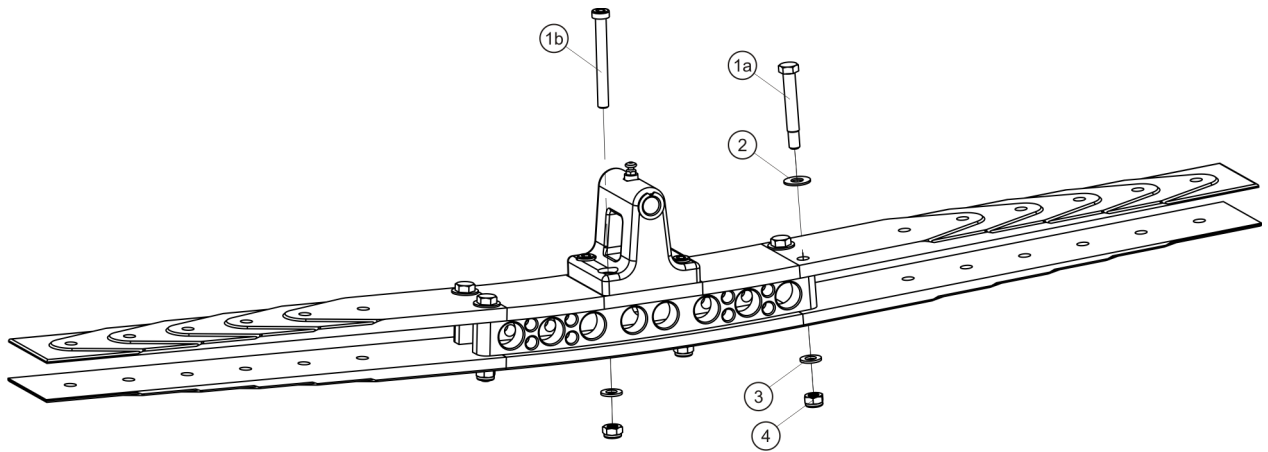

Fig. 1 - Rotor hub

62-11-00 8-1 REPLACEMENT: TEETER BUSHINGS

HVY

GENERAL, REFERENCES AND REQUIREMENTS

Task may only be performed by an organization trained and entitled to carry out 'Heavy Maintenance'!

Rotor system must be removed, see [62-11-00 4-1](#)

SPECIAL TOOLS AND CONSUMABLE MATERIALS

AG-BAS-04 Loctite 638 green (88-00-00-S-30485)

85-00-00-S-36039 Puller bushing teeterblock

PRECAUTIONS AND SAFETY MEASURES

CAUTION: *When removing or disassembling make sure to mark all parts so that each and every part of the component is re-assembled and installed in exactly the same location and orientation!*

PROCEDURES

Removal

CAUTION: *It is advisable to heat up the teeter block in an oven. When removing the teeter block marks all parts or use cable ties so that each and every part of the component is re-assembled and installed in exactly the same location and orientation! This is especially important for the shim plates between teeter block and hub bar.*

WARNING: *Affected aluminium parts must not become warmer than 160 °C.*

- 1 Remove bushings from teeter block. In order to do so warm up teeter block to 120 °C, preferably in an oven.
- 2 Use appropriate tools to drive out bushings. Be careful not to damage the surface of bore.
- 3 Remove bushings from pre-heated teeter tower.
- 4 Use appropriate tools to drive out bushings. Be careful not to damage the surface of bore.

Installation

- 5 Clean bushing seatings / bores from bonding residues and de-grease.
- 6 Teeter block: Apply a thin layer of AG-BAS-04 to bore.
- 7 Press in first bushing with joint/slit facing up. Use a bench vise and press carefully until bushing flange is flush.
- 8 Clean off excessive Loctite, if necessary.
- 9 Repeat step 6 to 8 for second bushing.
- 10 Teeter tower: Apply a thin layer of AG-BAS-04 to bore.
- 11 Press in first bushing with joint/slit facing down. Pull in bushing until flange is flush. Use thick washers on both sides to protect teeter tower and bushing flange from damage.
- 12 Clean off excessive Loctite, if necessary.
- 13 Repeat step 10 to 12 for second bushing.
- 14 If necessary rework inner diameter of bushings in teeter tower with a reamer 13H7.

PARTS LIST

Fig.	Pos.	Description	PC PIT	Remark
1	1	Bushing TEF-MET 13/15/21x15	L0 27-30-00-V-20677	

ILLUSTRATIONS

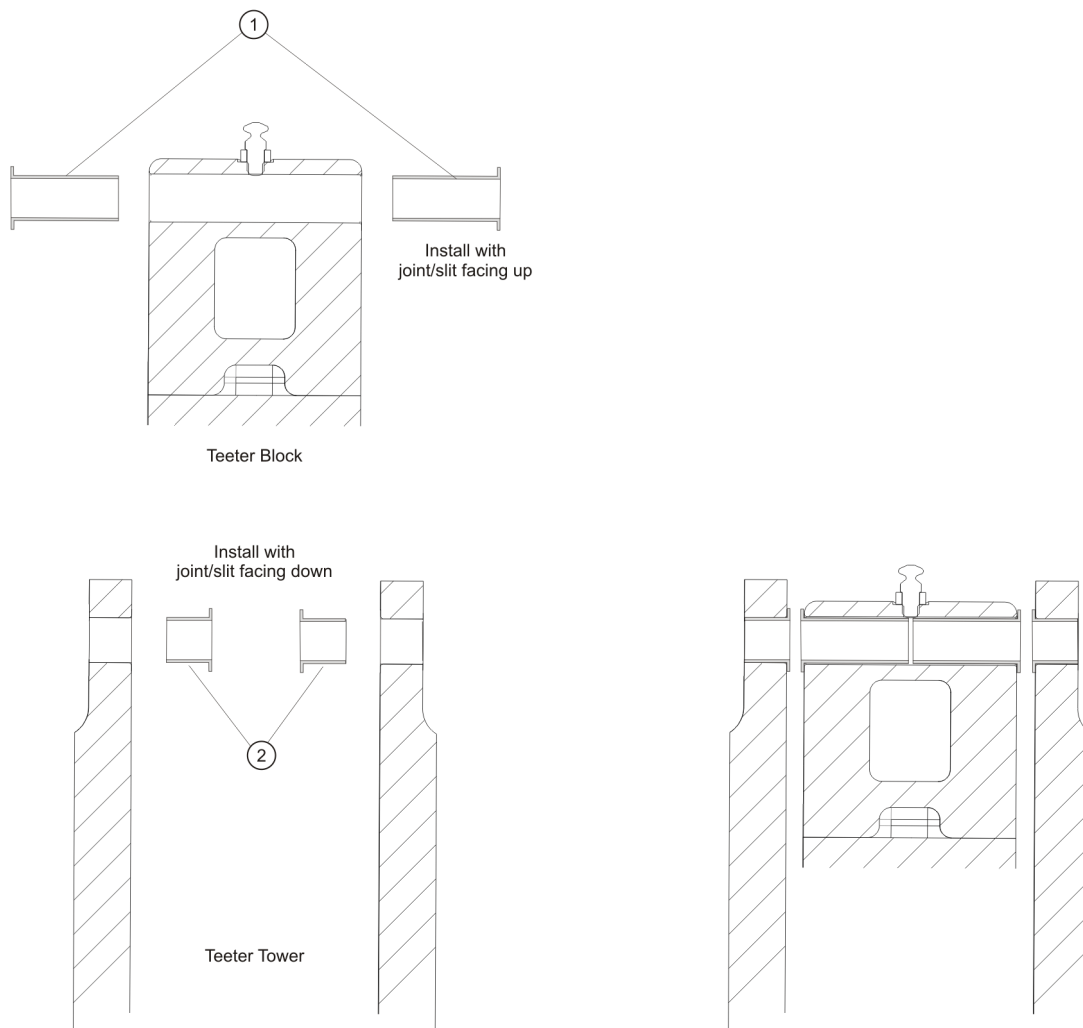
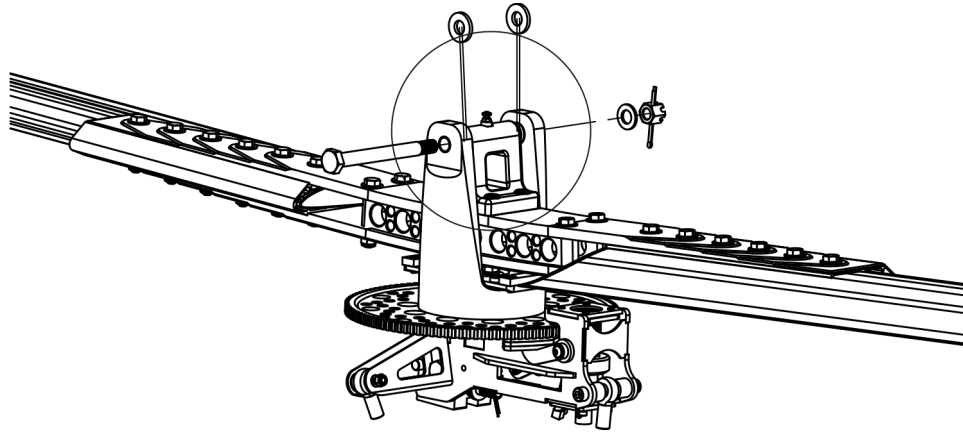

Fig. 1 - Teeter bushings, block and tower - cross section view

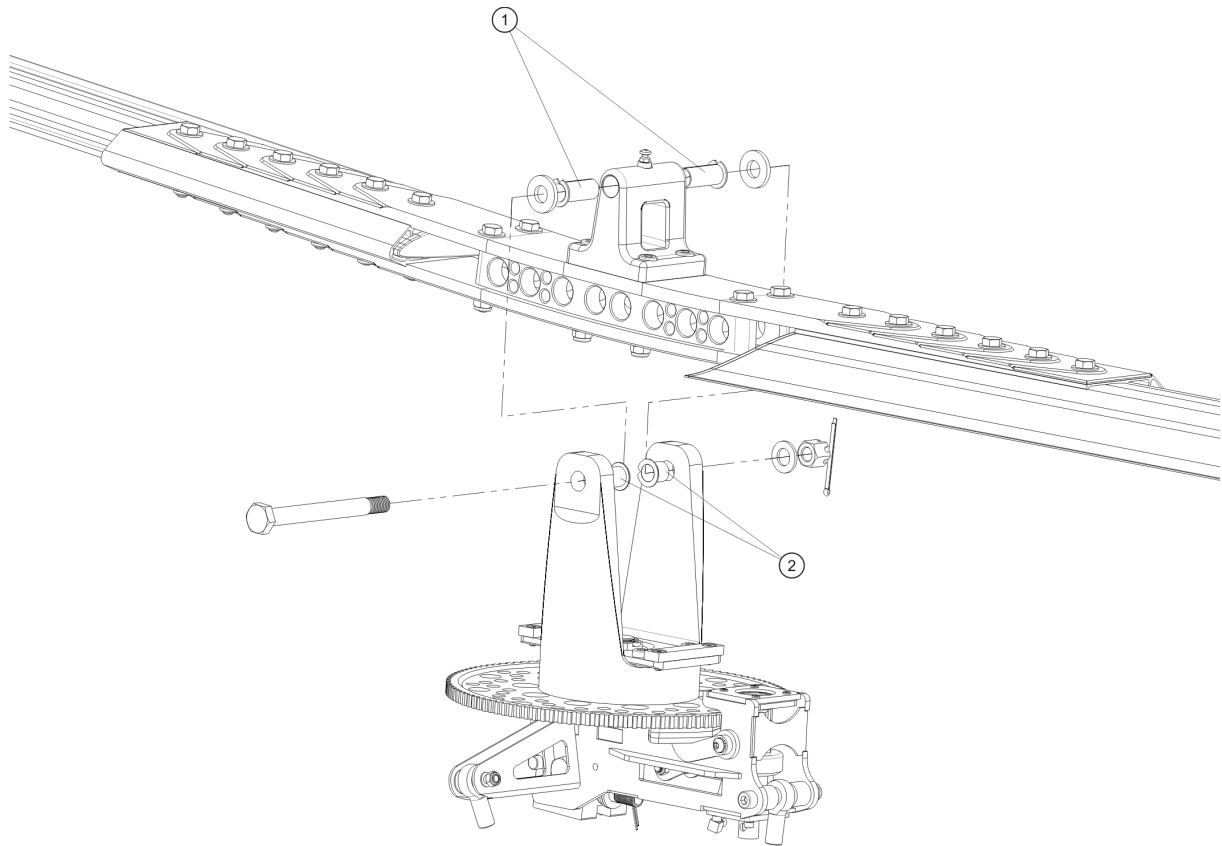

Fig. 2 - Teeter bushings, block and tower - exploded view

62-20-00 8-1 REPLACEMENT: DRIVE GEAR

HVY

GENERAL, REFERENCES AND REQUIREMENTS

Task may only be performed by an organization trained and entitled to carry out 'Heavy Maintenance'!

Secure gyroplane against unauthorized or unintended operation!

Gyroplane must be placed on level ground and restrained (blocks, chocks)

Rotor system must be removed, see [62-11-00 4-1!](#)

SPECIAL TOOLS AND CONSUMABLE MATERIALS

AG-BAS-02 Loctite 243 blue

LR **IMPORTANT NOTE:** Procedure involves parts with limited reusability. Check parts list below before starting job!

PRECAUTIONS AND SAFETY MEASURES

CAUTION: When removing or disassembling make sure to mark all parts so that each and every part of the component is re-assembled and installed in exactly the same location and orientation!

PROCEDURES

- 1 Switch pneumatic mode selector to BRAKE.
- 2 Remove and dispose the split pin (1) (Fig.1 and 2).

WARNING: Wear eye protection when removing attachment hardware!
- 3 Insert a 10mm allen wrench between the rotor head bridge and main bolt head on one side (left or right) (Fig.3).

Note: Use an allen wrench without ball head!
- 4 Determine the exact installation position of the main bolt by moving the allen wrench.

Important: The position of the main bolt is important for the roll tendency of the gyroplane!
- 5 Undo the castle nut (2) (Fig.1 and 2).
- 6 Switch pneumatic mode selector to FLIGHT.
- 7 Remove the castle nut (2) (Fig.1 and 2).
- 8 Remove the teeter tower with the drive gear. Fix the teeter tower in a bench vise carefully.
- 9 Remove and dispose the 6 screws and 6 washers of the drive gear. Remove the drive gear.
- 10 Put new drive gear on teeter tower.
- 11 Apply Loctite 243 to the six screws and six washers of the drive gear. Tighten the screws with a torque of 25 Nm.
- 12 Rotate rotor head so that rotor blades (removed!) would point exactly in flight direction.
- 13 Put teeter tower with new drive gear on the rotor head.
- 14 Align the hole or magnet to the 7 o'clock position in flight direction (Fig.4).
- 15 Make sure that the main bolt is in correct position by moving the 10mm allen wrench (see work step 5).
- 16 Tighten castle nut (2) with a torque value enough to fix the adjustment and of the main bolt.
- 17 Inspect backlash of pre-rotator upper engagement. Backlash should be as tight as possible, but also wide enough to allow easy engagement of the pinion into the sprocket wheel in any position.
- 18 Torque-tighten castle nut (2) with final torque of 120 Nm and re-check position. Apply further torque until the split pin can be inserted.
- 19 Remove the 10 mm allen wrench.

- 20 Insert and secure new split pin (1). Make sure that ends do not contact rotating parts (Fig.2).
- 21 Inspect backlash of pre-rotator upper engagement again. Backlash should be as tight as possible, but also wide enough to allow easy engagement of the pinion into the sprocket wheel in any position.
- 22 Install the rotor system, according to [62-11-00 4-4](#).
- 23 Perform jobcard [63-11-30 6-1](#) "INSPECTION: PRE-ROTATOR UPPER ENGAGEMENT".

PARTS LIST

Fig.	Pos.	Description	PC PIT	Remark
		Splitpins, 10 pieces	L0 27-30-00-S-30261	
		Rotor sprocket mounted	L2 27-30-00-M-36385	
		Kit – Rotor sprocket	L2 27-30-00-S-42957	

ILLUSTRATIONS

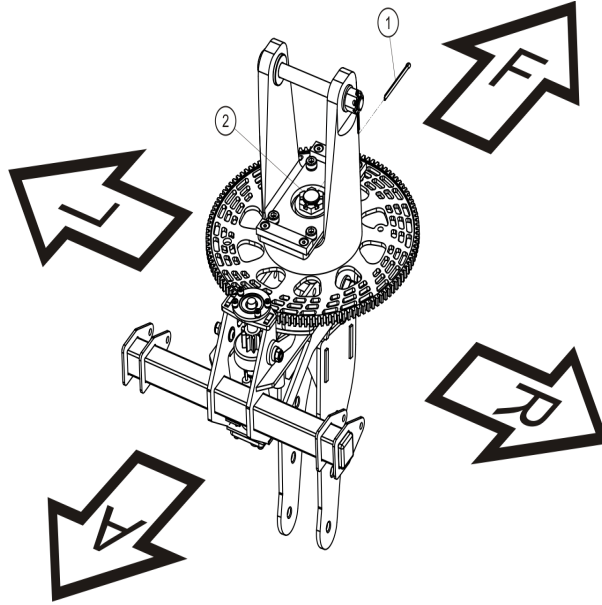

Fig.1 - Rotor head

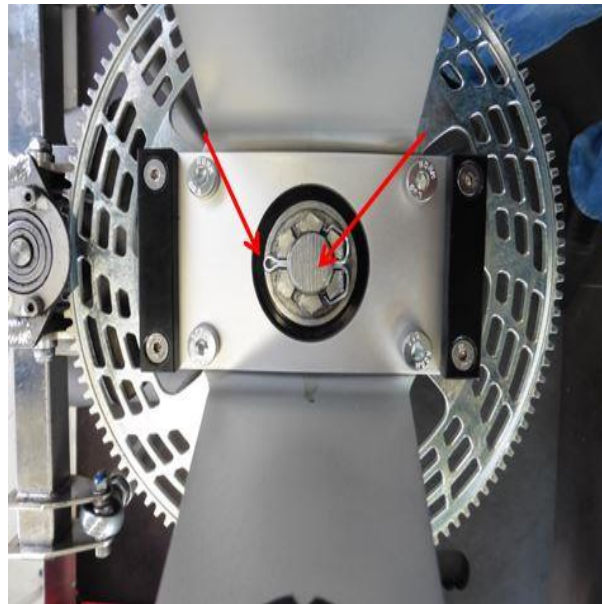

Fig.2 - Split pin and castle nut



Fig.3 - Allen wrench between rotor head and main bolt



Fig.4 - Hole or magnet in the 7 o'clock position in flight direction

62-31-00 5-1 CHECK-ADJUSTMENT: ROTOR HEAD MAIN BOLT AXIS

HVY

GENERAL, REFERENCES AND REQUIREMENTS

Task may only be performed by an organization trained and entitled to carry out 'Heavy Maintenance'!

Secure gyroplane against unauthorized or unintended operation!

Gyroplane must be placed on level ground and restrained (blocks, chocks)

SPECIAL TOOLS AND CONSUMABLE MATERIALS

AG-GRS-01 Lagermeister WHS 2002 Grease (88-00-00-S-30477)

PRECAUTIONS AND SAFETY MEASURES

PROCEDURES

Adjust roll tendency

NOTE:

Roll tendency (tendency to bank increasingly left or right) depends on the flight condition, such as gross mass and altitude, but mainly speed.

Due to the turning direction of the rotor, the gyroplane has a tendency to roll right at slow speeds and roll left at high speeds. In a certain speed range, the gyroplane shows no roll tendency, i.e. flies straight with no lateral control force required.

- 1 Fly with medium gross mass and 120 km/h, or the desired flight condition for which roll tendency shall be adjusted, and find 'no-roll' speed range.
- 2 After landing, measure lateral position of rotor head main bolt axis. Use a feeler gauge or any other method providing an accuracy of at least 0.5 mm.
- 3 Calculate new lateral position assuming 0.5 mm lateral shift (R/L) per 10 km/h intended shift in speed range.

NOTE:

R: to correct roll tendency to the right or to adjust the rotor axis for a slower 'no-roll' speed

L: to correct roll tendency to the left or to adjust the rotor axis for a faster 'no-roll' speed

- 4 Remove and discard split pin (1).
- 5 Untighten castle nut (2) and adjust main bolt to new lateral position. Make sure to maintain longitudinal position (backlash) constant.
- 6 Tighten castle nut (2) with a torque value enough to fixate adjustment and re-check position. If necessary return to step 5.
- 7 Torque-tighten castle nut (2) with final torque of 120 Nm and re-check position. If necessary return to step 5.
- 8 If necessary apply further torque until split pin can be inserted.
- 9 Insert new split pin (1) and secure. Make sure that ends do not contact rotating parts.
- 10 Perform duplicate inspection and test-fly result. If necessary, repeat procedure starting from step 1.
- 11 Perform [63-11-30 6-1](#) "INSPECTION: PRE-ROTATOR UPPER ENGAGEMENT"

Adjust backlash

- 12 Inspect backlash of pre-rotator upper engagement. Backlash should be as tight as possible, but also wide enough to allow easy engagement of the pinion into the sprocket wheel in any position.
- 13 If necessary adjust backlash by performing work steps 14 to 19.
- 14 Remove and discard split pin (1).
- 15 Untighten castle nut (2) and adjust main bolt longitudinal position. Make sure to maintain lateral position (roll tendency) constant.

NOTE:

F: increase pre-rotator backlash (less tight)

A: reduce pre-rotator backlash (tighter)

- 16 Tighten castle nut (2) with a torque value enough to fixate adjustment and re-check position. If position has changed start from step 15.
- 17 Torque-tighten castle nut (2) with final torque of 120 Nm and re-check position. If necessary return to step 15.
- 18 If necessary apply further torque until split pin can be inserted.
- 19 Insert new split pin (1) and secure. Make sure that ends do not contact rotating parts.
- 20 Perform duplicate inspection.

ILLUSTRATIONS

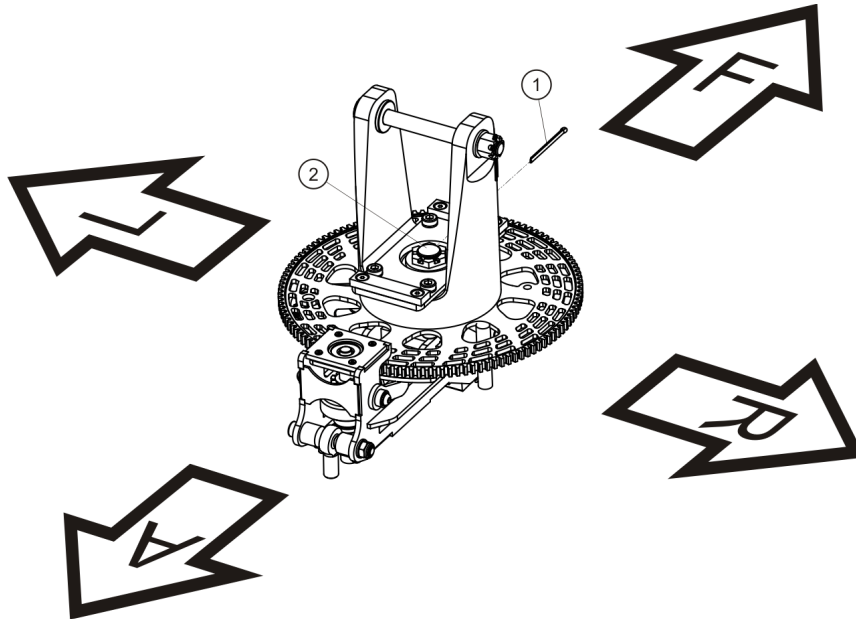

Fig. 1 - Adjustment of rotor head main bolt axis

62-31-00 6-1 INSPECTION: ROTOR HEAD BRIDGE, BEARING AND TEETER TOWER

LNE

GENERAL, REFERENCES AND REQUIREMENTS

Task may only be performed by an organization or individual trained and entitled to carry out 'Line Maintenance'!

Mast cover must be removed, see [52-00-00 4-1](#)

SPECIAL TOOLS AND CONSUMABLE MATERIALS

LR **IMPORTANT NOTE:** Procedure involves parts with limited reusability. Check parts list below before starting job!

PRECAUTIONS AND SAFETY MEASURES

WARNING: Wear eye protection and mind FOD when removing attachment hardware!

PROCEDURES

- 1 Inspect rotor head bridge (5) function and condition, i.e. no misalignment, dents, nicks, corrosion, or cracks. In case of any of the aforementioned is evident or suspected contact AutoGyro customer support.
- 2 Inspect teeter stops (4) for correct attachment and condition.
- 3 Inspect teeter tower (3) for correct attachment and condition, i.e. no cracks. In case of cracks or unusual condition or appearance contact AutoGyro customer support.
- 4 Perform torque-check on main bolt nut (2). In order to do so, remove and discard split pin (1) and torque-check castle nut with 120 Nm.
- 6 If torque-check fails mark component / gyroplane unserviceable and contact AutoGyro customer support.
- 7 Insert new split pin (1) and secure. Make sure that ends do not contact rotating parts.

WARNING: Do not fly gyroplane in case torque-check failed. Clearly mark as unserviceable and prevent from use until resolved.

PARTS LIST

Fig.	Pos.	Description	PC PIT	Remark
1	1	Splitpins, 10 pieces	L0 27-30-00-S-30261	
1	2	M20 castle nut flat	NPI	
1	3		27-30-00-V-33433	
1	4		27-30-00-V-33433	
1	5	Rotorhub bottom mounted	NPI	
1	6	M20x1_5x73,8	NPI	

ILLUSTRATIONS

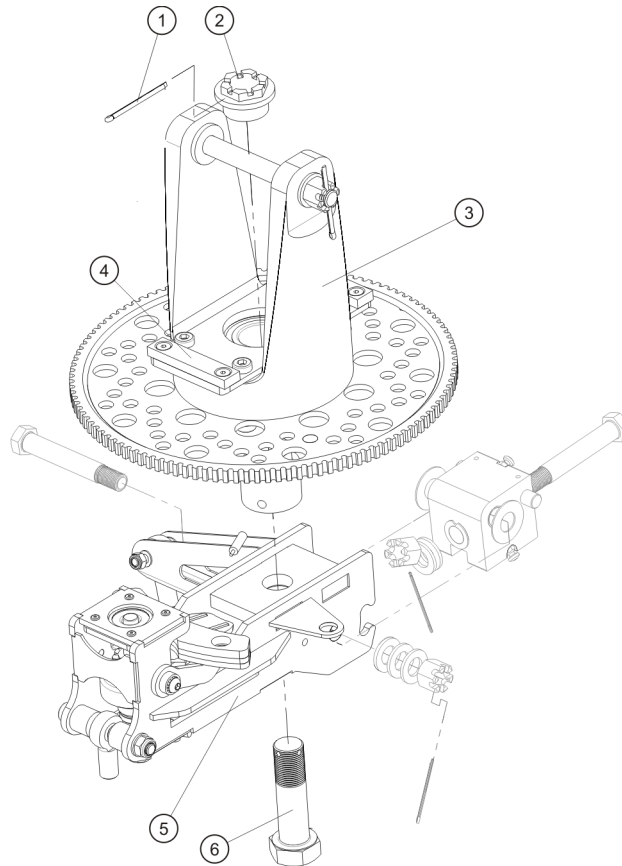

Fig. 1 - Rotor head bridge, bearing and teeter tower

62-32-00 5-1 CHECK-ADJUSTMENT: ROTOR CONTROL FRICTION

HVY

GENERAL, REFERENCES AND REQUIREMENTS

Task may only be performed by an organization trained and entitled to carry out 'Heavy Maintenance'!

Rotor head bridge / gimbal head configuration state must conform to version II

Rotor system must be removed, see [62-11-00 4-1](#)

SPECIAL TOOLS AND CONSUMABLE MATERIALS

85-00-00-S-34115 Spring balance / Dynamometer

PRECAUTIONS AND SAFETY MEASURES

PROCEDURES

- 1 Switch pneumatic mode selector to flight and release trim pressure completely. If necessary, switch repeatedly!
- 2 Attach spring balance / dynamometer as shown in Fig. 1 and pull carefully until control stick starts to move. Note maximum value (breakout force).
- 3 Breakout force can be adjusted by tightening the gimbal head pitch bolt. If the split pin drill of the gimbal head pitch bolt is covered by the castle nut, place shim washers between the washers (Fig. 2, Pos. 10). Note: 0.1 mm shim washer equates approximately 20° nut rotating angle.
- 4 Rotor vibration levels will decrease with higher control friction, but handling qualities will suffer, if control friction is too high. Friction should not exceed 10 N, with an absolute maximum of 15 N!
- 5 After completion, switch pneumatic mode selector to BRAKE, apply brake pressure and secure rotor system.

PARTS LIST

Fig.	Pos.	Description	PC PIT	Remark
2	1	ROLL/PITCH BOLT	L2 27-30-00-V-20675	
2	2	axial bushing 14	NPI	
2	3	disc spring 12,2X25,0X0,9 drilled 14,5	NPI	
2	4	Gimbal head II	L2 57-00-00-S-33615	
2	5	U13	NPI	
2	6	M12 castle nut	NPI	
2	7	Split pin 3.2x50	NPI	
2	8	ROLL/PITCH BOLT	L2 27-30-00-V-20675	
2	9	U13	NPI	
2	10	M12 castle nut	NPI	
2	11	Split pin 3.2x50	NPI	

ILLUSTRATIONS



Fig. 1 - Measurement of rotor control friction

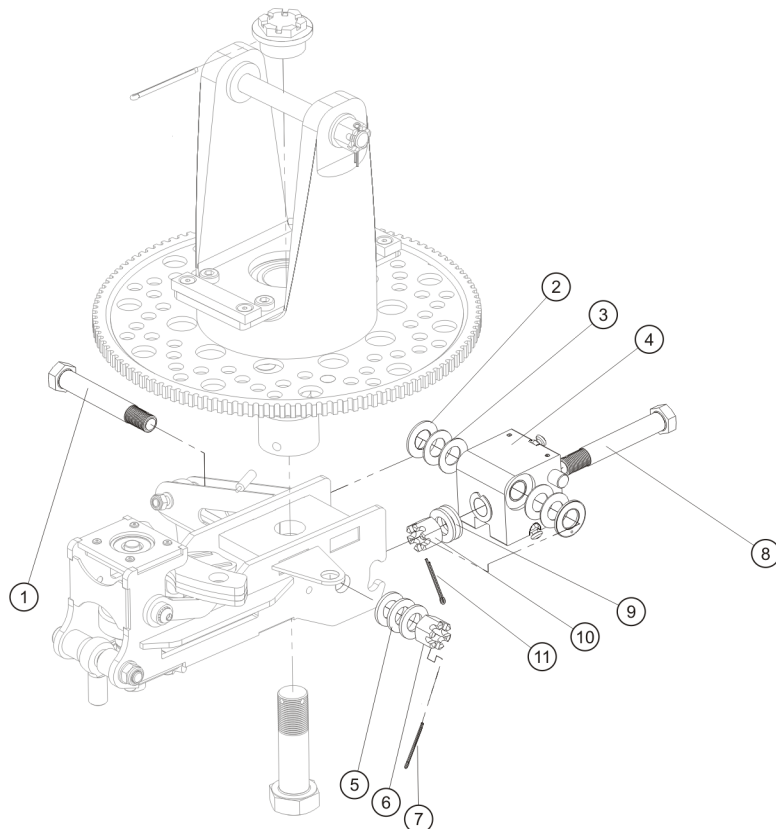

Fig. 2 - Gimbal head assembly, Rotor System II (with spring washers)

62-32-00 6-1 INSPECTION: ROTOR GIMBAL HEAD

LNE

GENERAL, REFERENCES AND REQUIREMENTS

Task may only be performed by an organization or individual trained and entitled to carry out 'Line Maintenance'!

Rotor system must be removed, see [62-11-00 4-1](#)

SPECIAL TOOLS AND CONSUMABLE MATERIALS

AG-GRS-01 Lagermeister WHS 2002 Grease (88-00-00-S-30477)

85-00-00-S-31438 Inklinometer / Digital Spirit Level

PRECAUTIONS AND SAFETY MEASURES

PROCEDURES

- 1 Inspect gimbal head (4) for correct function and condition, i.e. check split pin (7) and (11) is installed and no play at the hinge points is evident.
- 2 Verify angles of gimbal head mechanical end stops. In order to do so perform the following work steps:
- 3 Place gyroplane on level ground with zero roll attitude and centre console horizontal.
- 4 Rotate rotor head so that rotor blades (removed!) would point exactly fore-aft. Place inclinometer on top of teeter tower and measure RH and LH end stop angle. Make sure that mechanical stops are reached. Record values.
- 5 Rotate rotor head so that rotor blades (removed!) would point exactly left-right. Place inclinometer on top of teeter tower and measure FORE and AFT end stop angle. Make sure that mechanical stops are reached. Record values.
- 6 Verify measured angles comply with the values specified in the corresponding type certificate data sheet. If any of the values differs by more than 1° from the specified value mark component unserviceable and contact AutoGyro customer support.

PARTS LIST

Fig.	Pos.	Description	PC PIT	Remark
1	1	ROLL/PITCH BOLT	L2 27-30-00-V-20675	
1	2	axial bushing 14	NPI	
1	3	disc spring 12,2X25,0X0,9 drilled 14,5	NPI	
1	4	Gimbal head II	L2 57-00-00-S-33615	
1	5	U13	NPI	
1	6	M12 castle nut	NPI	
1	7	Split pin 3.2x50	NPI	
1	8	ROLL/PITCH BOLT	L2 27-30-00-V-20675	
1	9	U13	NPI	
1	10	M12 castle nut	NPI	
1	11	Split pin 3.2x50	NPI	

ILLUSTRATIONS

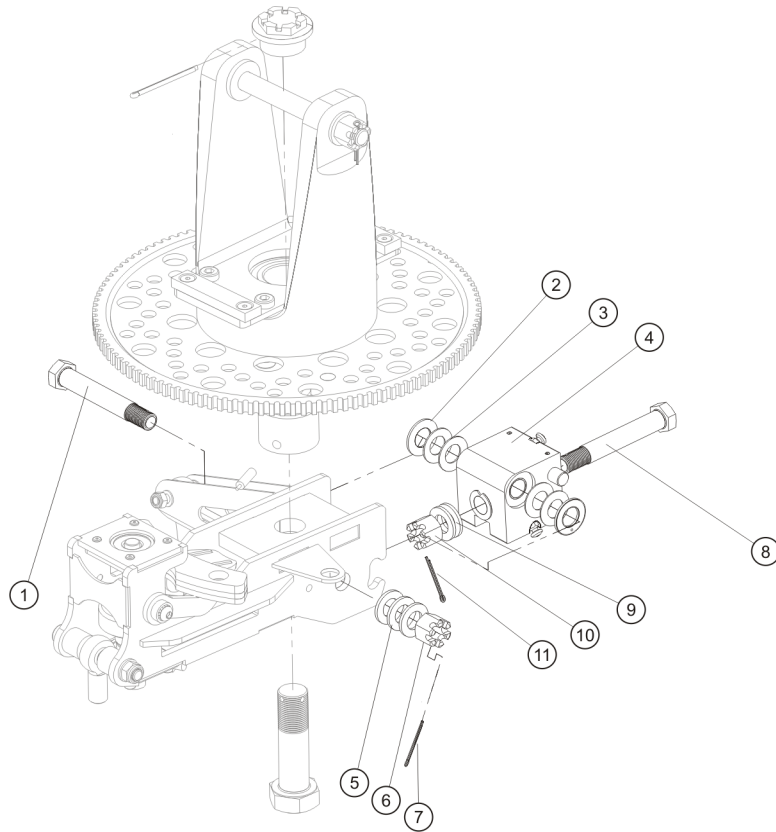

Fig. 1 - Rotor gimbal head - Version II

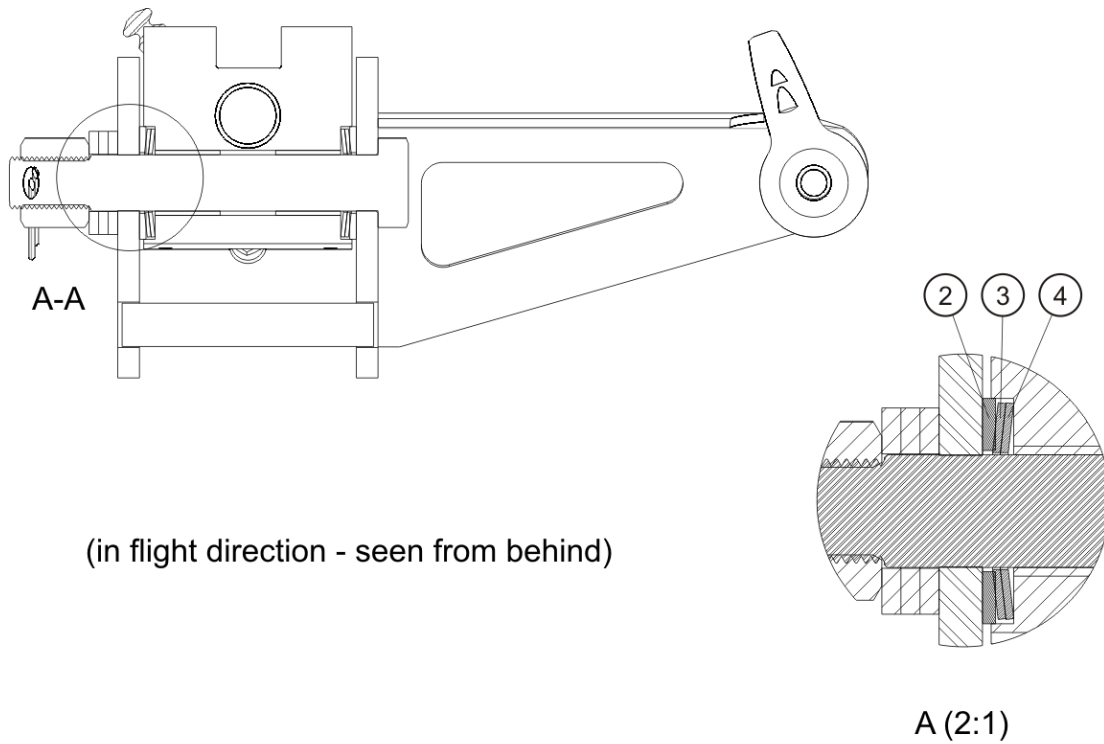

Fig. 2 - Arrangement of spring washers on gimbal head - Version II

62-51-00 4-1 REMOVAL-INSTALLATION: TOP MAST

HVY

GENERAL, REFERENCES AND REQUIREMENTS

Task may only be performed by an organization trained and entitled to carry out 'Heavy Maintenance'!

Secure gyroplane against unauthorized or unintended operation!

A suitable stand should be used if possible!

Self-locking nuts and split pins must only be used once and discarded! Check availability of new hardware before commencing work!

Rotor system must be removed, see [62-11-00 4-1](#)

Mast cover must be removed, see [52-00-00 4-1](#)

SPECIAL TOOLS AND CONSUMABLE MATERIALS

AG-BAS-01	Loctite 221 red (88-00-00-S-30487)
AG-BAS-02	Loctite 243 blue (88-00-00-S-30483)
AG-GRS-01	Lagermeister WHS 2002 Grease (88-00-00-S-30477)
AG-LUB-03	Würth HHS2000 Oil Spray (88-00-00-S-30476)

PRECAUTIONS AND SAFETY MEASURES

WARNING: Safety Critical Part - May have catastrophic consequences when component or part is missing, damaged, or handled incorrectly!

WARNING: Job includes work at critical flight controls. Duplicate inspection must be performed after completion!

WARNING: Object is heavy! Inadequate handling could cause injury. Use proper lifting techniques or assistance!

WARNING: When working with cranes or other lifting equipment the general safety regulations have to be respected at all times!

CAUTION: When removing or disassembling make sure to mark all parts so that each and every part of the component is re-assembled and installed in exactly the same location and orientation!

PROCEDURES

Removal

- 1 Disconnect temperature sensor and rotor rpm sensor, remove cable ties on top mast (Fig. 1).
- 2 Disconnect pneumatic hoses from Bendix pneumatic actuator, roll trim actuator and pitch trim actuator (Fig. 2, Fig. 3).

CAUTION: When removing or disassembling make sure to mark all parts so that each and every part of the component is re-assembled and installed in exactly the same location and orientation!

- 3 Remove bolt (Fig. 4) from roll control and roll trim. Maintain attachment hardware, discard self-locking nut!

CAUTION: When removing or disassembling make sure to mark all parts so that each and every part of the component is re-assembled and installed in exactly the same location and orientation!

- 4 Remove bolt (Fig. 5) from pitch control. Maintain attachment hardware, discard self-locking nut!

IMPORTANT NOTE: When disconnecting the push-pull cable bulkhead at the top mast, unscrew only top (outer) attachment nut and leave lower (inner) attachment nut unchanged and mark position.

- 5 Disconnect roll push-pull cable bulkhead. In order to do so, unscrew and remove top (outer) attachment nut

(Fig. 6).

- 6 Disconnect pitch push-pull cable bulkhead. In order to do so, unscrew and remove top (outer) attachment nut.
- 7 Remove mast bushes (Fig. 7) and free mast bushes from grease residuals.
- 8 Pull top mast equipped with rotor head out of mast bottom. Lead push-pull control cables through attachment consoles and pneumatic hose package through the inside of the pitch console.

Installation

- 9 If applicable remove transport securing devices.
- 10 Insert top mast equipped with rotor head into mast bottom. Lead push-pull control cables through attachment consoles (Fig. 8)
- 11 Lubricate pre-rotator drive with oil with AG-LUB-03 (spray in top pre rotator drive shaft) and insert lower sliding splined drive shaft into top pre-rotator drive shaft (Fig. 9)
- 12 Equip each threaded mast bush with a washer disc and a screw, grease mast bushes (AG-GRS-01) and push into their designated openings as follows: Short mast bush in the upper opening, long mast bush in lower opening. Equip each mast bush on opposite also with a washer disc and a screw. Apply Loctite 243 (AG-BAS-02) on each screw thread and torque-tighten with standard bolt torque (Fig. 7).

IMPORTANT NOTE: When re-installing push-pull cable bulkhead make sure that the lower (inner) attachment nut remains in original (marked) position.

- 13 Equip roll push-pull control cable bulkhead with a serrated washer and a counter nut. Torque-tighten counter nut with 25 Nm and apply securing paint (Fig. 6).
- 14 Equip pitch push-pull control cable bulkhead with a serrated washer and a counter nut. Torque-tighten counter nut with 25 Nm and apply securing paint.
- 15 Re-install pitch control ball joint (Fig. 5). In order to do so, insert bolt from left and install
 - 1) spacer
 - 2) ball joint
 - 3) spacer
 Secure with new locking nut and torque-tighten.
- 16 Re-install roll control ball joint and roll trim (Fig. 4). In order to do so, insert bolt from front and install
 - 1) plastic washer
 - 2) ball joint roll control
 - 3) small washer
 - 4) spacer
 - 5) ball joint trim actuator
 - 6) spacer
 - 7) large washer
 Secure with new locking nut and torque-tighten.
- 17 Pull pneumatic hose package through the inside of the pitch console and fix with cable-ties (Fig. 3).
- 18 Apply Loctite 221 (AG-BAS-01) on pneumatic connection threads of roll trim actuator actuator and pitch trim actuator. Connect pneumatic hoses according to Fig. 3. Tighten union nuts of pneumatic hoses slightly with pliers and fix hoses with cable ties. Prevent chafing of pneumatic hoses!
- 19 Connect temperature sensor and rotor rpm sensor, lead cable on the right side of the mast. Fix cable according to Fig. 1 with cable ties.
- 20 Move flight control stick carefully to all directions (full deflections) in order to ensure an installation without strain or stresses.
- 21 Inspect rotor gimbal head according to [62-32-00 6-1](#) and check/adjust rotor control angles.

ILLUSTRATIONS



Fig. 1 - Temperature sensor



Fig. 2 - Pneumatic connection Bendix

- Brake-trim-actuator top - clear
- Roll-trim-actuator top - clear / black
- Roll-trim-actuator bottom - blue / black
- Brake-trim-actuator bottom - blue



Fig. 3 - Pneumatic hoses



Fig. 4 - Roll control



Fig. 5 - Pitch control

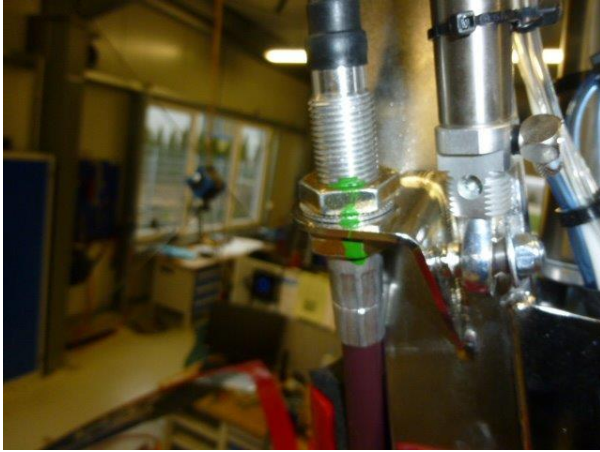

Fig. 6 - Push-pull control cable bulkhead attachment



Fig. 7 - Installation of **mast bushes**

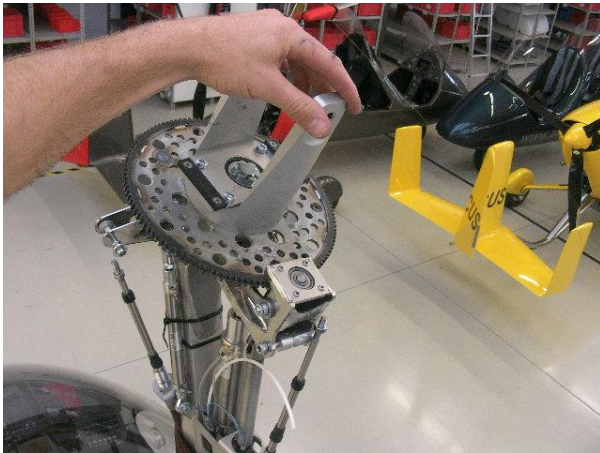

Fig. 8 - Top mast

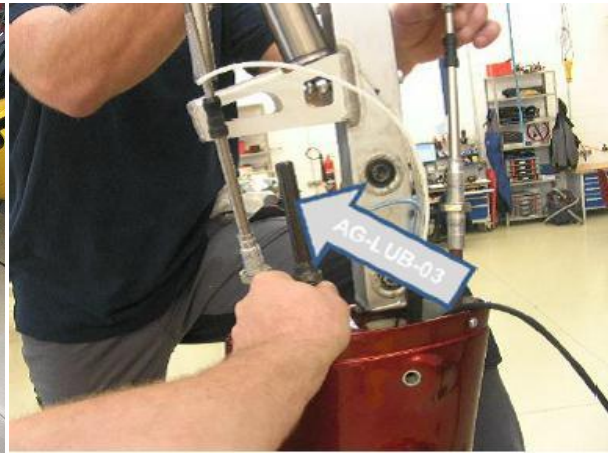

Fig. 9 - Pre-rotator drive

62-51-00 6-1 INSPECTION: MAST MOUNTING BUSHINGS

LNE

GENERAL, REFERENCES AND REQUIREMENTS

Task may only be performed by an organization or individual trained and entitled to carry out 'Line Maintenance'!

Rotor system must be removed, see [62-11-00 4-1](#)

Secure gyroplane against unauthorized or unintended operation!

Gyroplane must be placed on level ground and restrained (blocks, chocks)

A suitable stand should be used if possible!

Work should be performed with the aid of a second briefed person!

SPECIAL TOOLS AND CONSUMABLE MATERIALS

85-00-00-S-34115 Spring balance / Dynamometer

PRECAUTIONS AND SAFETY MEASURES

PROCEDURES

- 1 Neutral mast position, no force applied: Measure diagonal distance from mast reference point to fuselage reference point (see illustrations in Fig. 1) and record value 'A' in protocol.
- 2 Repeat measurement with 150 N, applied horizontally in flight direction (see Fig. 1). Record value 'B' in protocol.
- 3 Calculate deflection value 'A-B' and record in protocol. If deflection 'A-B' exceeds 5 mm, contact AutoGyro customer support.
- 4 If advised by AutoGyro, repeat measurement with 150 N, applied against flight direction (see Fig. 1).

ILLUSTRATIONS

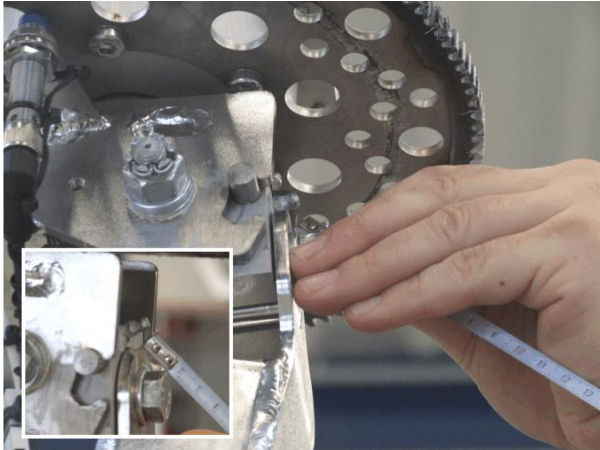

Fig. 1 - Mast reference point



Fig. 2 - Fuselage reference point



Fig. 3 - Force applied against flight direction



Fig. 3 - Force applied in flight direction

62-51-00 8-1 REPLACEMENT: MAST MOUNTING BUSHINGS

HVY

GENERAL, REFERENCES AND REQUIREMENTS

Task may only be performed by an organization trained and entitled to carry out 'Heavy Maintenance'!

Secure gyroplane against unauthorized or unintended operation!

Gyroplane must be placed on level ground and restrained (blocks, chocks)

Rotor system must be removed, see [62-11-00 4-1](#)

A suitable stand should be used if possible!

SPECIAL TOOLS AND CONSUMABLE MATERIALS

AG-BAS-04	Loctite 638 green (88-00-00-S-30485)
AG-GRS-01	Lagermeister WHS 2002 Grease (88-00-00-S-30477)
AG-LUB-03	Würth HHS2000 Oil Spray (88-00-00-S-30476)

PRECAUTIONS AND SAFETY MEASURES

WARNING: *Job includes work at critical flight controls. Duplicate inspection must be performed after completion!*

CAUTION: *When removing or disassembling make sure to mark all parts so that each and every part of the component is re-assembled and installed in exactly the same location and orientation!*

IMPORTANT NOTE: *Before disconnecting and removing push-pull cables, mark position of (inner) counter nut and ball end in order to avoid re-adjustment (rigging) of flight controls!*

PROCEDURES

- 1 Disconnect rod end of roll control push-pull cable at upper attachment point.
- 2 Disconnect rod end of pitch control push-pull cable at upper attachment point.

NOTE: *When disconnecting the push-pull cable bulkhead at the top mast, unscrew only top (outer) attachment nut and leave lower (inner) attachment nut unchanged.*
- 3 Disconnect roll push-pull cable bulkhead. In order to do so, unscrew and remove top (outer) attachment nut.
- 4 Disconnect pitch push-pull cable bulkhead. In order to do so, unscrew and remove top (outer) attachment nut.
- 5 Disconnect sensor cable from rotor speed sensor, pneumatic hoses from pneumatic cylinders and remove respective cable ties.
- 6 Support the upper mast (using a crane or suitable lifting device) and remove mast attachment hardware.
- 7 Screw-in an 8 x 120 mm bolt and drive out rubber bushing sleeves using a rubber hammer.
- 8 Make sure all support lines, cables and controls are safely disconnected and out of the way. Carefully pull out upper mast
- 9 Heat up seatings of rubber bushings with a heat gun and push out rubber bushings using appropriate tools.
- 10 Clean inner bores from residual Loctite and degrease with brake cleaner.
- 11 Clean outer surface of new bushings. Use abrasive cloth to ensure clean, metallic surface.
- 12 Check that bushings can be inserted tightly into bores. If necessary, rework outer surface of bushing.
- 13 Apply AG-BAS-04 (Loctite 638) on outer surface of bushings and install bushings in upper mast. Bushings shall be centred so that they extend equally to both sides.
- 14 Remove excessive Loctite. Use brake cleaner, if needed.
- 15 Apply AG-LUB-03 to pre-rotator drive coupling sleeve and position upper mast. Make sure that coupling sleeve joins easily.

- 16 Apply AG-GRS-01 on outer surface of bushing sleeves and install bushing sleeves. Use a rubber hammer, if required.
- 17 Install attachment hardware and torque-tighten with 20 Nm. Mark bolt heads with securing paint.
- 18 Re-install push-pull cable bulkhead and rod end for roll control. Mark attachment hardware with securing paint.
- 19 Re-install push-pull cable bulkhead and rod end for pitch control. Mark attachment hardware with securing paint.
- 20 Re-connect support lines and cables. Secure support lines and cables with cable ties.
- 21 Have duplicate inspection performed on correct attachment of flight controls, i.e. push-pull cables and attachments.

WARNING: The ball joint must be installed with at least 8 threads on the rod end of the push-pull control cable .

- 22 Check rotor head control angles [62-32-00 6-1](#) and re-adjust, if necessary.

PARTS LIST

Fig.	Pos.	Description	PC	PIT	Remark
------	------	-------------	----	-----	--------

ILLUSTRATIONS

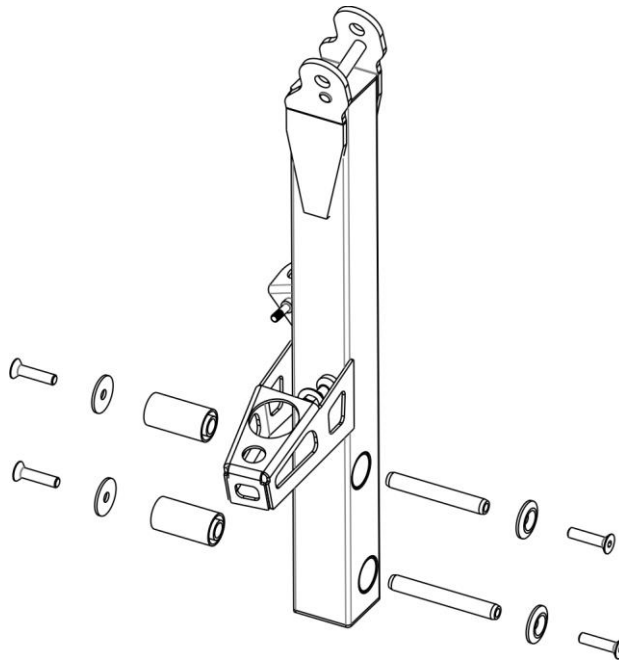

Fig. 1 - Bottom mast with mast mounting bushings

63-11-10 4-1 REMOVAL-INSTALLATION: PRE-ROTATOR CLUTCH

HVY

GENERAL, REFERENCES AND REQUIREMENTS

Task may only be performed by an organization trained and entitled to carry out 'Heavy Maintenance'!

Secure gyroplane against unauthorized or unintended operation!

Engine cowlings must be removed, see [52-00-00 4-1](#)

SPECIAL TOOLS AND CONSUMABLE MATERIALS

AG-BAS-02 Loctite 243 blue (88-00-00-S-30483)

LR **IMPORTANT NOTE:** Procedure involves parts with limited reusability. Check parts list below before starting job!

PRECAUTIONS AND SAFETY MEASURES

PROCEDURES

Removal

- 1 Remove hoses from oil reservoir and seal open ends against contamination.
- 2 Remove oil reservoir.
- 3 Loop a lifting belt around the propeller/gearbox shaft and take the load off the engine mounts using appropriate lifting equipment.

NOTE: Both engine mounts in the LH side remain in place.

- 4 Unscrew and remove 2 x attachment hardware of engine mounts on RH side. Discard self-locking nuts.
- 5 With the engine weight unloaded, tilt engine around remaining LH engine mounts as far as necessary (do not overstretch rubber bushings) in order to get access to the pneumatic clutch.
- 6 Disconnect pneumatic hose at quick connect coupling.
- 7 Cut open and discard affected cable ties.
- 8 Unscrew and remove 4 x M6 bolts and remove pneumatic clutch with attach ring.

NOTE: Do not separate attach ring from clutch and let adapter frame remain on engine.

- 9 Remove pneumatic clutch by pulling apart sliding shaft coupling.

Installation

- 10 Insert sliding shaft coupling and position pneumatic clutch with attach ring on adapter frame.
- 11 Apply AG-BAS-02 on threads and torque-tighten 4 x M6 bolts with 10 Nm.
- 12 Check that vertical pre-rotator drive can be easily turned by hand.
- 13 Re-connect pneumatic hose at quick connect coupling. Make sure flow control valve is in place and installed in correct flow direction (blue line to clutch, white line to pneumatic box).
- 14 Perform functional check (engine off) and monitor clutch actuation.

EFFECTIVITY: Pneumatic Clutch III

- 15 Check clutch activation pressure 5 bar +/- 0.1
- 16 Re-install engine mounts. Use new self-locking nuts and torque-tighten.
- 17 Remove lifting belt.
- 18 Install oil reservoir.
- 19 Remove seals and re-connect oil hoses to reservoir.

63-11-10 5-1 CHECK-ADJUSTMENT: PRE_ROTATOR CLUTCH

LNE

GENERAL, REFERENCES AND REQUIREMENTS

Task may only be performed by an organization or individual trained and entitled to carry out 'Line Maintenance'!

Secure gyroplane against unauthorized or unintended operation!

Rotor system must be removed, see [62-11-00 4-1](#)

Engine cowlings must be removed, see [52-00-00 4-1](#)

Mast cover must be removed, see [52-00-00 4-1](#)

SPECIAL TOOLS AND CONSUMABLE MATERIALS

AG-LUB-03 Würth HHS2000 Oil Spray (88-00-00-S-30476)

85-00-00-S-35145 Adjusting Tool Pre-Rotator (CV)

85-00-00-S-36114 Adjusting Scale Pre-Rotator Clutch (CV)

PRECAUTIONS AND SAFETY MEASURES

PROCEDURES

- 1 Remove shear bolt between Bendix shaft and upper pre-rotator drive (Fig. 1), remove upper pre-rotator drive.
- 2 Remove M8x20 screw plug with seal ring from the crankcase. Turn the crankshaft by propeller into top dead centre (TDC) position of cylinder 1 and 2. TDC can be checked with the aid of a lamp through the opening of the removed screw. When the crankshaft is in correct position screw thread pin (Fig. 2) so that the crankshaft is blocked.
- 3 Connect check valve to pressure reducer (see Fig. 3), free flow through check valve in direction to pressure reducer.
- 4 Install pressure gauge with T-piece between pre-rotator clutch and pressure reducer (Fig. 4).
- 5 Switch pneumatic mode selector to FLIGHT, activate and hold pre-rotator until compressor stops working. The pressure gauge connected between the pre-rotator clutch and the pressure reducer must display about 5 bar.

IMPORTANT NOTE: For the following measurement, ensure that pre-rotator spline shaft is in a vertical position and that scale and adjusting lever form a right angle.

- 6 Slide adjusting lever on the pre-rotator spline shaft, hook scale in adjusting lever and pull scale until the clutch slips noticeably (Fig. 5). Scale must display a breakout force of 80 N \pm 5 N (or a breakout torque on the spline shaft of 40 Nm \pm 2.5 Nm)
- 7 If necessary adjust pre-rotator clutch via knurled nut on the pressure reducer (Fig. 6) until a breakaway force of 80 N \pm 5 N is achieved on the adjusting lever. Secure adjustment with knurled nut.
Upon finalisation a pressure between 5 and 7 bar should be readable on the pressure gauge. If the given values are not achieved execute [63-11-10 6-1](#).
- 8 Remove all adjustment tools and auxiliary devices from the gyroplane, reconnect pneumatic hoses to the pressure reducer (Fig. 6).
- 9 Switch pneumatic mode selector to BRAKE.
- 10 Remove thread pin. Install screw plug with new copper seal ring and tighten with a torque of 15 Nm. For checking, carefully turn propeller by hand.
- 11 Lubricate pre-rotator spline shaft with AG-LUB-03, insert upper pre-rotator drive, install shear bolt between Bendix shaft and upper pre-rotator drive (Fig. 1).

ILLUSTRATIONS



Fig. 1 - Upper pre-rotator drive connected to Bendix shaft



Fig. 2 - Thread Pin M8x50

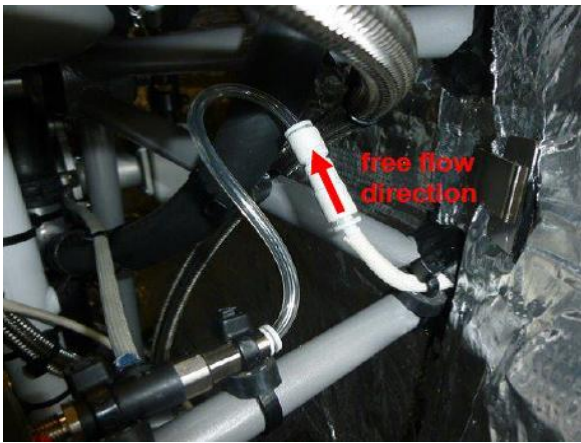

Fig. 3 - Connection of check valve to pressure reducer



Fig. 4 - Connection between clutch and pressure reducer

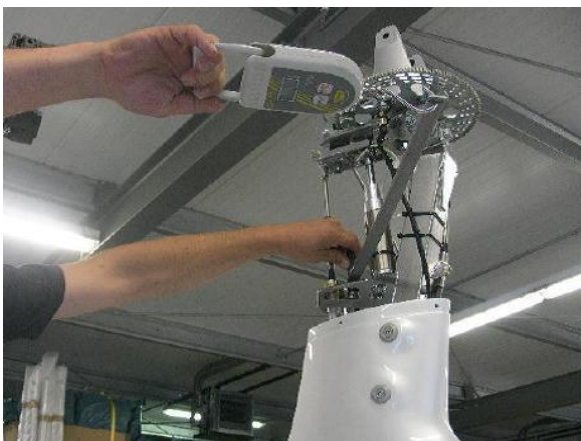

Fig. 5 - Measurement of breakout torque



Fig. 6 - Pressure reducer

63-11-10 6-1 INSPECTION: PRE-ROTATOR CLUTCH

LNE

GENERAL, REFERENCES AND REQUIREMENTS

Task may only be performed by an organization or individual trained and entitled to carry out 'Line Maintenance'!

Secure gyroplane against unauthorized or unintended operation!

Engine cowlings must be removed, see [52-00-00 4-1](#)

SPECIAL TOOLS AND CONSUMABLE MATERIALS

None

PRECAUTIONS AND SAFETY MEASURES

PROCEDURES

- 1 Check wear state of clutch lining. Wear mark (groove in the lining) must be recognizable. See Fig. 1, dimension A. Replace clutch if necessary.
- 2 Measure clearance between clutch lining and clutch plate. See Fig. 1, dimension B. Clearance must be between 1.0 - 1.5 mm. In case clearance is less than 1 mm or more than 1.5 mm contact AutoGyro customer support.
- 3 Measure clearance between inner (engine side) drive star disc and outer (clutch side) drive star claws. See Fig. 1, dimension C. Clearance must be between 1.0 - 1.5 mm. In case clearance is less than 1 mm or more than 1.5 mm contact AutoGyro customer support.

ILLUSTRATIONS

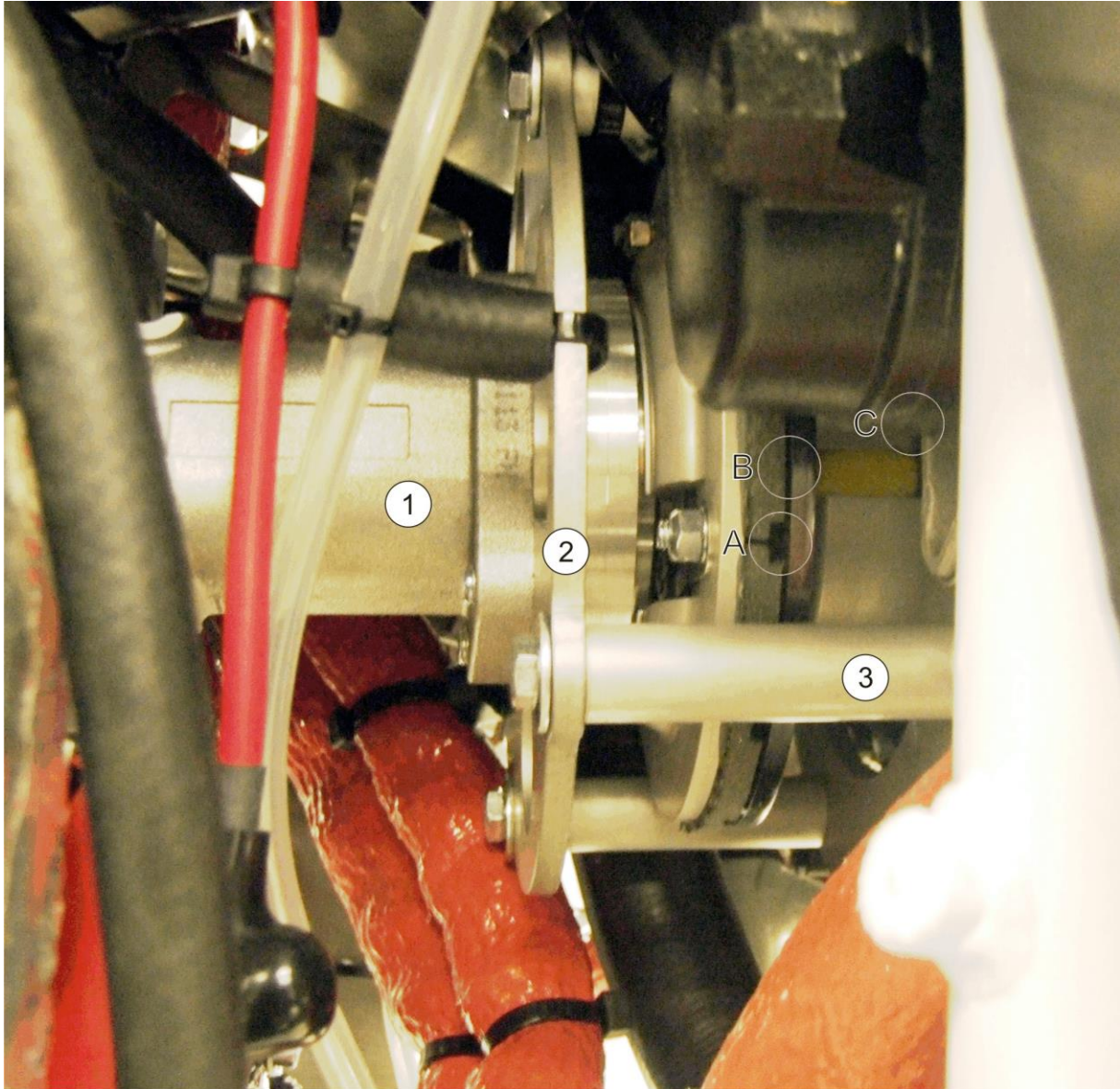

Fig. 1 - Pre-rotator clutch with attach ring

63-11-10 8-1 REPLACEMENT: PRE-ROTATOR CLUTCH LINING

HVY

GENERAL, REFERENCES AND REQUIREMENTS

Task may only be performed by an organization trained and entitled to carry out 'Heavy Maintenance'!

Secure gyroplane against unauthorized or unintended operation!

Engine cowlings must be removed, see [52-00-00 4-1](#)

SPECIAL TOOLS AND CONSUMABLE MATERIALS

88-00-00-S-35915 Loctite 7063 Super Clean

88-00-00-S-31023 Loctite 648

88-00-00-S-35790 Installation Aid Dog Gear

PRECAUTIONS AND SAFETY MEASURES

PROCEDURES

- 1 Disconnect battery according to [24-30-00 4-1](#), work steps 1 - 2.
- 2 Remove M8x20 screw plug (Fig. 2) with seal ring from the crankcase. Turn the crankshaft by propeller into top dead centre (TDC) position of cylinder 1 and 2. TDC can be checked with the aid of a lamp through the opening of the removed screw. When the crankshaft is in correct position screw thread pin M8x50 (Fig. 3) so that the crankshaft is blocked.
- 3 Remove pre-rotator clutch according to [63-11-10 4-1](#), work steps 1 - 9

IMPORTANT NOTE: New clutch liners feature an with improved design additional brake pad. Stock items having old design shall be returned to AutoGyro or discarded.
- 4 Replace clutch liner

In order to do so, untighten central screw. Should it not be possible untighten central screw bore out bolt head and remove remaining screw thread with pliers. Pull friction plate off the drive shaft axially. Place spare part and fix it with new central screw.
- 5 Remove clutch dog gear with 'Installation Aid Dog Gear'
- 6 Thoroughly clean the crankshaft and the driver stud with Loctite 7063

CAUTION: For the following work step, use Loctite 648 only! The use of other brands or alternative products will prevent correct functioning.
- 7 Apply Loctite 648 on inner and outer thread in sufficient quantity (Fig.4)

CAUTION: For the following work step, the clutch dog gear must be easily screwable (floating) up to the stop!
- 8 Screw dog clutch gear onto the thread and remove excess Loctite
- 9 Tighten dog clutch gear using 'Installation Aid Dog Gear' with a torque of 140 Nm (Fig. 5). Clean driver free of Loctite residues.
- 10 Check with feeler gauge 0.05 mm whether dog clutch gear is contacted with the flywheel. Feeler gauge 0.05 mm must not be able to stick in between dog clutch gear and flywheel (Fig. 6).
- 11 Remove thread pin M8x50. Mount M8x20 screw plug with new copper seal ring and tighten with a torque of 15 Nm. For checking, turn carefully the propeller by hand.
- 12 Re-connect battery according to [24-30-00 4-1](#), work steps 2 - 1.
- 13 Re-install pre-rotator clutch according to [63-11-10 4-1](#), work steps 10 - 19

PARTS LIST

Fig.	Pos.	Description	PC PIT	Remark
		Replacement set friction plate PK II / III	L1 61-00-00-S-33383	

ILLUSTRATIONS

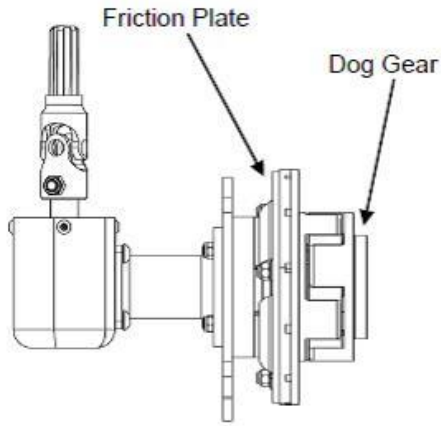

Fig. 1 - Pneumatic Clutch III

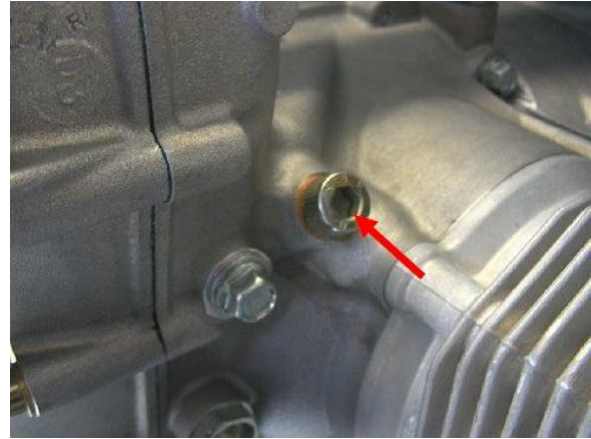

Fig. 2 - M8x20 screw plug



Fig. 3 - Thread Pin M8x50

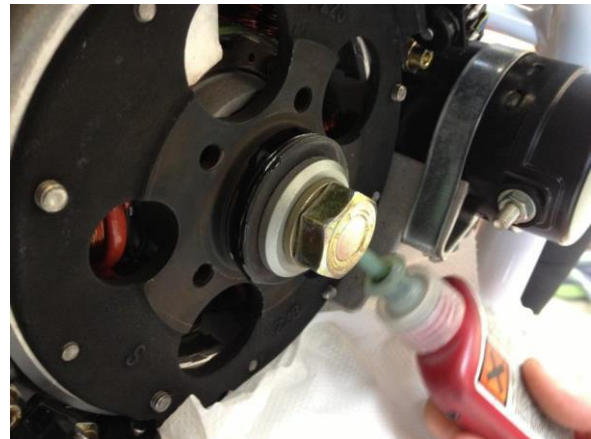

Fig. 4 - Loctite 648 on inner and outer thread



Fig. 5 - Torque dog gear with 140 Nm

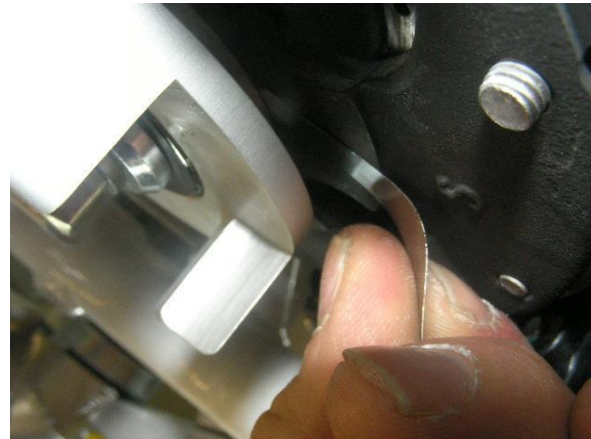

Fig. 6 - Correct mounting position

63-11-10 8-2 REPLACEMENT: PRE-ROTATOR CLUTCH DOG GEAR

HVY

GENERAL, REFERENCES AND REQUIREMENTS

Task may only be performed by an organization trained and entitled to carry out 'Heavy Maintenance'!

Secure gyroplane against unauthorized or unintended operation!

Engine cowlings must be removed, see [52-00-00 4-1](#)

SPECIAL TOOLS AND CONSUMABLE MATERIALS

88-00-00-S-35915 Loctite 7063 Super Clean

88-00-00-S-31023 Loctite 648

85-00-00-S-35790 Installation Aid Dog Gear

PRECAUTIONS AND SAFETY MEASURES

PROCEDURES

- 1 Disconnect battery according to [24-30-00 4-1](#), work steps 1 - 2.
- 2 Remove M8x20 screw plug (Fig. 1) with seal ring from the crankcase. Turn the crankshaft by propeller into top dead centre (TDC) position of cylinder 1 and 2. TDC can be checked with the aid of a lamp through the opening of the removed screw. When the crankshaft is in correct position screw in thread pin M8x50 (Fig. 2) so that the crankshaft is blocked (for further information see Rotax Maintenance Manual 12-20-00).
- 3 Remove pre-rotator clutch according to [63-11-10 4-1](#), work steps 1 - 9
- 4 Remove clutch dog gear with 'Installation Aid Dog Gear'
- 5 Thoroughly clean the crankshaft and the driver stud with Loctite 7063.
CAUTION: For the following work step, use Loctite 648 only! The use of other brands or alternative products will prevent correct functioning.
- 6 Apply Loctite 648 on inner and outer thread in sufficient quantity (Fig.4)
CAUTION: For the following work step, the clutch dog gear must be easily screwable (floating) up to the stop!
- 7 Screw dog clutch gear onto the thread and remove excess Loctite
- 8 Tighten dog clutch gear using 'Installation Aid Dog Gear' with a torque of 140 Nm (Fig. 5). Clean driver free of Loctite residues.
- 9 Check with feeler gauge 0.05 mm whether dog clutch gear is contacted with the flywheel. Feeler gauge 0.05 mm must not be able to stick in between dog clutch gear and flywheel (Fig. 6).
- 10 Remove thread pin M8x50. Install M8x20 screw plug with new copper seal ring and tighten with a torque of 15 Nm. For checking, carefully turn propeller by hand.
- 11 Re-connect battery according to [24-30-00 4-1](#), work steps 2 - 1
- 12 Re-install pre-rotator clutch according to [63-11-10 4-1](#), work steps 10 - 19.

PARTS LIST

Fig.	Pos.	Description	PC PIT	Remark
		pressure plate rear	L1 61-00-00-V-33792	

ILLUSTRATIONS

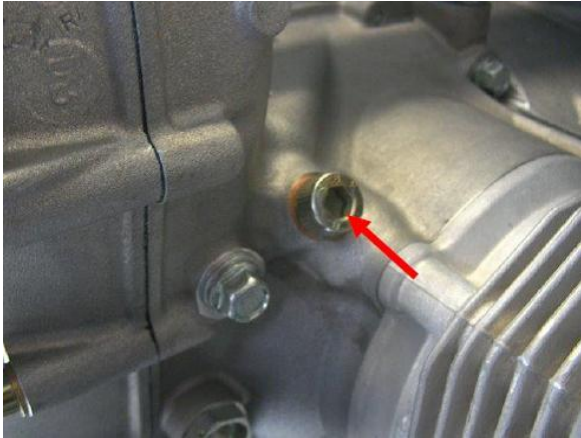

Fig. 1 - M8x20 screw plug



Fig. 2 - Thread Pin M8x50

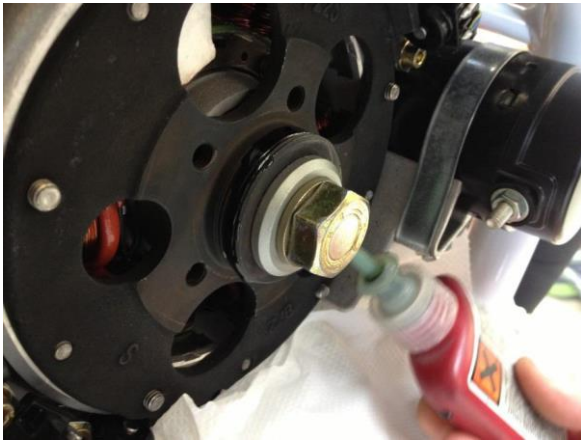

Fig. 3 - Loctite 648 on inner and outer thread

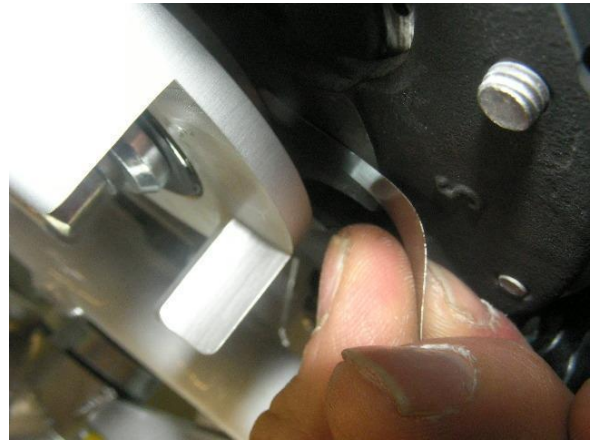

Fig. 4 - Correct mounting position

63-11-30 6-1 INSPECTION: PRE-ROTATOR UPPER ENGAGEMENT

LNE

GENERAL, REFERENCES AND REQUIREMENTS

Task may only be performed by an organization or individual trained and entitled to carry out 'Line Maintenance'!

Secure gyroplane against unauthorized or unintended operation!

Gyroplane must be placed on level ground and restrained (blocks, chocks)

Mast cover must be removed, see [52-00-00 4-1](#)

SPECIAL TOOLS AND CONSUMABLE MATERIALS

AG-GRS-01 Lagermeister WHS 2002 Grease (88-00-00-S-30477)

PRECAUTIONS AND SAFETY MEASURES

PROCEDURES

- 1 Inspect wear pattern and gear mesh of pre-rotator upper engagement. If in doubt, contact AutoGyro customer support.
- 2 If the wear pattern is uneven (see Fig. 1), e.g. due to dynamic skew, the pre-rotator upper engagement / Bendix shaft must be repaired acc. to [63-11-30 8-2](#).
IMPORTANT NOTE: adjustment job is classified as heavy maintenance (HVY)!
- 3 Inspect backlash of pre-rotator upper engagement. Backlash should be as tight as possible, but also wide enough to allow easy engagement of the pinion into the sprocket in any position.
- 4 If necessary, have backlash adjusted [62-31-00 5-1](#).
IMPORTANT NOTE: adjustment job is classified as heavy maintenance (HVY)!
- 5 Grease with AG-GRS-01.

ILLUSTRATIONS

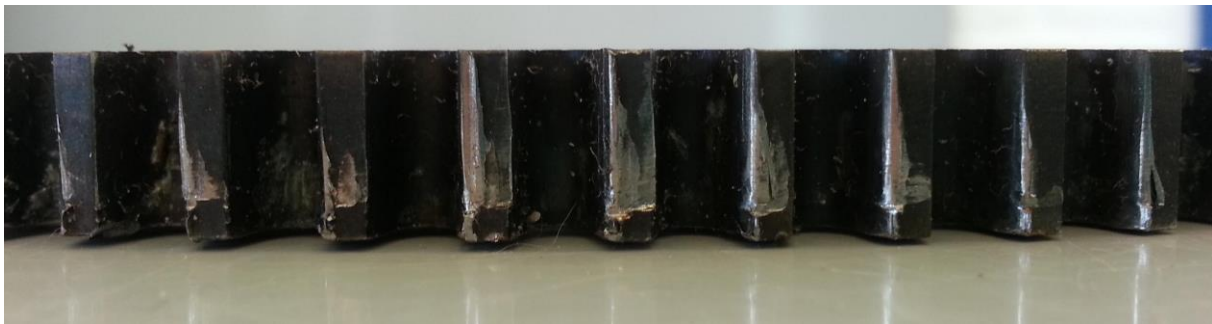

Fig. 1 - Wear Pattern (uneven)

63-11-30 8-1 REPLACEMENT: PRE-ROTATOR UPPER BEARINGS

HVY

GENERAL, REFERENCES AND REQUIREMENTS

Task may only be performed by an organization trained and entitled to carry out 'Heavy Maintenance'!
 Secure gyroplane against unauthorized or unintended operation!
 Gyroplane must be placed on level ground and restrained (blocks, chocks)
 Mast cover must be removed, see [52-00-00 4-1](#)

SPECIAL TOOLS AND CONSUMABLE MATERIALS

AG-BAS-02 Loctite 243 blue (88-00-00-S-30483)
 AG-BAS-05 Loctite 2701 green (88-00-00-S-30482)

PRECAUTIONS AND SAFETY MEASURES

PROCEDURES

- 1 Remove bolts (1/9) and washers (2/8).
- 2 Remove bracket (3/7) and replace bearing as required.
- 3 Apply a thin layer of AG-BAS-02 on threads of bolts (1/9), install bolts with serrated washers (2/8) and torque-tighten bolts.
- 4 Perform [63-11-30 6-1](#) "INSPECTION: PRE-ROTATOR UPPER ENGAGEMENT"

PARTS LIST

Fig.	Pos.	Description	PC PIT	Remark
1	1	Rivet 4x12 A2	NPI	
1	2	Bearing 6200 ZZNR	L2 27-30-00-V-20719	
1	3	Bracket pre rot top	NPI	
1	4	bendix	L2 27-30-00-V-20700	
1	5	M8x71 DIN 912 8x90	NPI	
1	6	U8	NPI	
1	7	M8 Si	NPI	
1	8	Bendix shaft helix	NPI	
1	9	Bendix shaft	NPI	
1	10	Bearing 6202 ZZNR	L2 27-30-00-V-20719	
1	11	Bracket pre rot bottom	NPI	
1	12	Safety washer M4	NPI	
1	13	M4x8	NPI	

ILLUSTRATIONS

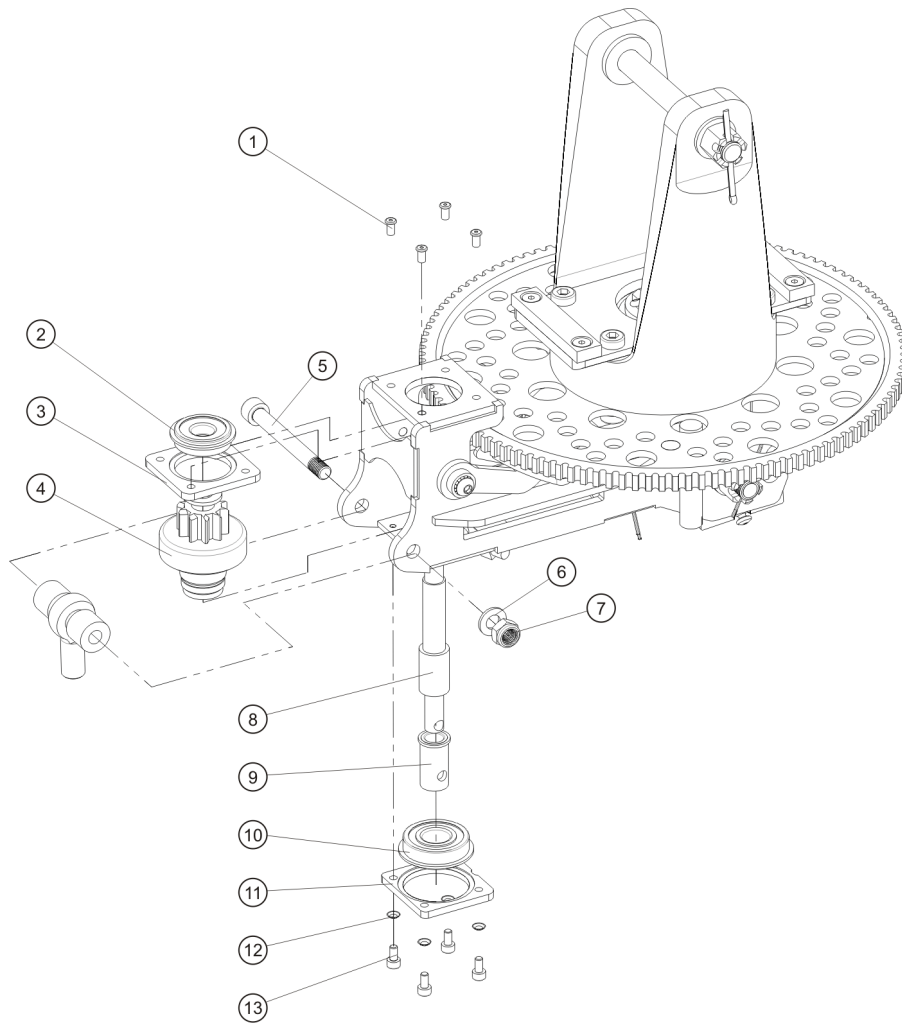

Fig. 1 - Prerotator upper bearing

63-11-30 8-2 REPAIR: PRE-ROTATOR UPPER ENGAGEMENT

HVY

GENERAL, REFERENCES AND REQUIREMENTS

Task may only be performed by an organization trained and entitled to carry out 'Heavy Maintenance'!

Secure gyroplane against unauthorized or unintended operation!

Gyroplane must be placed on level ground and restrained (blocks, chocks)

SPECIAL TOOLS AND CONSUMABLE MATERIALS

AG-BAS-04 Loctite 638 green (88-00-00-S-30485)

PRECAUTIONS AND SAFETY MEASURES

PROCEDURES

***NOTE: For removal, replacement or re-installation of bearings, refer to 63-11-30 8-1
"REPLACEMENT: PRE-ROTATOR UPPER BEARINGS"***

- 1 Remove lower bearing and ensure that the shaft is, in free load condition, centrally positioned in the bearing seating. If free play in the upper bearing is present, the following must be carried out:
- 2 **Free play due to bearing abrasion:** Replace upper bearing and glue Bendix shaft with Loctite 638 (high strength / AG-BAS-04) into the upper bearing. Re-assemble lower bearing.
- 3 **Free play due to abrasion of the Bendix shaft from ball bearing inner ring:** Glue Bendix shaft with Loctite 638 (high strength / AG-BAS-04) into upper bearing. Re-assemble lower bearing. If free play is greater than 1/10 mm, then replace Bendix shaft with new part and glue new part with Loctite 638 (high strength / AG-BAS-04) into upper bearing. Re-assemble lower bearing.
- 4 If in doubt or different cause of error suspected, contact AutoGyro customer support.
- 5 Grease with AG-GRS-01.

PARTS LIST

Fig. Pos. Description	PC PIT	Remark
Bearing 6200 ZZNR	L2 27-30-00-V-20719	
Bendix shaft long	L2 27-30-00-V-31801	

63-51-00 8-1 REPLACEMENT: ROTOR BRAKE PAD

LNE

GENERAL, REFERENCES AND REQUIREMENTS

Task may only be performed by an organization or individual trained and entitled to carry out 'Line Maintenance'!

Secure gyroplane against unauthorized or unintended operation!

Gyroplane must be placed on level ground and restrained (blocks, chocks)

Mast cover must be removed, see [52-00-00 4-1](#)

SPECIAL TOOLS AND CONSUMABLE MATERIALS

AG-BAS-02 Loctite 243 blue (88-00-00-S-30483)

SP **IMPORTANT NOTE:** Procedure involves spare parts. Check parts list below for ordering details of affected components!

PRECAUTIONS AND SAFETY MEASURES

IMPORTANT NOTE: Procedure involves handling and disposal of special materials. For your health and environmental aspects respect all applicable regulations!

PROCEDURES

NOTE: Brake pad can be replaced without disassembly of the rotor head.

- 1 Turn rotor so that bolts (1) can be accessed through the holes in the pre-rotator sprocket disc.
- 2 Unscrew bolts (1) and replace brake pad (2). Dispose of properly!
- 3 Install new brake pad.
- 4 Apply AG-BAS-02 on threads, install bolts (1) and tighten.

PARTS LIST

Fig.	Pos.	Description	PC PIT	Remark
1	1	M6x8 Countersunk	NPI	
1	2	Brake pad assembly	L1 27-30-00-V-31054	
1	3	brake pad ground plate	NPI	
1	4	M6 35/8	NPI	
1	6	Spacer 13-5,5/10-6/6	NPI	

ILLUSTRATIONS

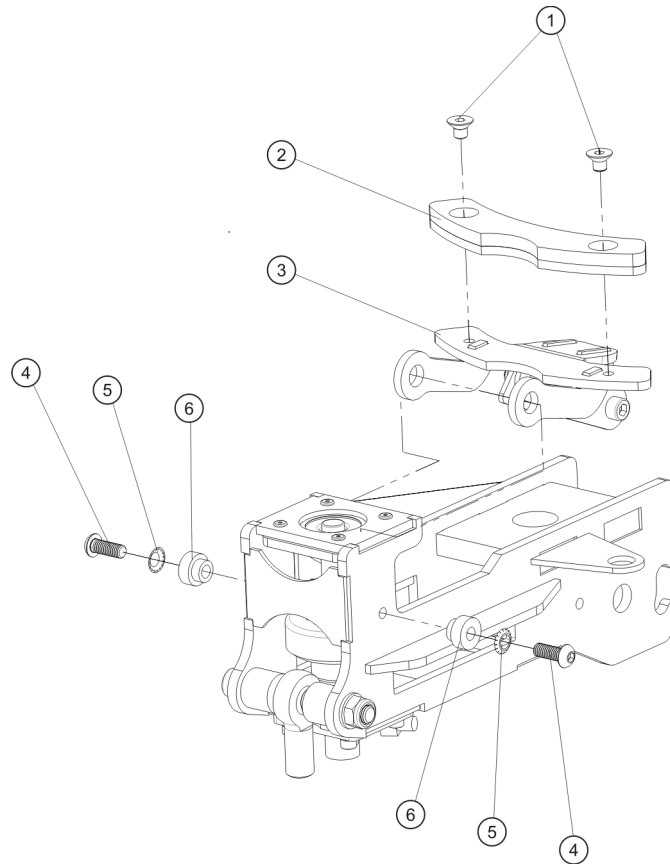

Fig. 1 - Rotor bridge with brake pad

67-00-00 6-1 INSPECTION: FLIGHT CONTROL PUSH-PULL CABLES

LNE

GENERAL, REFERENCES AND REQUIREMENTS

Task may only be performed by an organization or individual trained and entitled to carry out 'Line Maintenance'!

Secure gyroplane against unauthorized or unintended operation!

Mast cover must be removed, see [52-00-00 4-1](#)

SPECIAL TOOLS AND CONSUMABLE MATERIALS

None

PRECAUTIONS AND SAFETY MEASURES

PROCEDURES

- 1 Inspect upper attachment points of pitch and roll control push-pull cables. Check firm installation, colour seal intact. Check condition of rubber seal.
- 2 Inspect lower attachment point of pitch control push-pull cable. Check firm installation, colour seal intact.
- 3 Inspect lower attachment point of roll control push-pull cable. Check firm installation, colour seal intact.
- 4 Check free play of the pitch control push-pull cable. In order to do so, modify the rotor head stop using the shaft of a drill or similar (see Fig. 1) and apply a minimum of 8 bar of brake pressure. Measure free play / dead travel of flight control stick as depicted in Fig. 1.
- 5 Check free play of the roll control push-pull cable. Measure lateral free play / dead travel of flight control stick against the natural friction of the gimbal head.
- 6 If free play in any control axis exceeds 8 mm at control stick head contact AutoGyro customer support.

ILLUSTRATIONS



Fig. 1 - Pitch and Roll - upper attachment

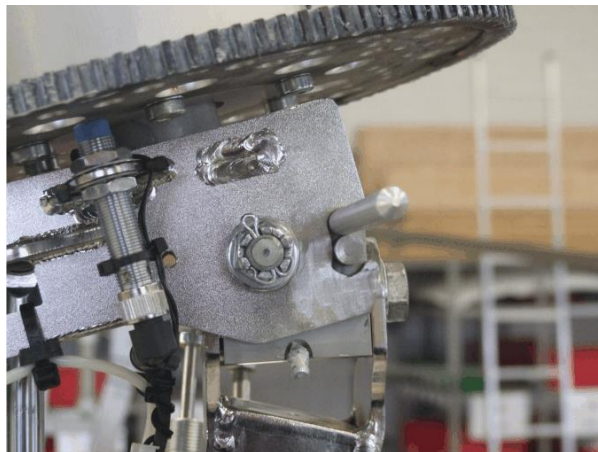

Fig. 2 - Modification of rotor head stop



Fig. 3 - Measurement of freeplay

67-00-00 8-1 RETROFIT: PPC CLAMPS

HVY

GENERAL, REFERENCES AND REQUIREMENTS

Task may only be performed by an organization trained and entitled to carry out 'Heavy Maintenance'!

Secure gyroplane against unauthorized or unintended operation!

Rotor system must be removed, see [62-11-00 4-1](#)

SPECIAL TOOLS AND CONSUMABLE MATERIALS

88-00-00-S-33587 Screw Securing and Thread-Sealing Varnish yellow

PRECAUTIONS AND SAFETY MEASURES

WARNING: Job includes work at critical flight controls. Duplicate inspection must be performed after completion!

CAUTION: Braided steel lines are highly abrasive!

CAUTION: Failure to comply with this instruction will cause the loss of warranty referred and/or related components.

PROCEDURES

- 1 Open service access cover to reach middle radius of the push-pull control cables.
- 2 If necessary push aside disturbing lines and remove relevant cable ties.
- 3 Attach the PPC clamps to the PPC Pitch and PPC Roll in the middle radius of push-pull control cables. Insert two M5 bolts and two serrated washers and torque-tighten bolts with 1.5 Nm (Fig.1).
- 4 Check the roll and nick control with the stick and make sure a constant is resistance is noticeable.
- 5 If you notice resistance peaks (chattering) in flight control, untighten the respective PPC clamp(s) and torque-tighten with 1.0 Nm again. Increase the torque value of PPC clamps in 0.1 Nm steps until there are resistance peaks in flight control noticeable. Finally, decrease the torque value of PPC clamps in 0.1Nm steps until there is constant resistance in the stick noticeable
- 6 Check the push-pull control cables according to [67-00-00 6-2](#).
- 7 Secure bolts of PPC clamps with securing paint.
- 8 Reposition pushed-aside lines from step 2 into original position and fix with cable ties.
- 9 Close the access service cover.

PARTS LIST

Fig.	Pos.	Description	PC PIT	Remark
		PPC clamp	27-30-00-V-37944	

ILLUSTRATIONS

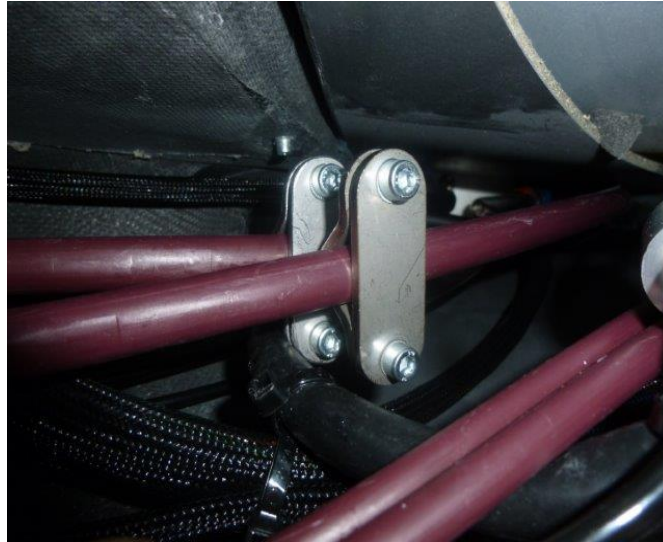

PPC Clamps

67-05-00 8-1 REPLACEMENT: PITCH TRIM/BRAKE PNEUMATIC SEAL

HVY

GENERAL, REFERENCES AND REQUIREMENTS

Task may only be performed by an organization trained and entitled to carry out 'Heavy Maintenance'!

Secure gyroplane against unauthorized or unintended operation!

Mast cover must be removed, see [52-00-00 4-1](#)

SPECIAL TOOLS AND CONSUMABLE MATERIALS

AG-BAS-02 Loctite 243 blue (88-00-00-S-30483)

SP **IMPORTANT NOTE:** Procedure involves spare parts. Check parts list below for ordering details of affected components!

PRECAUTIONS AND SAFETY MEASURES

PROCEDURES

- 1 Install rotor lash bag to support rotor system.
- 2 Switch pneumatic mode selector to FLIGHT and release trim pressure completely. If necessary, switch repeatedly!
- 3 Disconnect ball joint (rod end) from rotor brake bracket (ground plate).
- 4 Retract cylinder (pneumatic mode selector to FLIGHT and trim aft) and remove ball head from rod end.
- 5 Remove circlip / snap ring with appropriate tool.
- 6 Tilt pneumatic cylinder aft and pull out piston completely. In order to do so, switch pneumatic mode selector to BRAKE and apply brake pressure.

NOTE: The servo-valve requires a certain system pressure to switch-over to BRAKE mode. If brake pressure is not built-up during compressor activation, switch to FLIGHT, run the compressor (trim AFT) for some seconds and switch-over to BRAKE mode with the compressor engaged.

- 7 Remove old seal ring and discard. Install new seal ring using the special grease provided in the package.
- 8 Re-install piston and re-assemble pneumatic cylinder. Re-install circlip / snap ring.
- 9 Apply AG-BAS-02 on threads, install ball head and tighten.
- 10 Re-connect ball joint with rotor brake bracket (ground plate).

PARTS LIST

Fig.	Pos.	Description	PC PIT	Remark
		Pneumatic cylinder brake/trim repair kit	L1 27-30-00-S-32926	

67-10-00 4-1 REMOVAL-INSTALLATION: CENTRE CONSOLE

LNE

GENERAL, REFERENCES AND REQUIREMENTS

Task may only be performed by an organization or individual trained and entitled to carry out 'Line Maintenance'!
Secure gyroplane against unauthorized or unintended operation!

SPECIAL TOOLS AND CONSUMABLE MATERIALS

None

PRECAUTIONS AND SAFETY MEASURES

PROCEDURES

Removal

- 1 Untighten the 3 central bolts by about 5 revolutions.
- 2 Unscrew and remove the 10 circumference bolts.
EFFECTIVITY: Cabin heating installed
- 3 Remove dummy plug and unscrew bolt in order to detach heating control lever from heating control valve (use a 2.5 mm round head Allen key).
- 4 Apply tape at the surrounding areas as surface protection.
- 5 Pull console aft and slip-out brake fluid reservoir (front).

Installation

- 6 Re-install in reverse order (work steps 5 to 1)

***NOTE: The heating control lever is connected to the valve by a force-type connection.
Ensure correct installation and operation!***

ILLUSTRATIONS

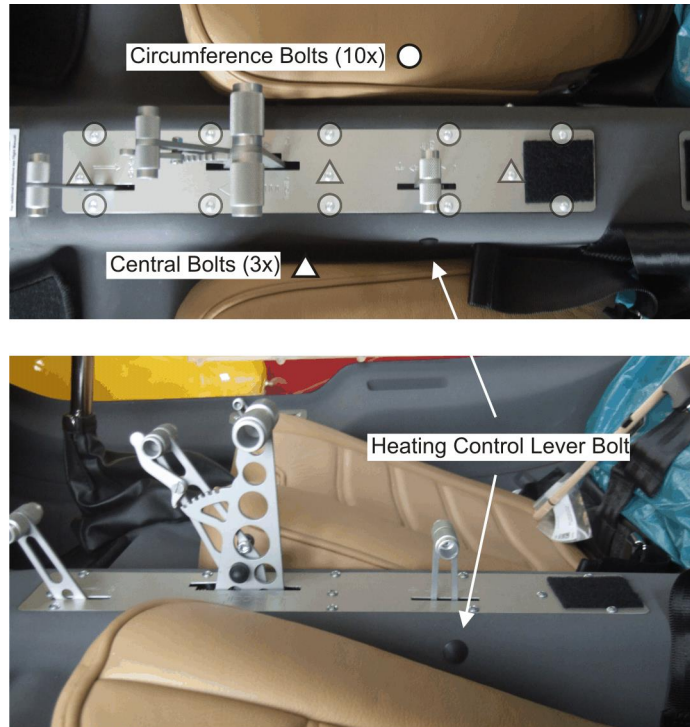

Fig. 1 - Centre Console

71-20-00 6-1 INSPECTION: CLEARANCE ENGINE INSTALLATION (R914) LNE

GENERAL, REFERENCES AND REQUIREMENTS

Task may only be performed by an organization or individual trained and entitled to carry out 'Line Maintenance'!

Engine cowlings must be removed, see [52-00-00 4-1](#)

SPECIAL TOOLS AND CONSUMABLE MATERIALS

None

PRECAUTIONS AND SAFETY MEASURES

PROCEDURES

NOTE: A clearance of less than 3 mm between airbox and engine support and/or wear marks may indicate worn-out engine mounting bushings. If the following work steps do not corrects the situation the engine mounting bushings must be replaced [71-20-00 8-1](#).

- 1 Untighten the connection couplings (see markings in Fig. 1).
- 2 Adjust clearance of at least 5 mm.
- 3 Tighten the connection couplings.

ILLUSTRATIONS



Fig. 1 - Clearance airbox to engine mounting frame (R914)

71-30-00 4-1 REMOVAL-INSTALLATION: FIRE WALL

LNE

GENERAL, REFERENCES AND REQUIREMENTS

Task may only be performed by an organization or individual trained and entitled to carry out 'Line Maintenance'!
Engine cowlings must be removed, see [52-00-00 4-1](#)

SPECIAL TOOLS AND CONSUMABLE MATERIALS

None

PRECAUTIONS AND SAFETY MEASURES

PROCEDURES

Removal

NOTE: The removable part actually consists of two parts joint by connecting bolts which, in most cases, do not need to be separated at removal or installation.

- 1 Remove air intake box.
- 2 Remove 24 x attachment bolt with plastic washer.
- 3 Carefully pull out fire wall - removable part(s).

Installation

- 5 Install fire wall in reverse order (work steps 3 to 1) using moderate torque.

ILLUSTRATIONS

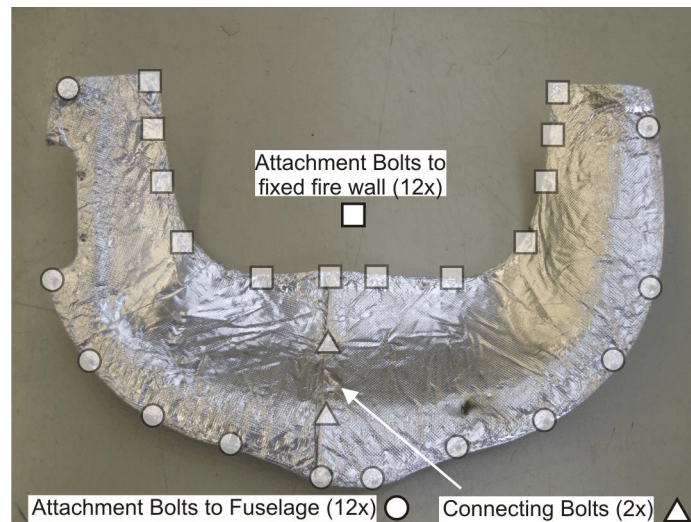

Fig. 1 - Fire Wall - removable part(s)

75-00-00 4-1 REMOVAL-INSTALLATION:RADIATOR

HVY

GENERAL, REFERENCES AND REQUIREMENTS

Task may only be performed by an organization trained and entitled to carry out 'Heavy Maintenance'!

Secure gyroplane against unauthorized or unintended operation!

Engine cowlings must be removed, see [52-00-00 4-1](#)

Execute procedure only in cold engine condition!

SPECIAL TOOLS AND CONSUMABLE MATERIALS

AG-CPA-02 Radiator coolant BASF G48 Protect Plus (71-70-00-V-30163)

CMM Refer to the component/device manufacturer's documentation.

PRECAUTIONS AND SAFETY MEASURES

PROCEDURES

Removal

- 1 Disconnect coolant outlet on cylinder 1, open expansion tank and drain coolant
- 2 Unscrew radiator brackets (left and right hand side) from propeller gearbox
- 3 Disconnect electronic connectors for radiator fan
- 4 Disconnect coolant hose between expansion tank and radiator from the radiator
- 5 Unscrew the two forward radiator attachment points
- 6 Disconnect radiator inlet and outlet hoses from radiator
- 7 Remove radiator from the engine
- 8 Remove radiator brackets (left and right hand side / see step 2) from radiator

Installation

- 9 For installation execute removal in reverse order
- 10 For coolant mixture and filling quantity refer to [12-40-00](#) and engine manufacturers manual.

75-00-00 8-2 MODIFICATION: RECONFIGURE FAN REVERSE

LNE

GENERAL, REFERENCES AND REQUIREMENTS

Task may only be performed by an organization or individual trained and entitled to carry out 'Line Maintenance'!

Secure gyroplane against unauthorized or unintended operation!

Engine cowlings must be removed, see [52-00-00 4-1](#)

Fire wall must be removed, see [71-30-00 4-1](#)

SPECIAL TOOLS AND CONSUMABLE MATERIALS

None

PRECAUTIONS AND SAFETY MEASURES

WARNING: Electrical shorting of the battery will produce high current with the risk of personal injury and damage to equipment!

PROCEDURES

- 1 Disconnect battery according to [24-30-00 4-1](#), work steps 1 - 2.
- 2 Detach fan reverse control unit (Fig. 1) from rear wall, cut fan reverse cable (Fig. 2) and remove fan reverse control unit.
- 3 Isolate red wire 0,5 mm² and black wire 0,5 mm² with shrinking hoses and remove insulation of all 1,5 mm² wires (Fig. 2).
- 4 Crimp isolated butt connectors to wires and connect red/red and black/black (Fig. 3). Make sure connectors are properly isolated to avoid shortcut.
- 5 Secure cable and connectors with cable ties according to Fig. 4.
- 6 Re-connect battery according to [24-30-00 4-1](#), work steps 2 - 1.
- 7 Perform functional check.

PARTS LIST

Fig.	Pos.	Description	PC PIT	Remark
		Replacement set Mast Attachment	L2 27-30-00-S-35972	

ILLUSTRATIONS



Fig. 1 - Fan reverse control unit

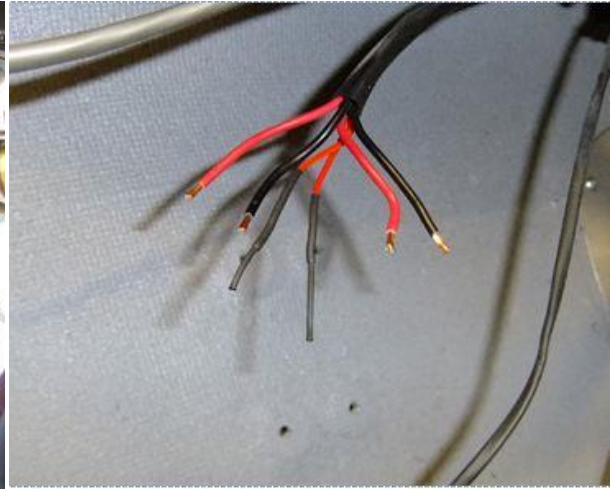

Fig. 2 - Fan reverse cable - detached

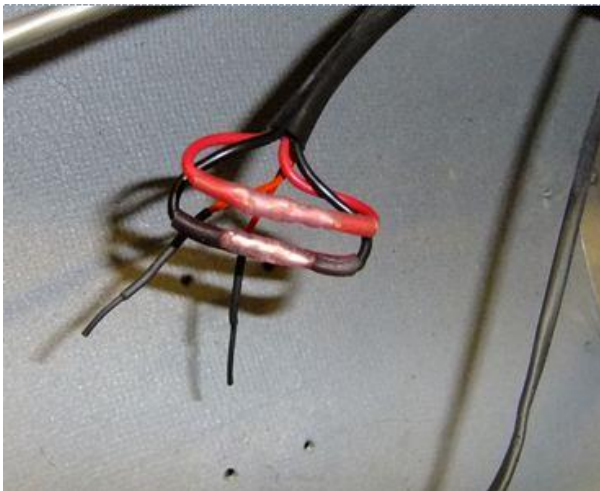

Fig. 3 - Fan reverse cable - modified

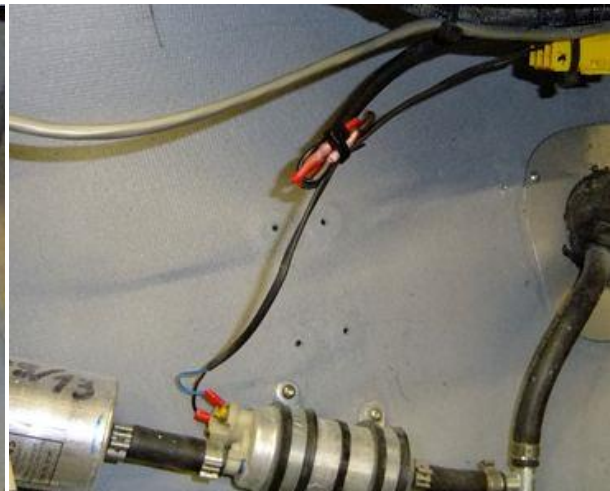

Fig. 4 - Fan reverse cable - secured

78-20-00 8-1 REPLACEMENT: WOOL OF MUFFLER TUBE

LNE

GENERAL, REFERENCES AND REQUIREMENTS

Task may only be performed by an organization or individual trained and entitled to carry out 'Line Maintenance'!

Secure gyroplane against unauthorized or unintended operation!

Execute procedure only in cold engine condition!

Engine cowlings must be removed, see [52-00-00 4-1!](#)

SPECIAL TOOLS AND CONSUMABLE MATERIALS

- | | |
|----|---|
| LR | IMPORTANT NOTE: Procedure involves parts with limited reusability. Check parts list below before starting job! |
| SP | IMPORTANT NOTE: Procedure involves spare parts. Check parts list below for ordering details of affected components! |

PRECAUTIONS AND SAFETY MEASURES

WARNING: Risk of severe burns and scalds! Hot engine parts! Always allow engine to cool down to ambient temperature before start any work!

WARNING: Wear eye protection and mind FOD when removing attachment hardware!

CAUTION: When removing or disassembling make sure to mark all parts so that each and every part of the component is re-assembled and installed in exactly the same location and orientation!

PROCEDURES

Removal

- 1 Remove and dispose the locking wire of the hose clamps.
- 2 Loosen the hinge pin clamp (Fig.1).
- 3 Before replacing the muffler tube, mark the position so that the muffler tube can be exactly installed in the same location and orientation.
- 4 Remove the hose clamps and keep them for the installation procedure (Fig.2). Inspect the hose clamps for possible damage.
- 5 Remove and clamp muffler tube in bench vise carefully.
- 6 Use appropriate tools to drive out the riveting mandrels.
- 7 Drill out the rivet pin (Fig.3). Then, use appropriate tool to tap out the pin of the rivet
- 9 Remove the rivet mandrel and rivet heads from the wool if it is left in place. Make sure any metal swarf is removed.
- 10 Check the wool. If it is visibly burnt, remove it completely.
- 11 Install the whole new wool with tension tightly around the pipe (Fig.4).

Installation

Important: Rivet the outer shell to the hot end of the muffler tube.

Effectivity: When the outer shell is riveted to the cold end (Fig.5).

- 12 When the outer shell is riveted to the cold end, reposition the outer shell so that the outer shell can be riveted to the hot end (Abb.1).
- 13 Install the outer shell and mark the position of the four rivet holes.
- 14 Remove the outer shell and drill four holes. Make sure any metal swarf is removed.

Effectivity: END

- 15 Install the outer shell. Make sure that the rivets holes of muffler tube and the steel tube are perfectly lined up (Fig.6).
- 16 Insert the four rivets into the hole and install them with a rivet gun (Fig.6).
- 17 Set and fix the muffler tube into the correct position with hose clamps and hinge pin clamp, so that the muffler tube remains adjustable (Fig.7).
- 18 Fix the bottom cowling according to chapter 52-00-00 4-1. Make sure that the pipe of muffler tube is placed in the middle opening (surrounding 15 mm). If necessary, adjust the position of the muffler tube (Fig.8).
- 19 Remove the bottom cowling and tighten the two hose clamps and hinge pin clamp.
- 20 Secure the screws of hose clamps with locking wire (Fig.9).
- 21 Install the cowling according to chapter [52-00-00 4-1](#) .

PARTS LIST

Fig.	Pos.	Description	PC PIT	Remark
		Replacement kit wool aftersilencer	L1 78-20-00-S-33478	
		Conversion Kit overflow muffler shell	L1 78-20-00-S-42441	

ILLUSTRATIONS

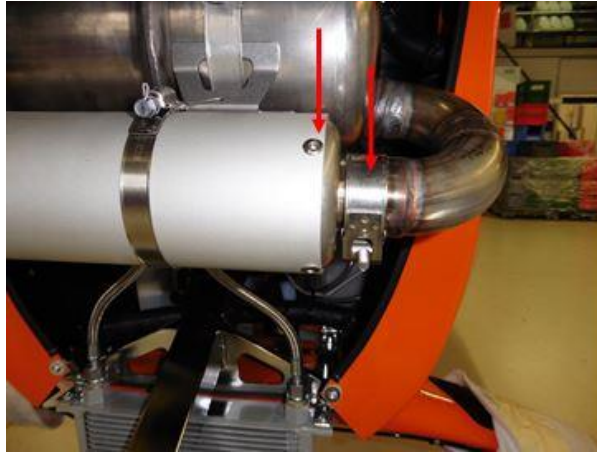

Fig 1 - Rivets at the hot and hinge pin clamp

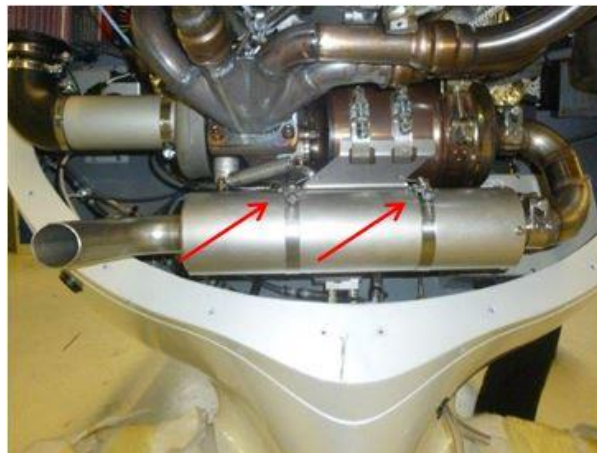

Fig. 2 - Hose clamps



Fig. 3 - Drill out the rivet pin



Fig. 4 - Installation of absorption wool



Fig. 5 - Rivets at the cold end of muffler tube



Fig. 6 - Riveting of the outer shell

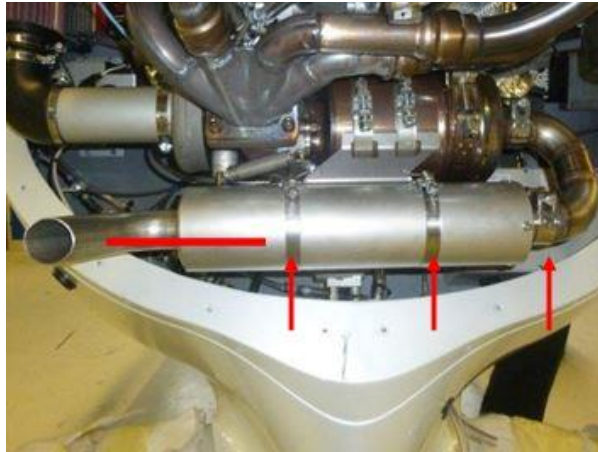

Fig. 7 - Installation of hose clamps and hinge pin clamp



Fig. 8 - Position of the muffler tube

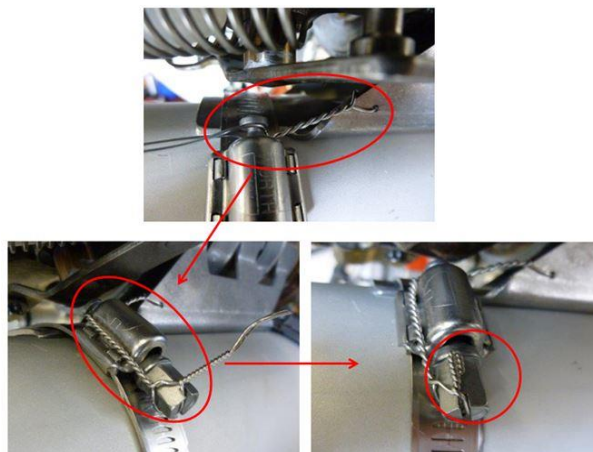

Fig. 9 - Installation of locking wire



www.auto-gyro.com

AutoGyro GmbH
Dornierstrasse 14
31137 Hildesheim
Germany

Phone +49 (0) 5121 / 880 56-00
info@auto-gyro.com
www.auto-gyro.com