

Title: Pneumatic Clutch III (2017) – Pressure Disc Inspection		
AG-SB-2018-05-B-EN		Compliance Category:
Applicability		A – MANDATORY
Aircraft type & model: All MTO2017 and all Calidus/Cavalon with rotor head III fitted	Affected Serial number(s): All MTO2017 and all Calidus/Cavalon with rotor head III fitted	B – RECOMMENDED
The maintenance manual to be referenced is this stated or subsequent issue.		C – OPTIONAL
As per AutoGyro website		
<p>This form is the response from AutoGyro GmbH either against a problem found in the product in service requiring a containment or rectification action, or as service information for aircraft modification incorporation. For help, contact AutoGyro on 49(0)5121 88056-00, or email airworthiness@auto-gyro.com.</p>		

Documentation (Service Bulletin Completion action)

The accomplishment of this Service Bulletin, or the decision of its rejection, must be properly documented, if such procedure is required by the relevant authority

Category Codes

A – Mandatory – failure to comply result in a significant reduction of flight safety, injury or death
 B – Recommended – failure to comply may result in reduced safety margin, injury and/or equipment damage
 C - Optional – improves operating behavior, reliability and/or maintainability

<p>Chief Certification Officer</p>  <p>G. Speich Sep 26 2018 6:39 AM</p> <p><small>This document has been issued according to an approved computer generated signature procedure</small></p> 	<p>Chief Technical Officer</p>  <p>Otmar Birkner Sep 26 2018 9:33 AM</p> 
--	---

<p>Contact & Info: airworthiness@auto-gyro.com www.auto-gyro.com</p>	<p>AutoGyro GmbH Dornierstr. 14 31137 Hildesheim</p>
---	---

Reason and overview of the Service Bulletin (cause of problem if known)

It has been found that the threaded holes in the first batch of pneumatic clutch III (2017) Pressure Plate front (2) are not sufficiently countersunk to accept the countersunk screws securing the Pressure Disc PKII (1). The effect is that the screws are unable to properly clamp the disc and plate together, possibly leading to looseness, rattle noise, and wear of this connection.

This bulletin issues instructions for the inspection of the clutch, countersinking of the threaded holes, and replacement of any damaged parts as required.

Manpower estimates

The task may only be performed by an organization or individual entitled and trained to do.

Estimated man-hours to complete the task as a stand-alone item is:

approx. 4 to 8hours depending on the installation and documentation requirements.

Tooling required

45° countersink tool may be required.

Weight and Balance Effects

No significant effect

Manuals affected

POH AutoGyro and AMM AutoGyro are not affected.

Previous Modifications that affect the SB

None

Accomplishment instructions (Action required to implement this bulletin):

Effective date of this SB is 30th August 2018

Instructions

1. Remove any cowlings required to gain access to the clutch assembly.
2. Remove the pneumatic clutch from the engine in accordance with AMM job card 63-11-10 4-1.
3. Remove the center screw retaining the pressure plate assembly (31713) to the clutch in accordance with AMM job card 63-11-10 8-1 part 4.
4. Remove the pressure plate assembly (31713) from the clutch and remove the 4 countersunk screws (3) securing the pressure disc (1) to the pressure plate front (2).
5. Inspect for signs of rotational movement of the pressure disc (1) on the pressure plate front (2), and/or elongated holes in the disc (1). If damaged, replace (article 23604).
6. Inspect the complete clutch assembly for any further damage and replace any affected parts (eg. 31713 Pressure Plate Mounted).
7. Inspect the pressure plate front (2) and ensure that the threaded holes (4) are countersunk to a

- depth of 1mm with a 45° countersink. If not, re-work with a suitable countersink tool.
8. Re-assemble the clutch in reverse order of disassembly.
 9. Assemble the clutch to the engine in accordance with AMM job card 63-11-10 4-1.
 10. Re-fit any cowlings previously removed.
 11. Ground run the aircraft in a suitably secured area, including a pre-rotation clutch functional check.
 12. Note the SB action within the aircraft documentation.

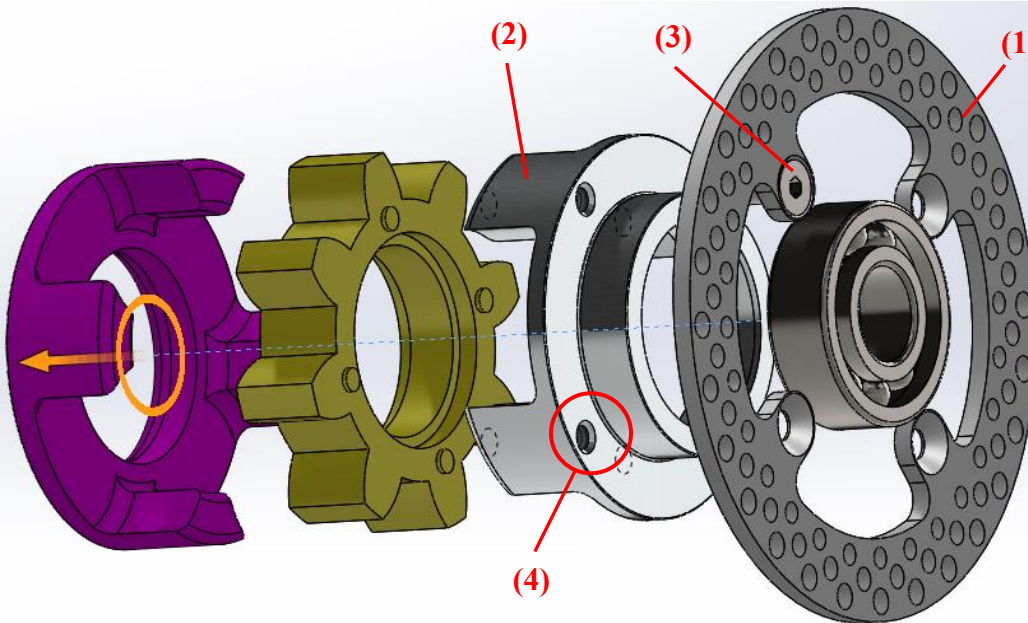

Fig. 1 - Pressure Plate Assembly (31713)

Completion of this Service Bulletin must be recorded

Material information (Parts required to be made to implement this service bulletin):

23604 Pressure Disc PKII (if required)
 31713 Pressure Plate Mounted (if required)
 23612 M5x25 M5x25, Allen-countersunk (if required)

List of components (with purchasable part nos)

Consumables used: Loctite Blue 243 (30483)

Interchangeability

Not affected

Parts disposition

- a) Disposal requirements – Normal waste
- b) Environmental hazards of parts containing hazardous materials - None
- c) Scrap requirements (e.g. mutilate scrapped items beyond use) – Not applicable

